



U.S. Department
of Transportation
**Federal Highway
Administration**

November 29, 2006

400 Seventh St., S.W.
Washington, D.C. 20590

In Reply Refer To:
HSA-10/SS-143

Ms. Shubha Hosalli
Quality Assurance Test Specialist
Carmanah Technologies Corp.
Building 300, 700 Enterprise Crs.
Victoria, BC V8Z 6R4
Canada

Dear Ms. Hosalli

Thank you for your letter of August 14, 2006, requesting the Federal Highway Administration's (FHWA) acceptance of your company's "i-Stop®" solar-powered transit stop assembly as a breakaway sign support system for use on the National Highway System (NHS). Accompanying your letter were drawings of the "i-Stop®" system, and information on the Xcessories Squared "Kleen Break" coupler breakaway mechanism. You requested that we find the signage system incorporating the "i-Stop®" and the "Kleen Break" acceptable for use on the NHS under the provisions of the National Cooperative Highway Research Program (NCHRP) Report 350 "Recommended Procedures for the Safety Performance Evaluation of Highway Features."

Introduction

Testing of the Kleen Break was in compliance with the guidelines contained in the NCHRP Report 350, Recommended Procedures for the Safety Performance Evaluation of Highway Features and was documented in the FHWA acceptance letter SS-131 dated December 2, 2005. Requirements for breakaway supports are those in the American Association of State Highway and Transportation Officials' Standard Specifications for Structural Supports for Highway Signs, Luminaires and Traffic Signals.

The "i-Stop®" solar-powered LED transit stop assembly is a self-contained unit that includes a flashing bus signaling device, a security down light, and an illuminated schedule. Also typically included are one or more street name signs, bus stop identifying "flag," and a bus schedule assembly that includes buttons to activate the light/illumination systems. These assemblies are securely mounted to steel sign posts that utilize the Xcessories Squared "Kleen Break" breakaway coupling device. An illustration of the overall "i-Stop®" installation is attached for reference.

Findings

Because the weight of the various components of the "i-Stop®" system weigh less than 50 pounds and are securely affixed to steel poles mounted on crashworthy breakaway supports, the devices described above and shown in the enclosed illustrations for reference are acceptable for use as test level 3 devices on the NHS under the range of conditions tested, when proposed by a State.



Please note the following standard provisions that apply to the FHWA letters of acceptance:

- Our acceptance is limited to the crashworthiness characteristics of the devices and does not cover their structural features, or conformity with the Manual on Uniform Traffic Control Devices.
- Any changes that may adversely influence the crashworthiness of the device will require a new acceptance letter.
- Should the FHWA discover that the qualification testing was flawed, that in-service performance reveals unacceptable safety problems, or that the device being marketed is significantly different from the version that was crash tested, it reserves the right to modify or revoke its acceptance.
- You will be expected to supply potential users with sufficient information on design and installation requirements to ensure proper performance.
- You will be expected to certify to potential users that the hardware furnished has essentially the same chemistry, mechanical properties, and geometry as that submitted for acceptance, and that they will meet the crashworthiness requirements of the FHWA and the NCHRP Report 350.
- To prevent misunderstanding by others, this letter of acceptance, designated as number SS-143, shall not be reproduced except in full. As this letter and the supporting documentation which support it become public information, it will be available for inspection at our office by interested parties.
- The “i-Stop®” and “Kleen Break” systems are patented devices and considered "proprietary." When proprietary devices are *specified by a highway agency* for use on Federal-aid projects: (a) they must be supplied through competitive bidding with equally suitable unpatented items; (b) the highway agency must certify that they are essential for synchronization with existing highway facilities or that no equally suitable alternative exists; (c) they must be used for research or for a distinctive type of construction on relatively short sections of road for experimental purposes. Our regulations concerning proprietary products are contained in Title 23, Code of Federal Regulations, Section 635.411, a copy of which is enclosed.
- This acceptance letter shall not be construed as authorization or consent by the FHWA to use, manufacture, or sell any patented device for which the applicant is not the patent holder. The acceptance letter is limited to the crashworthiness characteristics of the candidate device, and the FHWA is neither prepared nor required to become involved in issues concerning patent law. Patent issues, if any, are to be resolved by the applicant.

Sincerely yours,

/original signed by/

John R. Baxter, P.E.
Director, Office of Safety Design
Office of Safety

Enclosures

FHWA:HSA-10:MLupes:tb:x66994:11/29/06

File: s://directory folder/mlupes/SS-143-Accept_Ltr.doc

cc: HSA-10 (Reader, HSA-1; Chron File, HSA-10; M.Lupes, HSA-10;
M.McDonough, HSA-10)

Title 23, Code of Federal Regulations, Section 635.411

(a) Federal funds shall not participate, directly or indirectly, in payment for any premium or royalty on any patented or proprietary material, specification, or process specifically set forth in the plans and specifications for a project, unless:

(1) Such patented or proprietary item is purchased or obtained through competitive bidding with equally suitable unpatented items; or

(2) The State transportation department certifies either that such patented or proprietary item is essential for synchronization with existing highway facilities, or that no equally suitable alternate exists; or

(3) Such patented or proprietary item is used for research or for a distinctive type of construction on relatively short sections of road for experimental purposes.

(b) When there is available for purchase more than one nonpatented, nonproprietary material, semifinished or finished article or product that will fulfill the requirements for an item of work of a project and these available materials or products are judged to be of satisfactory quality and equally acceptable on the basis of engineering analysis and the anticipated prices for the related item(s) of work are estimated to be approximately the same, the PS&E for the project shall either contain or include by reference the specifications for each such material or product that is considered acceptable for incorporation in the work. If the State transportation department wishes to substitute some other acceptable material or product for the material or product designated by the successful bidder or bid as the lowest alternate, and such substitution results in an increase in costs, there will not be Federal-aid participation in any increase in costs.

(c) A State transportation department may require a specific material or product when there are other acceptable materials and products, when such specific choice is approved by the Division Administrator as being in the public interest. When the Division Administrator's approval is not obtained, the item will be nonparticipating unless bidding procedures are used that establish the unit price of each acceptable alternative. In this case Federal-aid participation will be based on the lowest price so established.

(d) Appendix A sets forth the FHWA requirements regarding (1) the specification of alternative types of culvert pipes, and (2) the number and types of such alternatives which must be set forth in the specifications for various types of drainage installations.

(e) Reference in specifications and on plans to single trade name materials will not be approved on Federal-aid contracts.

(f) In the case of a design-build project, the following requirements apply: Federal funds shall not participate, directly or indirectly, in payment for any premium or royalty on any patented or proprietary material, specification, or process specifically set forth in the Request for Proposals document unless the conditions of paragraph (a) of this section are applicable.



Carmanah®

Sign Post - Dimensions for i-STOP Assembly

Solid Steel square post	gauge	Thickness	Height of the steel post	Minimum Sectional modulus	Maximum Sectional Modulus
1.75"	14ga	1.9mm	127"	0.248 cubic inch	0.710 Cubic inch
1.75"	12ga	1.6mm	127"	0.248 cubic inch	0.710 Cubic inch
2"	14ga	1.9mm	127"	0.248 cubic inch	0.710 Cubic inch
2"	12ga	1.6mm	127"	0.248 cubic inch	0.710 Cubic inch

REVISION			
REV.	DESCRIPTION	DATE	APPROVED
X1	INITIAL RELEASE FOR FHWA DOCUMENTATION REQUEST	11/5/2006	T HARMON

THREE FEATURE i-STOP OVERVIEW:

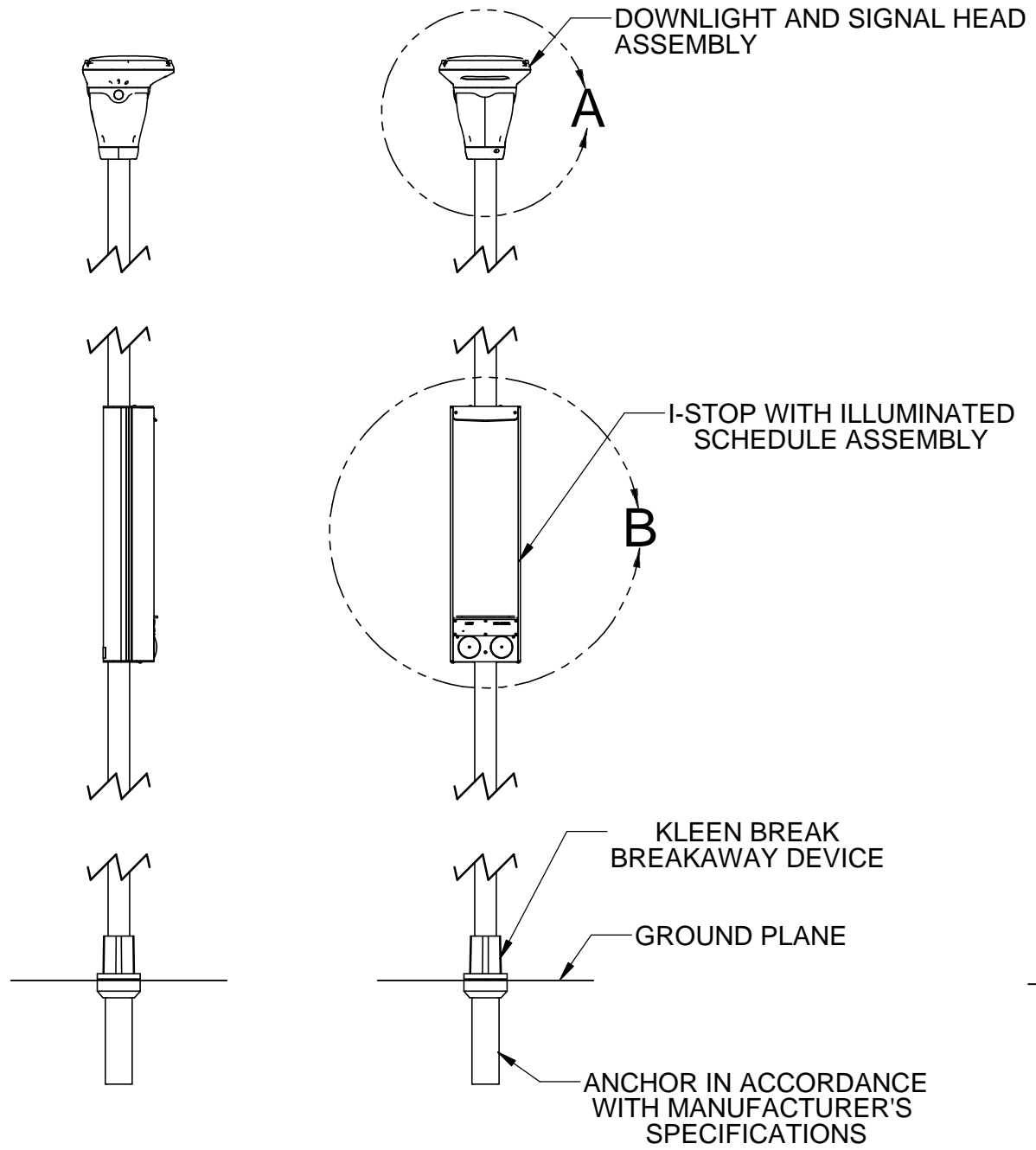

TWO FEATURE i-STOP OVERVIEW:

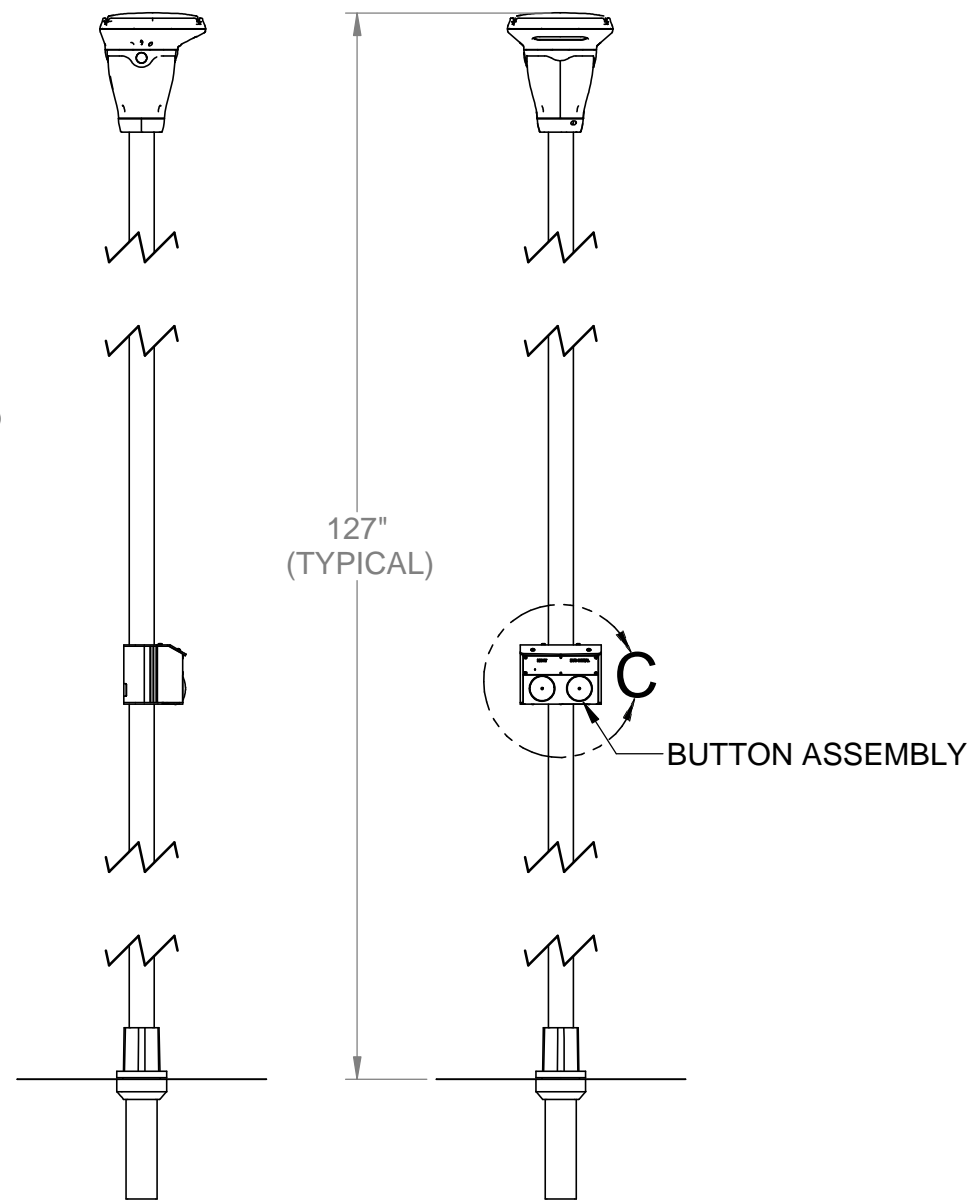

i-STOP COMPONENT OVERVIEW:

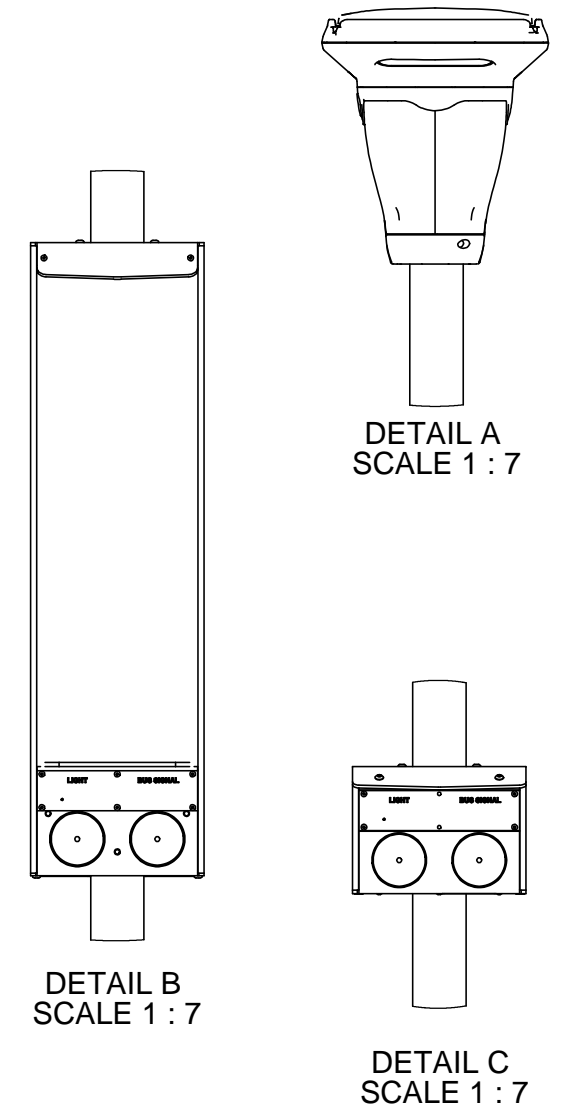

Carmanah Technologies Inc.
 Building 4-203 Harbour Road
 Victoria, BC Canada V9A 3S2
 Tel [250] 380-0052
 Fax [250] 380-0062

COPYRIGHT © 2003 BY
 Carmanah Technologies Inc. Victoria, BC, Canada
 ALL RIGHTS RESERVED. NO PART OF THIS
 DOCUMENT MAY BE REPRODUCED STORED IN A
 RETRIEVAL SYSTEM, OR TRANSMITTED IN ANY
 FORM, WITHOUT THE WRITTEN PERMISSION OF
 Carmanah Technologies Inc.

TITLE

INSTALLATION OVERVIEW, i-STOP ON BREAKAWAY BASE

DRAWN BY
 Trevor Harmon
 DATE
 05-Nov-2006

DRAWING NO
51655

REVISION
X1

SHEET
1 OF 1