



June 1, 2008

In Reply Refer To: HSSD/CC-88A

Archived

Dean Sicking, Ph.D., P.E.  
Director, Midwest Roadside Safety Facility  
University of Nebraska – Lincoln  
527 Nebraska Hall  
Lincoln, NE 68588-0529

For

Dear Dr. Sicking:

This is in response to your letter dated February 28, 2007, requesting Federal Highway Administration (FHWA) acceptance of the Sequential Kinking Terminal (SKT) and the FLared Energy Absorbing Terminal (FLEAT) using wood posts when connecting to the Midwest Guardrail System (MGS). FHWA Acceptance Letter CC-88, dated March 8, 2005, accepted these combinations based on testing with steel posts. You requested that we find these modified devices acceptable for use on the National Highway System (NHS) under the provisions of National Cooperative Highway Research Program (NCHRP) Report 350 "Recommended Procedures for the Safety Performance Evaluation of Highway Features." We provided an informal opinion accepting this device on March 15, 2007, and have been working with you to finalize the drawings for this final acceptance package.

### **Introduction**

The FHWA guidance on crash testing of roadside safety hardware is contained in a memorandum dated July 25, 1997, titled "INFORMATION: Identifying Acceptable Highway Safety Features."

Two different anchor designs were used in the original MGS testing, a two post, ground line strut design and a large single post with a soil plate alternative. The upper parts of these designs were identical and Test 3-34 was conducted on the FLEAT with both anchor designs. Test FLEAT-5 used the two post and strut alternative while test FLEAT -7 used the single post anchor system. Videos, photos and reports on these tests were submitted with your original request for approval. At your request we only included the double post design in its approval letter.

Our original letter also indicated that both steel and wood post options were acceptable but you did not provide a drawing of the wood post option.

Only

## Findings

Based on prior testing discussed above we find the following terminal designs as shown in the enclosed drawings acceptable for use on the NHS under the range of conditions tested, when proposed by a State:

- 1) SKT terminal for the MGS, steel and wood post options.
- 2) FLEAT terminal for the MGS, steel and wood post options.
- 3) SKT with two post anchor with ground strut.
- 4) FLEAT with two post anchors with ground strut.

Please note the following standard provisions that apply to FHWA letters of acceptance:

- Our acceptance is limited to the crashworthiness characteristics of the devices and does not cover their structural features, nor conformity with the Manual on Uniform Traffic Control Devices.
- Any changes that may adversely influence the crashworthiness of the device will require a new acceptance letter.
- Should the FHWA discover that the qualification testing was flawed, that in-service performance reveals unacceptable safety problems, or that the device being marketed is significantly different from the version that was crash tested, it reserves the right to modify or revoke its acceptance.
- You will be expected to supply potential users with sufficient information on design and installation requirements to ensure proper performance.
- You will be expected to certify to potential users that the hardware furnished has essentially the same chemistry, mechanical properties, and geometry as that submitted for acceptance, and that they will meet the crashworthiness requirements of FHWA and NCHRP Report 350.
- To prevent misunderstanding by others, this letter of acceptance, designated as number CC-88A shall not be reproduced except in full. This letter, and the test documentation upon which this letter is based, is public information. All such letters and documentation may be reviewed at our office upon request.
- The SKT and FLEAT w-beam guardrail terminals are patented devices and considered "proprietary." The use of proprietary devices *specified by a highway agency* for use on Federal-aid projects must meet one of the following criteria: (a) it must be supplied through competitive bidding with equally suitable unpatented items; (b) the highway agency must certify that it is essential for synchronization with existing highway facilities or that no equally suitable alternative exists ;or (c) it must be used for research or for a distinctive type of construction on relatively short sections of road for experimental purposes. Our regulations concerning proprietary products are contained in Title 23, Code of Federal Regulations, Section 635.411.

- This Acceptance Letter shall not be construed as authorization or consent by the FHWA to use, manufacture, or sell any patented device for which the applicant is not the patent holder. The Acceptance Letter is limited to the crashworthiness characteristics of the candidate device, and the FHWA is neither prepared nor required to become involved in issues concerning patent law. Patent issues, if any, are to be resolved by the applicant.

Sincerely yours,

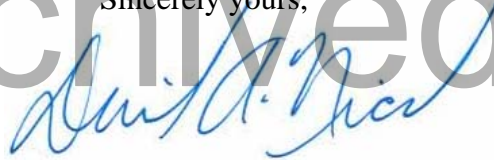

David A. Nicol  
Director, Office of Safety Design  
Office of Safety

Enclosures

Archived  
For  
Research  
and  
Historical  
Purposes  
Only

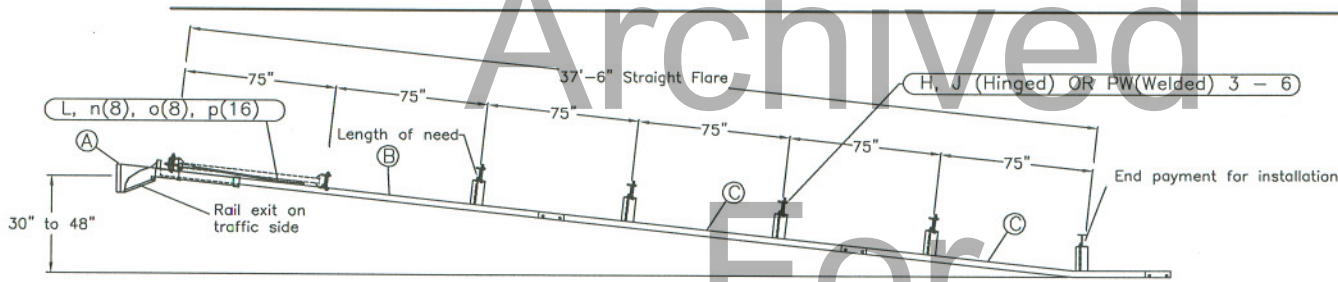

TRAFFIC → PLAN

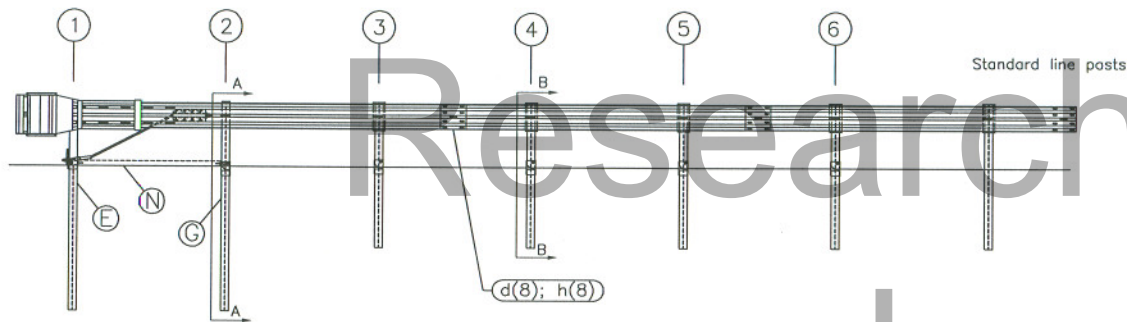

ELEVATION

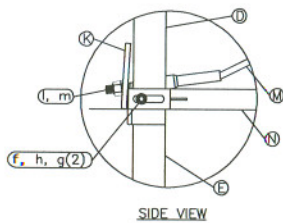

POST #1 CONNECTION DETAILS

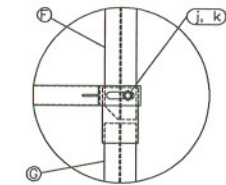
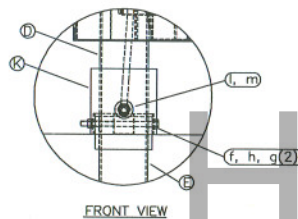

Side View Detail of Post #2

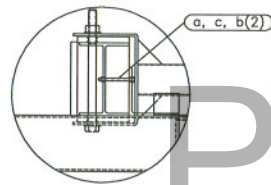

Impact Head Connection Detail

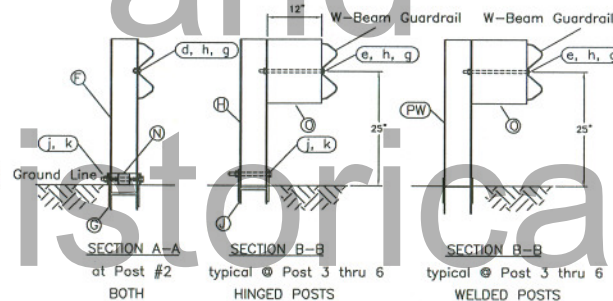

ITEM	QTY	BILL OF MATERIALS	ITEM NO.
A	1	IMPACT HEAD	F3000
B	1	W-BEAM GUARDRAIL, END SECTION, 12 Ga.	F1303 MGS
C	2	W-BEAM GUARDRAIL, 12 Ga.	G1203 MGS
D	1	FIRST POST ASSEMBLY TOP	UHP1A
E	1	FIRST POST ASSEMBLY BOTTOM	HP1B
F	1	SECOND POST ASSEMBLY TOP	UHP2A
G	1	SECOND POST ASSEMBLY BOTTOM	HP2B
K	1	BEARING PLATE	E750
L	1	CABLE ANCHOR BOX	S760
M	1	BCT CABLE ANCHOR ASSEMBLY	E770
N	1	GROUND STRUT HINGED POST	S785
O	4	ROUTED MGS TIMBER BLOCKOUT OR RECYC. EQUIV.	P618
HARDWARE (ALL DIMENSIONS IN INCHES)			
a	2	1/4 x 4 HEX BOLT GRD 5	B140404A
b	4	1/4 WASHER	W014
c	2	1/4 HEX NUT	N014
d	17	5/8 Dia. x 1 1/4 SPLICE BOLT (POST #2)	B580122
e	4	5/8 Dia. x 14 H.G.R. BOLT (POSTS 3 THRU 6)	B581402
f	1	5/8 Dia. x 9 HEX BOLT GRD 5	B580904A
g	7	5/8 WASHER	W050
h	22	5/8 Dia. H.G.R. NUT	N050
i	2	1 ANCHOR CABLE HEX NUT	H100
m	2	1 ANCHOR CABLE WASHER	W100
n	8	CABLE ANCHOR BOX SHOULDER BOLT	S858A
o	8	1/2 A325 STRUCTURAL NUT	N055A
p	16	1 1/16 OD x 9/16 ID A325 STR. WASHER	W050A
WELDED POST QUANTITIES			
*PW	4	STEEL BREAKAWAY POST	UPB621
*j	1	3/4 Dia. x 8 1/2 HEX BOLT GRD 5	B340854A
*k	1	3/4 Dia. HEX NUT	N030
HINGED POST QUANTITIES			
*H	4	BREAKAWAY LINE POST TOP	UHP3A
*J	4	BREAKAWAY LINE POST BOTTOM	UHP3B
*j	5	3/4 Dia. x 8 1/2 HEX BOLT GRD 5	B340854A
*k	5	3/4 Dia. HEX NUT	N030

GENERAL NOTES:

1. Breakaway posts are required with the FLEAT.
2. All bolts, nuts, cable assemblies, cable anchors and bearing plates shall be galvanized.
3. The lower sections of the posts shall not protrude more than 4 in above the ground (measured along a 5' cord). Site grading may be necessary to meet this requirement.
4. The lower sections of the hinged posts should not be driven with the upper post attached. If the post is placed in a drilled hole, the backfill material must be satisfactorily compacted to prevent settlement.
5. When rock is encountered, a 10" Ø post hole, 20 in into the rock surface may be used if approved by the engineer. Granular material will be placed in the bottom of the hole, approximately 2.5" deep to provide drainage. The first two posts can be field cut to length, placed in the hole and backfilled with adequately compacted material excavated from the hole.
6. The breakaway cable assembly must be taut. A locking device (vice grips or channel lock pliers) should be used to prevent the cable from twisting when tightening nuts.

	FLEAT Terminal Midwest Guardrail System Universal Steel Posts Hinged and Welded Options	Drawn:	1
		Date:	04/24/2008
Big Spring, TX Phone: 409-363-8455 or Phone: 409-366-0921	Drawing Name: FLT-MGS-S-UP	Scale: NONE	By: JRR

Only

# Archived

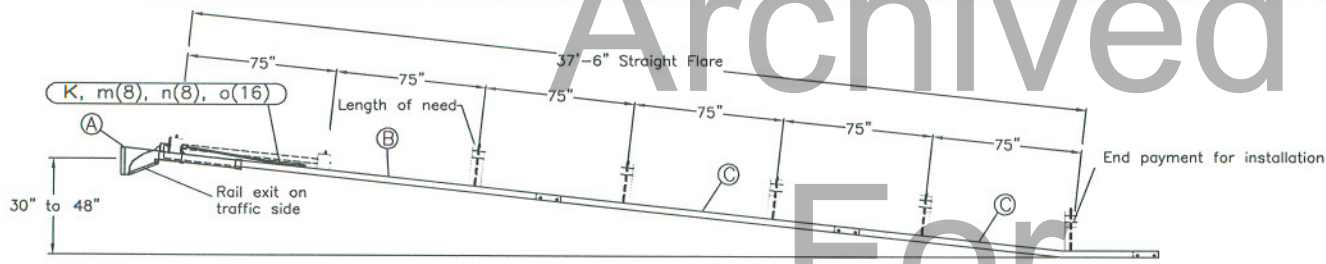

TRAFFIC → PLAN

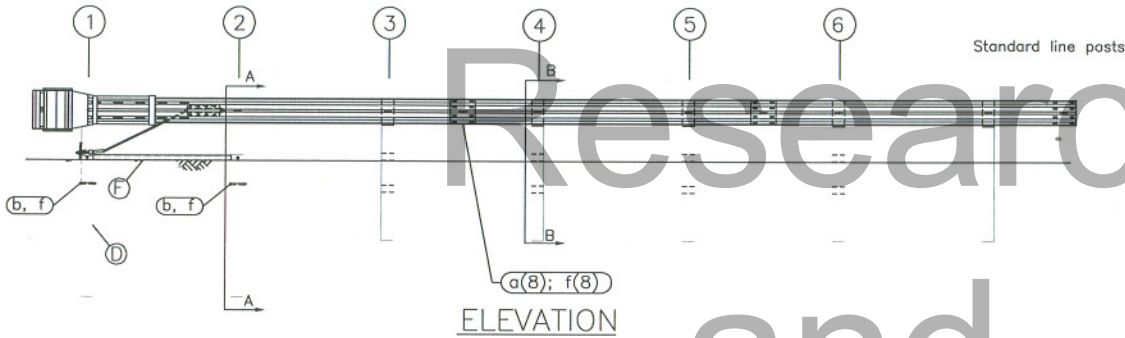

ELEVATION

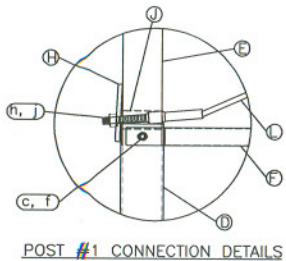

POST #1 CONNECTION DETAILS

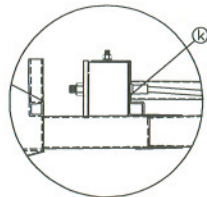

IMPACT HEAD CONNECTION DETAIL

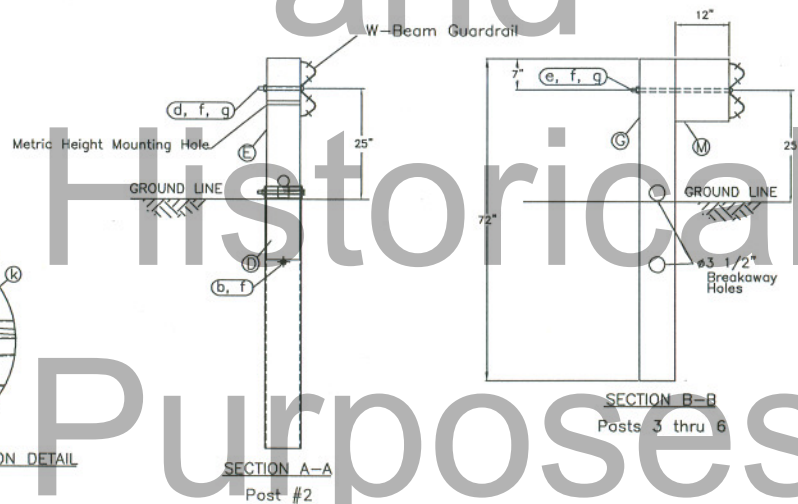

SECTION A-A Post #2

SECTION B-B Posts 3 thru 6

ITEM	QTY	BILL OF MATERIALS	ITEM NO.
A	1	IMPACT HEAD	F3000
B	1	W-BEAM GUARDRAIL END SECTION, 12 Ga.	F1303 MGS
C	2	W-BEAM GUARDRAIL, 12 Ga.	G1203 MGS
D	2	FOUNDATION TUBE	E730/S730
E	2	UNIVERSAL BCT WOOD POST	UP650
F	1	GROUND STRUT	E780
G	4	UNIVERSAL CRT WOOD POST	UP671
H	1	BEARING PLATE	E750
J	1	PIPE SLEEVE	E740
K	1	CABLE ANCHOR BOX	S760
L	1	BCT CABLE ANCHOR ASSEMBLY	E770
M	4	MGS TIMBER BLOCKOUT OR RECYC. EQUIV.	P677
HARDWARE (ALL DIMENSIONS IN INCHES)			
a	16	5/8" x 1 1/4" SPLICE BOLT	B580122
b	2	5/8" x 8" HEX BOLT	B580804
c	2	5/8" x 10" HEX BOLT	B581004
d	1	5/8" x 10" H.G.R. BOLT	B581002
e	4	5/8" x 22" H.G.R. BOLT	B582202
f	25	5/8" H.G.R. NUT	N050
g	5	H.G.R. WASHER	W050
h	2	1 ANCHOR CABLE HEX NUT	N100
j	2	1 ANCHOR CABLE WASHER	W100
k	2	3/8 x 3 LAG SCREW	E350
m	8	CABLE ANCHOR BOX SHOULDER BOLT	SB58A
n	8	1/2 A325 STRUCTURAL NUT	N055A
o	16	1 1/16 OD x 9/16 ID A325 STR. WASHER	W050A

**GENERAL NOTES:**

1. Breakaway posts are required with the FLEAT.
2. All bolts, nuts, cable assemblies, cable anchors and bearing plates shall be galvanized.
3. The foundation tubes shall not protrude more than 4 in above the ground (measured along a 5' cord). Site grading may be necessary to meet this requirement.
4. When rock is encountered, a 12"  $\phi$  post hole, 20 in into the rock surface may be used if approved by the engineer. Granular material will be placed in the bottom of the hole, approximately 2.5" deep to provide drainage. The soil tubes can be field cut to length, placed in the hole and backfilled with adequately compacted material excavated from the hole.
5. The breakaway cable assembly must be taut. A locking device (vice grips or channel lock pliers) should be used to prevent the cable from twisting when tightening nuts.
6. The soil tubes may be driven with an approved driving head. They shall not be driven with the post in the tube.
7. The wood blockouts should be "toe-nailed" to the rectangular wood posts to prevent them from turning when the wood shrinks.



Big Spring, TX  
Phone: 432-263-2435  
or Phone: 330-346-0721

FLEAT Terminal  
Midwest Guardrail System  
Universal Wood Posts

Drawing Name:  
FLT-MGS-W UP

Scale:  
NONE

Sheet:  
**1**  
Date:  
04/24/2008  
By:  
JRR  
Rec:  
[Signature]

# Only

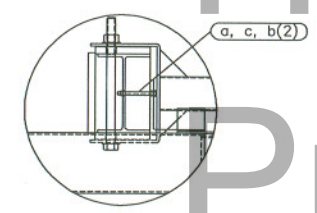
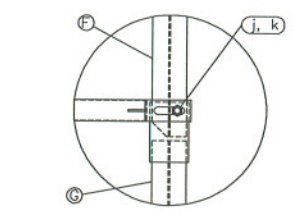
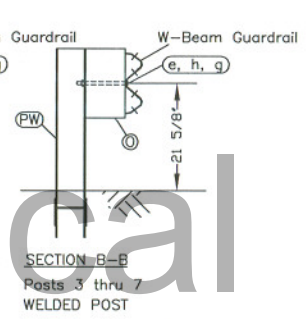
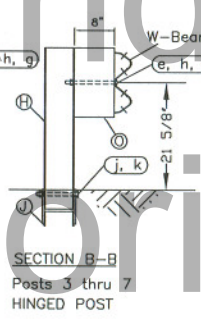
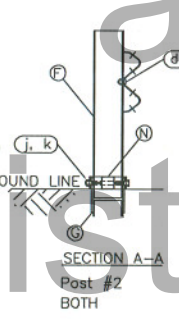
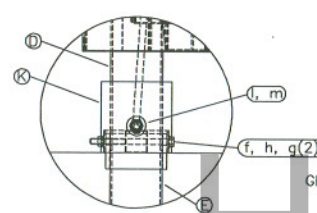
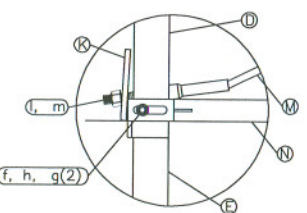
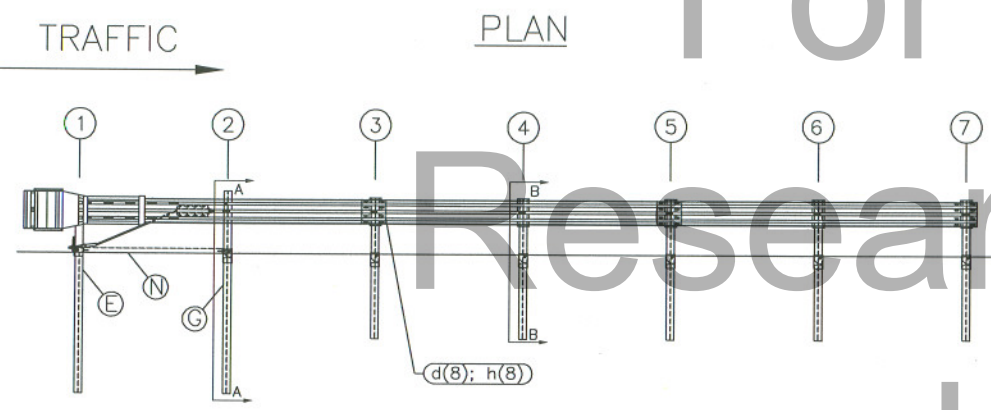
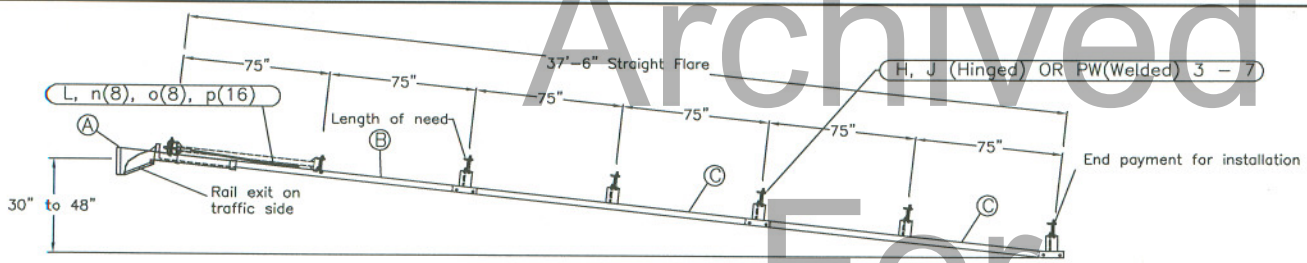

Side View Detail of Post #2

Impact Head Connection Detail

ITEM	QTY	BILL OF MATERIALS	ITEM NO.
A	1	IMPACT HEAD	F3000
B	1	W-BEAM GUARDRAIL END SECTION, 12 Ga.	SF1303
C	2	W-BEAM GUARDRAIL, 12 Ga.	G1203
D	1	FIRST POST ASSEMBLY TOP	UHP1A
E	1	FIRST POST ASSEMBLY BOTTOM	HP1B
F	1	SECOND POST ASSEMBLY TOP	UHP2A
G	1	SECOND POST ASSEMBLY BOTTOM	HP2B
K	1	BEARING PLATE	E750
L	1	CABLE ANCHOR BOX	S760
M	1	BCT CABLE ANCHOR ASSEMBLY	E770
N	1	GROUND STRUT HINGED POST	S785
O	5	ROUTED TIMBER BLOCKOUT OR RECYC. EQUIV.	P616

HARDWARE (ALL DIMENSIONS IN INCHES)			
a	2	1/4 x 4 HEX BOLT GRD 5	B140404A
b	4	1/4 WASHER	W014
c	2	1/4 HEX NUT	N014
d	17	5/8 Dia. x 1 1/4 SPLICE BOLT (POST #2)	B580122
e	5	5/8 Dia. x 10 H.G.R. BOLT (POSTS 3 THRU 7)	B581002
f	1	5/8 Dia. x 9 HEX BOLT GRD 5	B580904A
g	8	5/8 WASHER	W050
h	23	5/8 Dia. H.G.R. NUT	N050
i	2	1 ANCHOR CABLE HEX NUT	N100
m	2	1 ANCHOR CABLE WASHER	W100
n	8	CABLE ANCHOR BOX SHOULDER BOLT	S858A
o	8	1/2 A325 STRUCTURAL NUT	N055A
p	16	1 1/16 OD x 9/16 ID A325 STR. WASHER	W050A

WELDED POST QUANTITIES			
*PW	5	STEEL BREAKAWAY POST	UPB621
*j	1	3/4 Dia. x 8 1/2 HEX BOLT GRD 5	B340854A
*k	1	3/4 Dia. HEX NUT	N030

HINGED POST QUANTITIES			
*H	5	BREAKAWAY LINE POST TOP	UHP3A
*J	5	BREAKAWAY LINE POST BOTTOM	UHP3B
*j	6	3/4 Dia. x 8 1/2 HEX BOLT GRD 5	B340854A
*k	6	3/4 Dia. HEX NUT	N030

- GENERAL NOTES:
- Breakaway posts are required with the FLEAT.
  - All bolts, nuts, cable assemblies, cable anchors and bearing plates shall be galvanized.
  - The lower sections of the posts shall not protrude more than 4 in above the ground (measured along a 5' cord). Site grading may be necessary to meet this requirement.
  - The lower sections of the hinged posts should not be driven with the upper post attached. If the post is placed in a drilled hole, the backfill material must be satisfactorily compacted to prevent settlement.
  - When rock is encountered, a 10" Ø post hole, 20 in into the rock surface may be used if approved by the engineer. Granular material will be placed in the bottom of the hole, approximately 2.5" deep to provide drainage. The first two posts can be field cut to length, placed in the hole and backfilled with adequately compacted material excavated from the hole.
  - The breakaway cable assembly must be taut. A locking device (vice grips or channel lock pliers) should be used to prevent the cable from twisting when tightening nuts.

Big Spring, TX  
Phone: 432-263-2435  
or Phone: 330-346-0721

FLEAT Terminal Metric Height Universal Steel Posts Hinged and Welded Options		Sheet: <b>1</b>
Drawing Name: FLT-M-S UP	Scale: NONE	Date: 04/24/2008
By: JRR	Rev: A	

Archived For Research and Historical Purposes Only

Archived For Research Historical Purposes Only

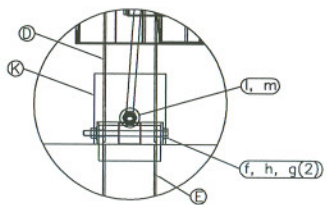
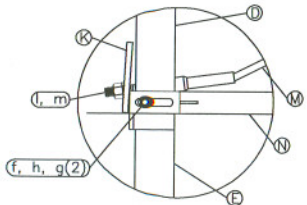
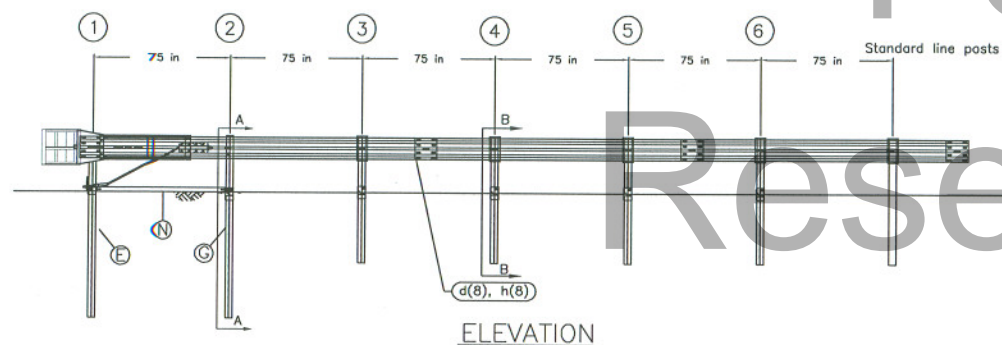
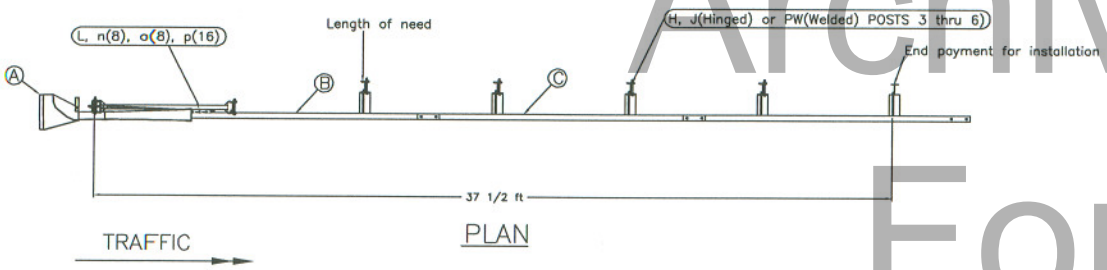

POST #1 CONNECTION DETAILS

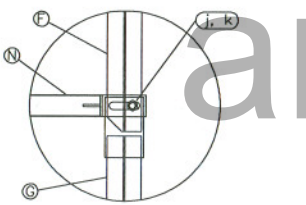

Side View Detail of Post #2

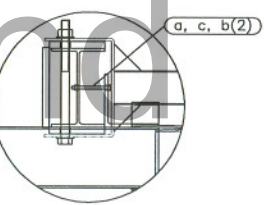

Impact Head Connection Detail

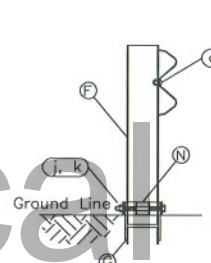

SECTION A-A  
at Post #2  
BOTH

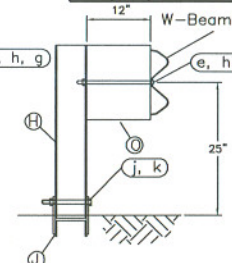

SECTION B-B  
typical @ Post 3 thru 6  
HINGED POSTS

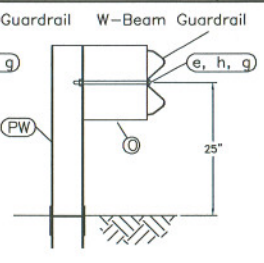

SECTION B-B  
typical @ Post 3 thru 6  
WELDED POSTS

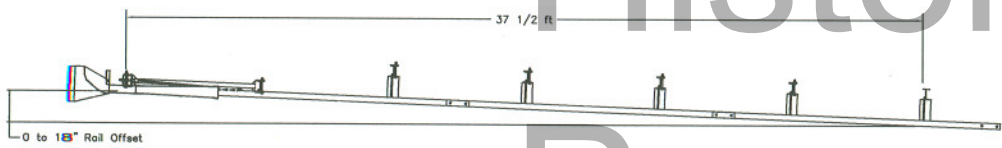

OPTIONAL FLARED INSTALLATION  
25:1 maximum flare rate

- GENERAL NOTES:**
1. Breakaway posts are required with the SKT.
  2. All bolts, nuts, cable assemblies, cable anchors and bearing plates shall be galvanized.
  3. The SKT can be flared at a rate of up to 25:1 to prevent the impact head from encroaching on the shoulder.
  4. The lower sections of the posts shall not protrude more than 4" above the ground (measured along a 5' cord). Site grading may be necessary to meet this requirement.
  5. The lower section of the hinged posts should not be driven with the upper post attached. If the post is placed in a drilled hole, the backfill material must be satisfactorily compacted to prevent settlement.
  6. When rock is encountered, a 10" Ø post hole, 20" into the rock surface may be used if approved by the engineer. Granular material will be placed in the bottom of the hole, approximately 2.5" deep to provide drainage. Posts 1 & 2 can be field cut to length, placed in the hole and backfilled with adequately compacted material excavated from the hole.
  7. The breakaway cable assembly must be taut. A locking device (vice grips or channel lock pliers) should be used to prevent the cable from twisting when tightening nuts.
  8. A site evaluation should be considered if there is less than 25' between the outlet side of the terminal and any adjacent driving lane.

ITEM	QTY	BILL OF MATERIALS	ITEM NO.
A	1	IMPACT HEAD	S3000
B	1	W-BEAM GUARDRAIL END SECTION, 12 Ga.	S1303 MGS
C	2	W-BEAM GUARDRAIL, 12 Ga.	G1203 MGS
D	1	FIRST POST ASSEMBLY TOP	UHP1A
E	1	FIRST POST ASSEMBLY BOTTOM	HP1B
F	1	SECOND POST ASSEMBLY TOP	UHP2A
G	1	SECOND POST ASSEMBLY BOTTOM	HP2B
K	1	BEARING PLATE	E750
L	1	CABLE ANCHOR BOX	S760
M	1	BCT CABLE ANCHOR ASSEMBLY	E770
N	1	GROUND STRUT HINGED POST	S785
O	4	ROUTED MGS TIMBER BLOCKOUT OR RECYC. EQUIV.	P618

HARDWARE (ALL DIMENSIONS IN INCHES)			
a	2	1/4 x 4 HEX BOLT GRD 5	B140404A
b	4	1/4 WASHER	W014
c	2	1/4 HEX NUT	N014
d	17	5/8 Dia. x 1 1/4 SPLICE BOLT, POST #2	B580122
e	4	5/8 Dia. x 14 H.G.R. BOLT (POSTS 3 THRU 6)	B581402
f	1	5/8 Dia. x 9 HEX BOLT GRD 5	B580904A
g	7	5/8 WASHER	W050
h	22	5/8 Dia. H.G.R. NUT	N050
i	2	1 ANCHOR CABLE HEX NUT	N100
m	2	1 ANCHOR CABLE WASHER	W100
n	8	CABLE ANCHOR BOX SHOULDER BOLT	SB58A
o	8	1/2 A325 STRUCTURAL NUT	N055A
p	16	1 1/16 OD x 9/16 ID A325 STR. WASHER	W050A

WELDED POST QUANTITIES			
*PW	4	WELDED BREAKAWAY POST	UPB621
*j	1	3/4 Dia. x 8 1/2 HEX BOLT GRD 5	B340854A
*k	1	3/4 Dia. HEX NUT	N030

HINGED POST QUANTITIES			
*H	4	BREAKAWAY LINE POST TOP	UHP3A
*J	4	BREAKAWAY LINE POST BOTTOM	UHP3B
*j	5	3/4 Dia. x 8 1/2 HEX BOLT GRD 5	B340854A
*k	5	3/4 Dia. HEX NUT	N030

 Big Spring, TX Phone: 432-263-2435 or Phone: 330-346-0721	Sequential Kinking Terminal SKT-LITE Midwest Guardrail System Universal Steel Posts Hinged and Welded Options	Sheet <b>1</b> Date: 04/24/2008 By: JRR
	Drawing Name: SKT-MGS-LITE-S-UP	Scale: NONE

# Archived

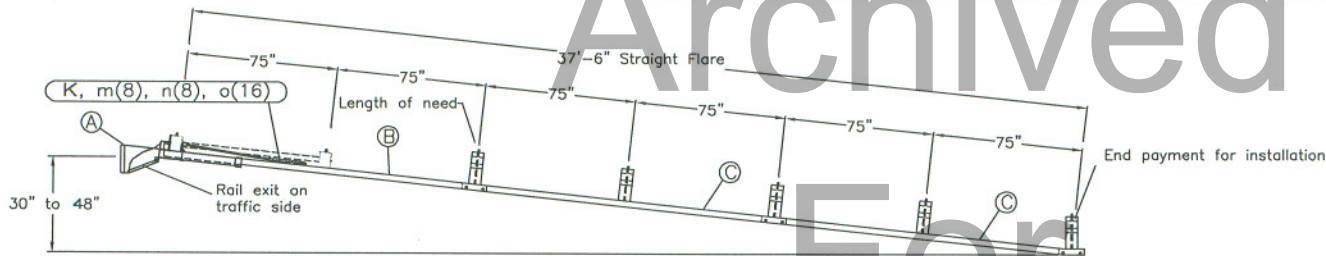

TRAFFIC →

PLAN

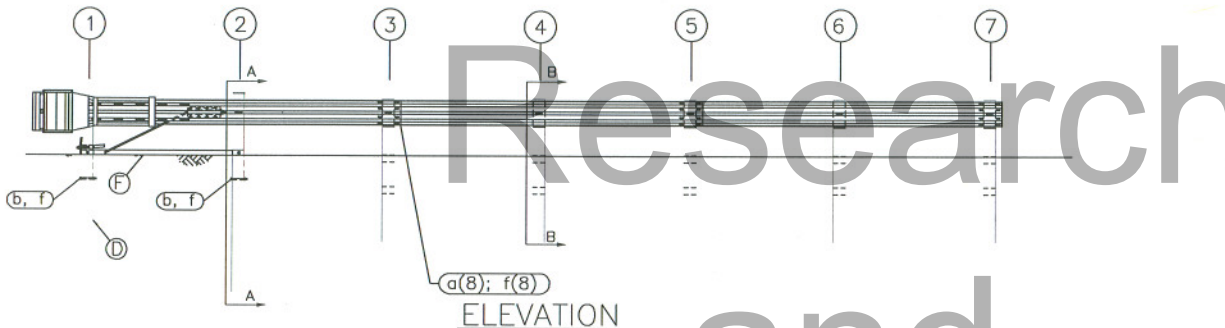

ELEVATION

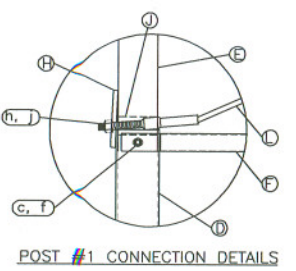

POST #1 CONNECTION DETAILS

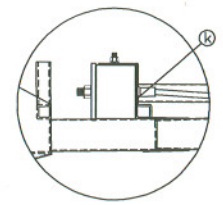

IMPACT HEAD CONNECTION DETAIL

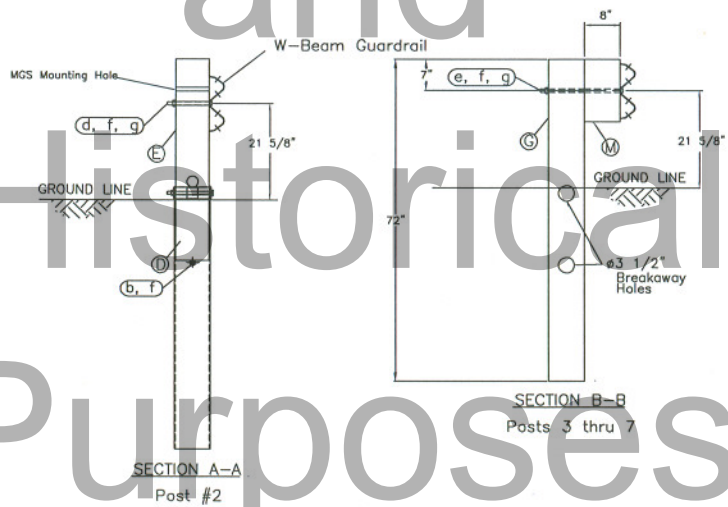

SECTION A-A  
Post #2

SECTION B-B  
Posts 3 thru 7

ITEM	QTY	BILL OF MATERIALS	ITEM NO.
A	1	IMPACT HEAD	F3000
B	1	W-BEAM GUARDRAIL END SECTION, 12 Ga.	F1303
C	2	W-BEAM GUARDRAIL, 12 Ga.	G1203
D	2	FOUNDATION TUBE	E730/S730
E	2	UNIVERSAL BCT WOOD POST	UP650
F	1	GROUND STRUT	E780
G	5	UNIVERSAL CRT WOOD POST	UP671
H	1	BEARING PLATE	E750
J	1	PIPE SLEEVE	E740
K	1	CABLE ANCHOR BOX	S760
L	1	BCT CABLE ANCHOR ASSEMBLY	E770
M	5	6"x8" TIMBER BLOCKOUT OR RECYC. EQUIV.	P675
HARDWARE (ALL DIMENSIONS IN INCHES)			
a	16	5/8" x 1 1/4" SPLICE BOLT	B580122
b	2	5/8" x 8" HEX BOLT	B580804
c	2	5/8" x 10" HEX BOLT	B581004
d	1	5/8" x 10" H.G.R. BOLT	B581002
e	5	5/8" x 18" H.G.R. BOLT	B581802
f	26	5/8" H.G.R. NUT	N050
g	6	H.G.R. WASHER	W050
h	2	1 ANCHOR CABLE HEX NUT	N100
j	2	1 ANCHOR CABLE WASHER	W100
k	2	3/8" x 3" LAG SCREW	E350
m	8	CABLE ANCHOR BOX SHOULDER BOLT	S858A
n	8	1/2" A325 STRUCTURAL NUT	N055A
o	16	1 1/16" OD x 9/16" ID A325 STR. WASHER	W050A

**GENERAL NOTES:**

1. Breakaway posts are required with the FLEAT.
2. All bolts, nuts, cable assemblies, cable anchors and bearing plates shall be galvanized.
3. The foundation tubes shall not protrude more than 4 in above the ground (measured along a 5' cord). Site grading may be necessary to meet this requirement.
4. When rock is encountered, a 12" Ø post hole, 20 in into the rock surface may be used if approved by the engineer. Granular material will be placed in the bottom of the hole, approximately 2.5" deep to provide drainage. The soil tubes can be field cut to length, placed in the hole and backfilled with adequately compacted material excavated from the hole.
5. The breakaway cable assembly must be taut. A locking device (vice grips or channel lock pliers) should be used to prevent the cable from twisting when tightening nuts.
6. The soil tubes may be driven with an approved driving head. They shall not be driven with the post in the tube.
7. The wood blockouts should be "toe-nailed" to the rectangular wood posts to prevent them from turning when the wood shrinks.

 Big Spring, TX Phone: 432-263-2435 or Phone: 350-346-0721	<b>FLEAT Terminal</b> <b>Metric Height</b> <b>Universal Wood Posts</b>	Sheet: <b>1</b>
	Drawing Name: FLT-M-W UP	Date: 04/24/2008
		By: JRR

# Only



Archived For Research and Historical Purposes Only

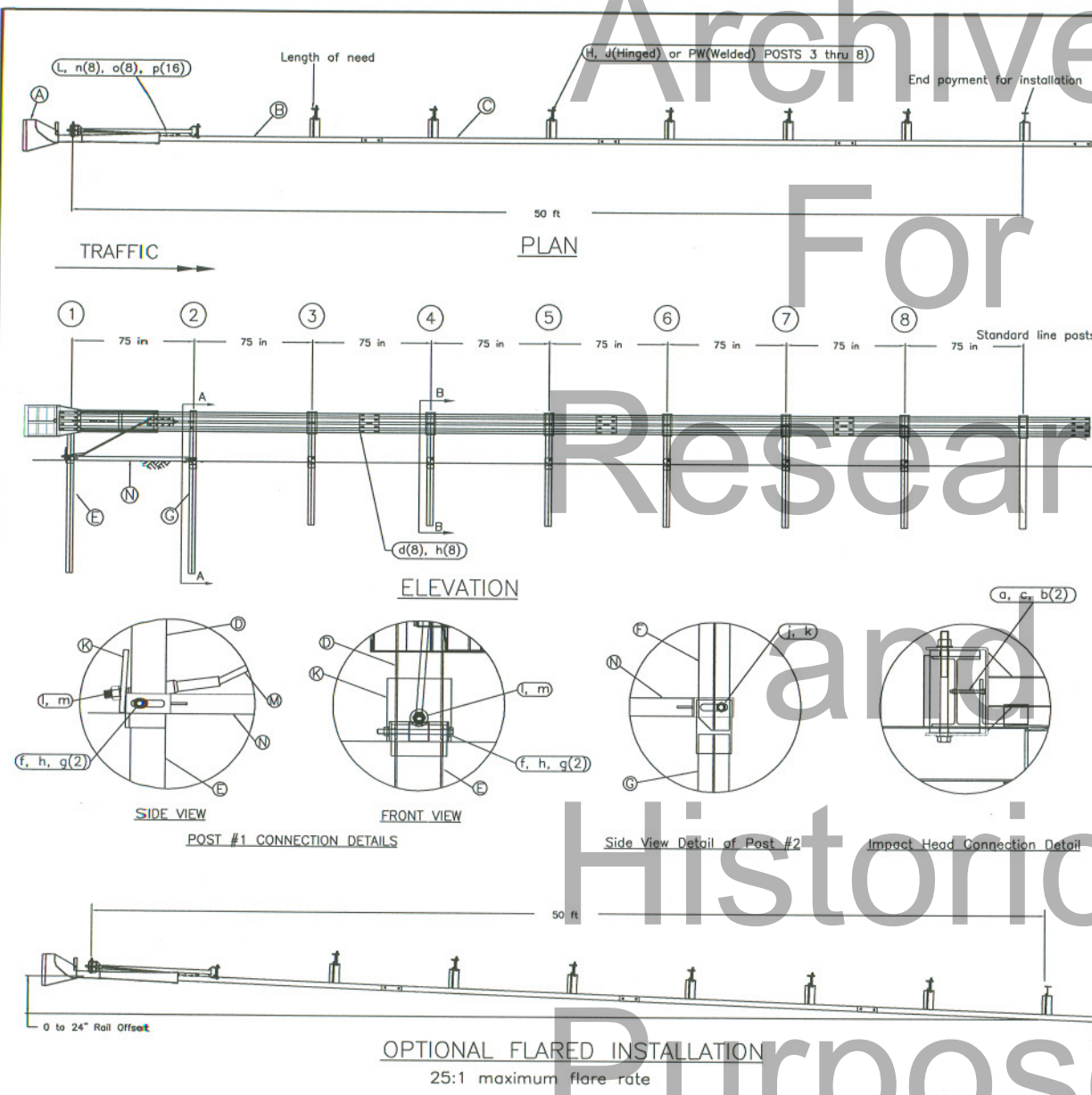

**GENERAL NOTES:**

1. Breakaway posts are required with the SKT.
2. All bolts, nuts, cable assemblies, cable anchors and bearing plates shall be galvanized.
3. The SKT can be flared at a rate of up to 25:1 to prevent the impact head from encroaching on the shoulder.
4. The lower sections of the posts shall not protrude more than 4" above the ground (measured along a 5' cord). Site grading may be necessary to meet this requirement.
5. The lower section of the hinged posts should not be driven with the upper post attached. If the post is placed in a drilled hole, the backfill material must be satisfactorily compacted to prevent settlement.
6. When rock is encountered, a 10" Ø post hole, 20" into the rock surface may be used if approved by the engineer. Granular material will be placed in the bottom of the hole, approximately 2.5" deep to provide drainage. Posts 1 & 2 can be field cut to length, placed in the hole and backfilled with adequately compacted material excavated from the hole.
7. The breakaway cable assembly must be taut. A locking device (vice grips or channel lock pliers) should be used to prevent the cable from twisting when tightening nuts.
8. A site evaluation should be considered if there is less than 25' between the outlet side of the terminal and any adjacent driving lane.

ITEM	QTY	BILL OF MATERIALS	ITEM NO.
A	1	IMPACT HEAD	S3000
B	1	W-BEAM GUARDRAIL END SECTION, 12 Ga.	S1303 MGS
C	3	W-BEAM GUARDRAIL, 12 Ga.	G1203 MGS
D	1	FIRST POST ASSEMBLY TOP	UHP1A
E	1	FIRST POST ASSEMBLY BOTTOM	HP1B
F	1	SECOND POST ASSEMBLY TOP	UHP2A
G	1	SECOND POST ASSEMBLY BOTTOM	HP2B
K	1	BEARING PLATE	E750
L	1	CABLE ANCHOR BOX	S760
M	1	BCT CABLE ANCHOR ASSEMBLY	E770
N	1	GROUND STRUT HINGED POST	S785
O	6	ROUTED MGS TIMBER BLOCKOUT OR RECYC. EQUIV.	P618

HARDWARE (ALL DIMENSIONS IN INCHES)			
a	2	1/4 x 4 HEX BOLT GRD 5	B140404A
b	4	1/4 WASHER	W014
c	2	1/4 HEX NUT	N014
d	25	5/8 Dia. x 1 1/4 SPLICE BOLT, POST #2	B580122
e	6	5/8 Dia. x 14 H.G.R. BOLT (POSTS 3 THRU 8)	B581402
f	1	5/8 Dia. x 9 HEX BOLT GRD 5	B580904A
g	9	5/8 WASHER	W050
h	32	5/8 Dia. H.G.R. NUT	N050
i	2	1 ANCHOR CABLE HEX NUT	N100
m	2	1 ANCHOR CABLE WASHER	W100
n	8	CABLE ANCHOR BOX SHOULDER BOLT	SB58A
o	8	1/2 A325 STRUCTURAL NUT	N055A
p	16	1 1/16 OD x 9/16 ID A325 STR. WASHER	W050A

WELDED POST QUANTITIES			
*PW	6	WELDED BREAKAWAY POST	UPB621
*j	1	3/4 Dia. x 8 1/2 HEX BOLT GRD 5	B340854A
*k	1	3/4 Dia. HEX NUT	N030

HINGED POST QUANTITIES			
*H	6	BREAKAWAY LINE POST TOP	UHP3A
*J	6	BREAKAWAY LINE POST BOTTOM	UHP3B
*j	7	3/4 Dia. x 8 1/2 HEX BOLT GRD 5	B340854A
*k	7	3/4 Dia. HEX NUT	N030

Big Spring, TX  
Phone: 432-263-2435  
or Phone: 330-346-0721

**Sequential Kinking Terminal  
SKT MGS Height  
Steel Post System  
Hinged and Welded Options**

SKT-MGS-S UP      Scale: NONE

Sheet: **1**

Date: 04/24/2008

By: JRR

Archived For Research and Historical Purposes Only

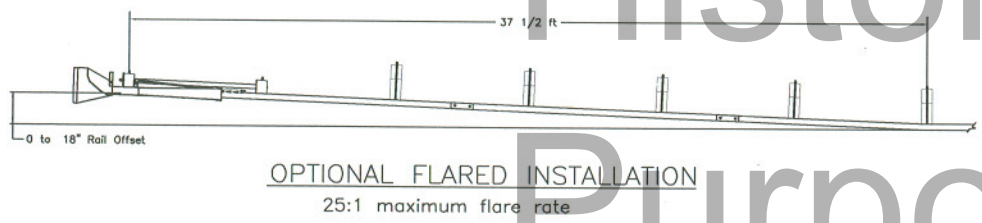
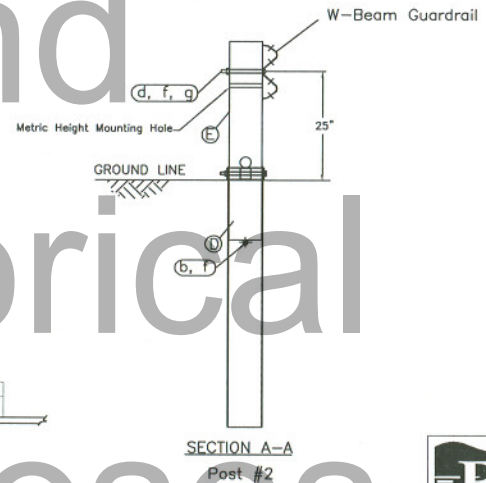
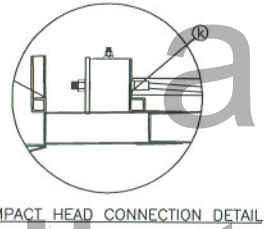
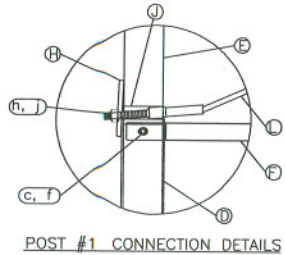
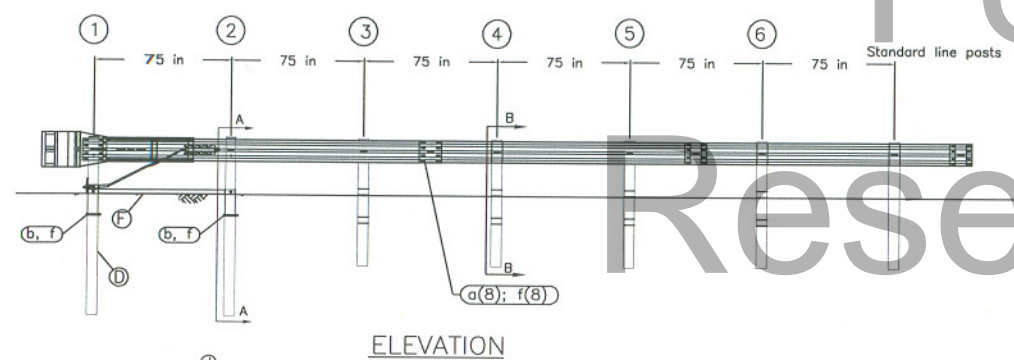
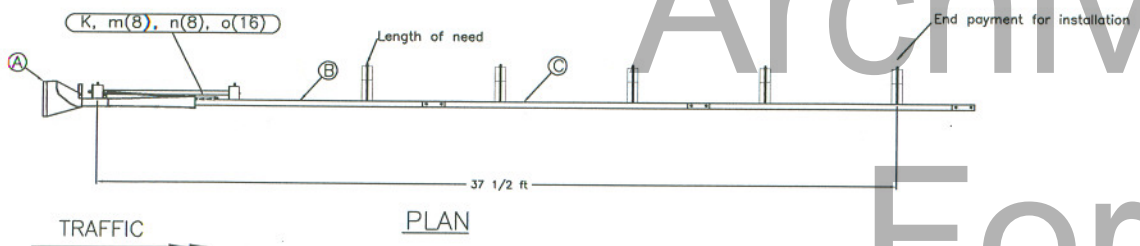

- GENERAL NOTES:**
1. Breakaway posts are required with the SKT.
  2. All bolts, nuts, cable assemblies, cable anchors and bearing plates shall be galvanized.
  3. The SKT can be flared at a rate of up to 25:1 to prevent the impact head from encroaching on the shoulder.
  4. The foundation tubes shall not protrude more than 4" above the ground (measured along a 5' cord). Site grading may be necessary to meet this requirement.
  5. When rock is encountered, a 12" Ø post hole, 20" into the rock surface may be used if approved by the engineer. Granular material will be placed in the bottom of the hole, approximately 2.5" deep to provide drainage. The soil tubes can be field cut to length, placed in the hole and backfilled with adequately compacted material excavated from the hole.
  6. The breakaway cable assembly must be taut. A locking device (vice grips or channel lock pliers) should be used to prevent the cable from twisting when tightening nuts.
  7. A site evaluation should be considered if there is less than 25' between the outlet side of the terminal and any adjacent driving lane.
  8. The soil tubes may be driven with an approved driving head. They shall not be driven with the post in the tube.
  9. The wood blockouts should be "toe-nailed" to the rectangular wood posts to prevent them from turning when the wood shrinks.

ITEM	QTY	BILL OF MATERIALS	ITEM NO.
A	1	IMPACT HEAD	S3000
B	1	W-BEAM GUARDRAIL END SECTION, 12 Ga.	S1303 MGS
C	2	W-BEAM GUARDRAIL, 12 Ga.	G1203 MGS
D	2	FOUNDATION TUBE	E730/S730
E	2	UNIVERSAL BCT WOOD POST	UP650
F	1	GROUND STRUT	E780
G	4	UNIVERSAL CRT WOOD POST	UP671
H	1	BEARING PLATE	E750
J	1	PIPE SLEEVE	E740
K	1	CABLE ANCHOR BOX	S760
L	1	BCT CABLE ANCHOR ASSEMBLY	E770
M	4	MGS TIMBER BLOCKOUT OR EQUIV.	P677

HARDWARE (ALL DIMENSIONS IN INCHES)			
a	16	5/8" x 1 1/4" SPLICE BOLT	B580122
b	2	5/8" x 8" HEX BOLT	B580804
c	2	5/8" x 10" HEX BOLT	B581004
d	1	5/8" x 10" H.G.R. BOLT	B581002
e	4	5/8" x 22" H.G.R. BOLT	B582202
f	25	5/8" H.G.R. NUT	N050
g	5	H.G.R. WASHER	W050
h	2	1" ANCHOR CABLE HEX NUT	N100
j	2	1" ANCHOR CABLE WASHER	W100
k	2	3/8" x 3" LAG SCREW	E350
m	8	CABLE ANCHOR BOX SHOULDER BOLT	S858A
n	8	1/2" A325 STRUCTURAL NUT	N055A
o	16	1 1/16" OD x 9/16" ID A325 STR. WASHER	W050A

Big Spring, TX  
Phone: 432-263-2435  
or Phone: 330-346-0721

Sequential Kinking Terminal  
SKT LITE - Assembly  
Midwest Guardrail System  
Universal Wood Posts

Sheet: **1**

Date: 04/24/2008

Drawing Name: SKT-MGS-LITE-W UP

Scale: NONE

By: JRR

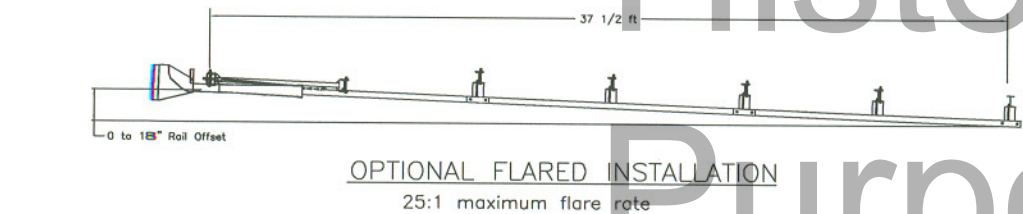
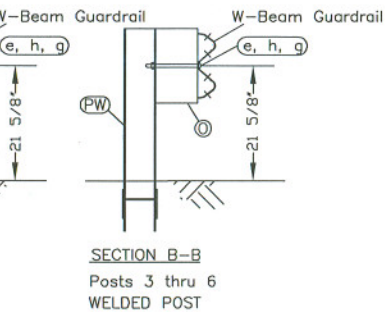
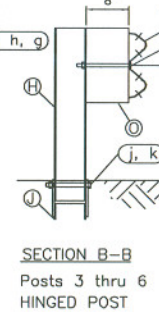
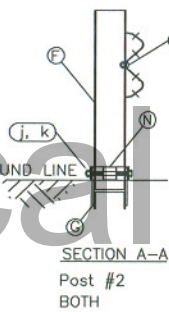
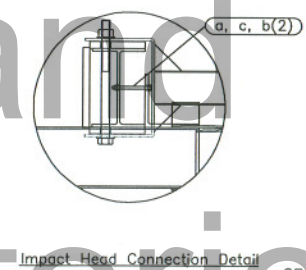
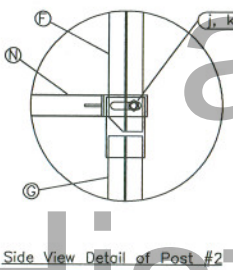
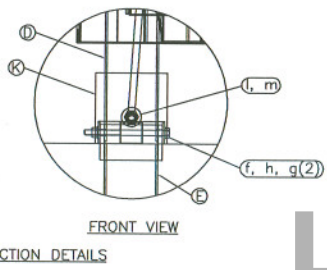
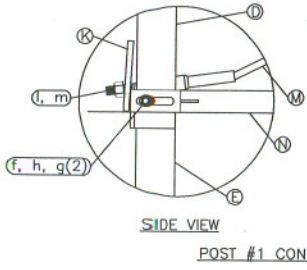
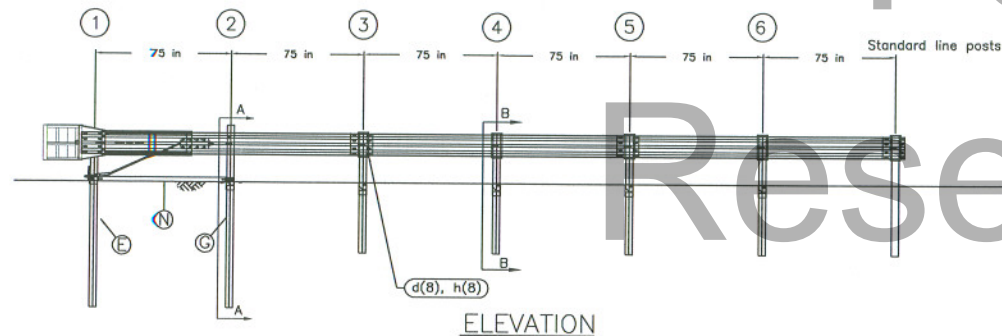
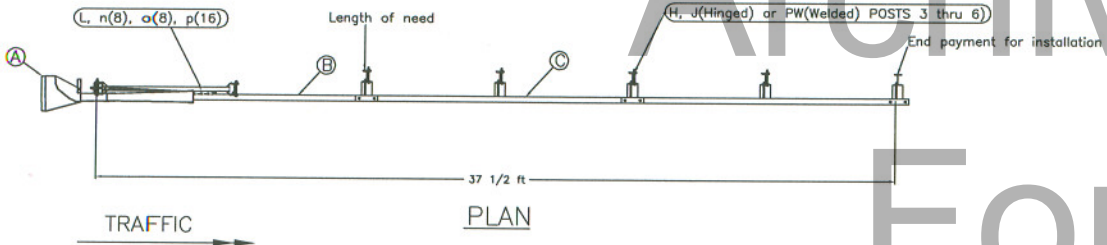

**GENERAL NOTES:**

- Breakaway posts are required with the SKT.
- All bolts, nuts, cable assemblies, cable anchors and bearing plates shall be galvanized.
- The SKT can be flared at a rate of up to 25:1 to prevent the impact head from encroaching on the shoulder.
- The lower sections of the posts shall not protrude more than 4" above the ground (measured along a 5' cord). Site grading may be necessary to meet this requirement.
- The lower section of the hinged posts should not be driven with the upper post attached. If the post is placed in a drilled hole, the backfill material must be satisfactorily compacted to prevent settlement.
- When rock is encountered, a 10" Ø post hole, 20" into the rock surface may be used if approved by the engineer. Granular material will be placed in the bottom of the hole, approximately 2.5" deep to provide drainage. Posts 1 & 2 can be field cut to length, placed in the hole and backfilled with adequately compacted material excavated from the hole.
- The breakaway cable assembly must be taut. A locking device (vice grips or channel lock pliers) should be used to prevent the cable from twisting when tightening nuts.
- A site evaluation should be considered if there is less than 25' between the outlet side of the terminal and any adjacent driving lane.

ITEM	QTY	BILL OF MATERIALS	ITEM NO.
A	1	IMPACT HEAD	S3000
B	1	W-BEAM GUARDRAIL END SECTION, 12 Ga.	S1303/5
C	2/1	W-BEAM GUARDRAIL, 12 Ga.	G1203
D	1	FIRST POST ASSEMBLY TOP	UHP1A
E	1	FIRST POST ASSEMBLY BOTTOM	HP1B
F	1	SECOND POST ASSEMBLY TOP	UHP2A
G	1	SECOND POST ASSEMBLY BOTTOM	HP2B
K	1	BEARING PLATE	E750
L	1	CABLE ANCHOR BOX	S760
M	1	BCT CABLE ANCHOR ASSEMBLY	E770
N	1	GROUND STRUT HINGED POST	S785
O	4	ROUTED TIMBER BLOCKOUT/RECYC. EQUIV.	P616

HARDWARE (ALL DIMENSIONS IN INCHES)			
a	2	1/4 x 4 HEX BOLT GRD 5	B140404A
b	4	1/4 WASHER	W014
c	2	1/4 HEX NUT	N014
d	17/9	5/8 Dia. x 1 1/4 SPLICE BOLT, POST #2	B580122
e	4	5/8 Dia. x 10 H.G.R. BOLT (POSTS 3 THRU 6)	B581002
f	1	5/8 Dia. x 9 HEX BOLT GRD 5	B580904A
g	7	5/8 WASHER	W050
h	22/14	5/8 Dia. H.G.R NUT	N050
i	2	1 ANCHOR CABLE HEX NUT	N100
m	2	1 ANCHOR CABLE WASHER	W100
n	8	CABLE ANCHOR BOX SHOULDER BOLT	SB58A
o	8	1/2 A325 STRUCTURAL NUT	N055A
p	16	1 1/16 OD x 9/16 ID A325 STR. WASHER	W050A

WELDED POST QUANTITIES			
*PW	4	WELDED BREAKAWAY POST	UPB621
*j	1	3/4 Dia. x 8 1/2 HEX BOLT GRD 5	B340854A
*k	1	3/4 Dia. HEX NUT	N030

HINGED POST QUANTITIES			
*H	4	BREAKAWAY LINE POST TOP	UHP3A
*J	4	BREAKAWAY LINE POST BOTTOM	UHP3B
*j	5	3/4 Dia. x 8 1/2 HEX BOLT GRD 5	B340854A
*k	5	3/4 Dia. HEX NUT	N030

Big Spring, TX  
Phone: 432-263-2435  
or Phone: 330-346-0721

Sequential Kinking Terminal  
SKT LITE Metric Height  
Steel Post System  
Hinged and Welded Options

SKT-M-LITE-S-UP

Sheet: **1**

Date: 04/24/2008

By: JRR

Scale: NONE

Only

Archived

For Research

and Historical Purposes

Only

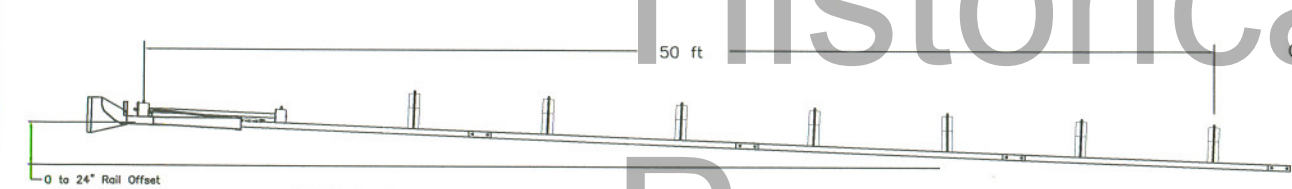
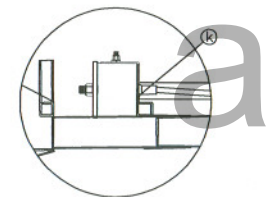
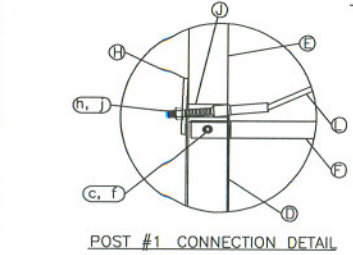
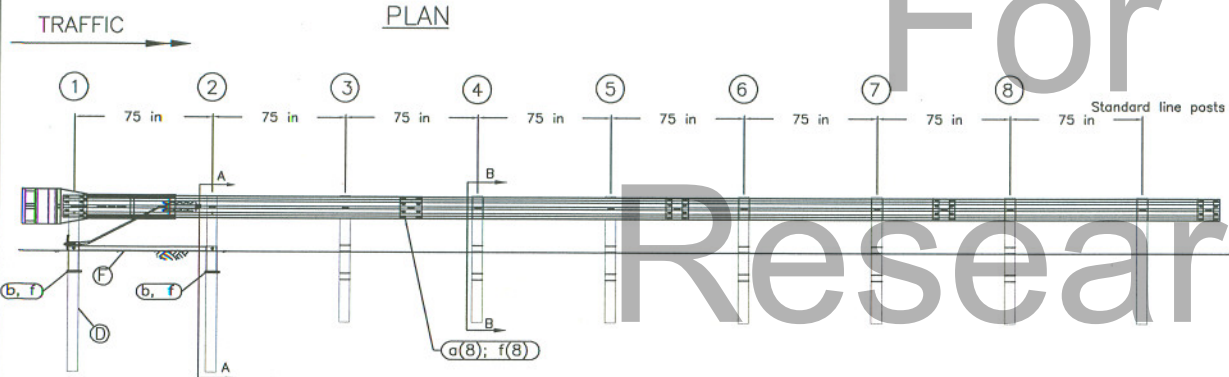
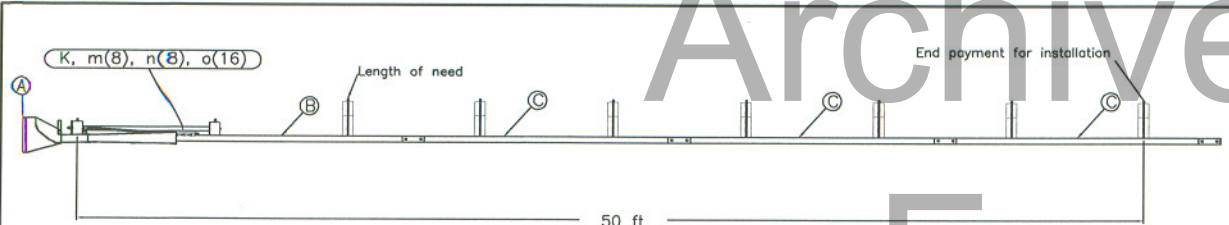

- GENERAL NOTES:
1. Breakaway posts are required with the SKT.
  2. All bolts, nuts, cable assemblies, cable anchors and bearing plates shall be galvanized.
  3. The SKT can be flared at a rate of up to 25:1 to prevent the impact head from encroaching on the shoulder.
  4. The foundation tubes shall not protrude more than 4" above the ground (measured along a 5' cord). Site grading may be necessary to meet this requirement.
  5. When rock is encountered, a 12" Ø post hole, 20" into the rock surface may be used if approved by the engineer. Granular material will be placed in the bottom of the hole, approximately 2.5" deep to provide drainage. The soil tubes can be field cut to length, placed in the hole and backfilled with adequately compacted material excavated from the hole.
  6. The breakaway cable assembly must be taut. A locking device (vice grips or channel lock pliers) should be used to prevent the cable from twisting when tightening nuts.
  7. A site evaluation should be considered if there is less than 25' between the outlet side of the terminal and any adjacent driving lane.
  8. The soil tubes may be driven with an approved driving head. They shall not be driven with the post in the tube.
  9. The wood blockouts should be "toe-nailed" to the rectangular wood posts to prevent them from turning when the wood shrinks.

ITEM	QTY	BILL OF MATERIALS	ITEM NO.
A	1	IMPACT HEAD	S3000
B	1	W-BEAM GUARDRAIL END SECTION, 12 Ga.	S1303 MGS
C	3	W-BEAM GUARDRAIL, 12 Ga.	G1203 MGS
D	2	FOUNDATION TUBE	E730/S730
E	2	UNIVERSAL BCT WOOD POST	UP650
F	1	GROUND STRUT	E780
G	6	UNIVERSAL CRT WOOD POST	UP671
H	1	BEARING PLATE	E750
J	1	PIPE SLEEVE	E740
K	1	CABLE ANCHOR BOX	S760
L	1	BCT CABLE ANCHOR ASSEMBLY	E770
M	6	MGS TIMBER BLOCKOUT OR EQUIV.	P677
HARDWARE (ALL DIMENSIONS IN INCHES)			
a	24	5/8" x 1 1/4" SPLICE BOLT	B580122
b	2	5/8" x 8 HEX BOLT	B580804
c	2	5/8" x 10 HEX BOLT	B581004
d	1	5/8" x 10 H.G.R. BOLT	B581002
e	6	5/8" x 22 H.G.R. BOLT	B582202
f	35	5/8" H.G.R. NUT	N050
g	7	H.G.R. WASHER	W050
h	2	1 ANCHOR CABLE HEX NUT	N100
j	2	1 ANCHOR CABLE WASHER	W100
k	2	3/8" x 3 LAG SCREW	E350
m	8	CABLE ANCHOR BOX SHOULDER BOLT	S858A
n	8	1/2" A325 STRUCTURAL NUT	N055A
o	16	1 1/16" OD x 9/16" ID A325 STR. WASHER	W050A

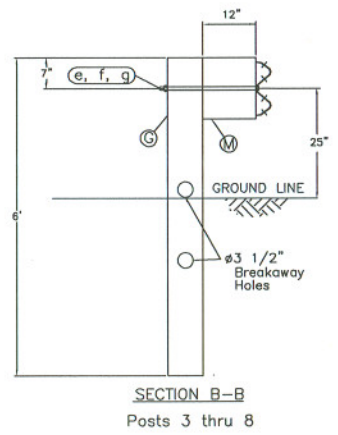
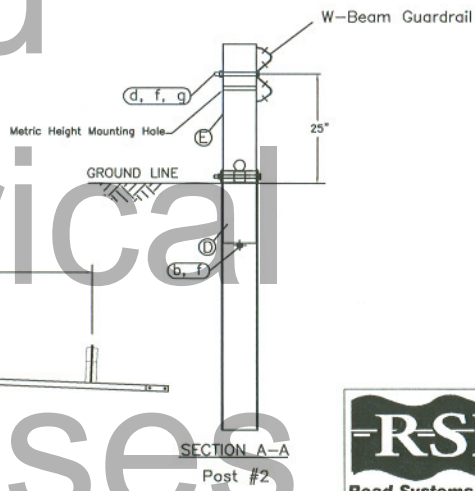

Big Spring, TX  
Phone: 432-263-2435  
or Phone: 338-346-0721

Sequential Kinking Terminal  
Midwest Guardrail System  
Universal Wood Posts

Sheet: **1**

Date: 04/24/2008

Drawing Name: SKT-MGS-W UP Scale: NONE

By: JRR

Archived For Research and Historical Purposes Only

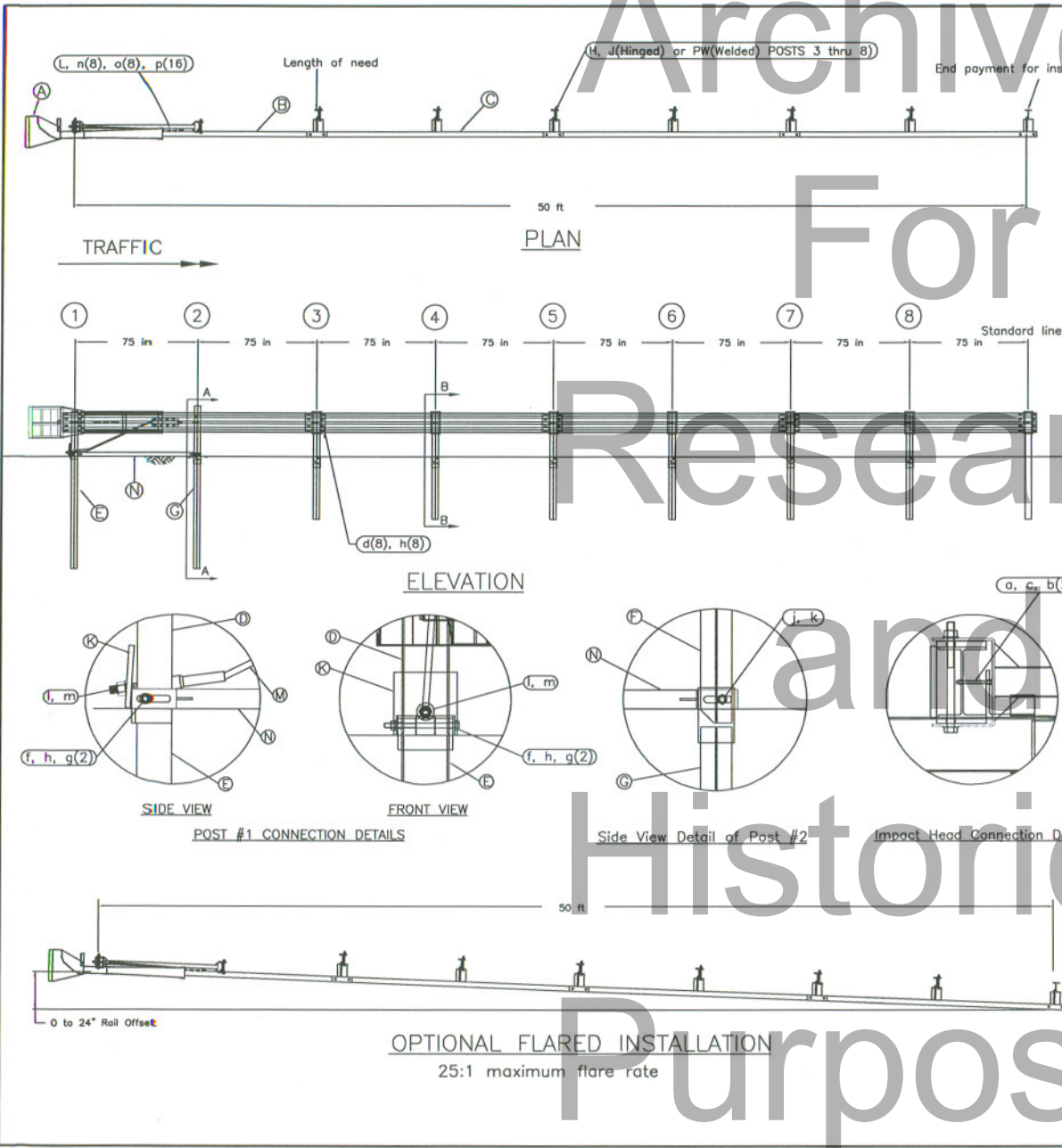

- GENERAL NOTES:**
1. Breakaway posts are required with the SKT.
  2. All bolts, nuts, cable assemblies, cable anchors and bearing plates shall be galvanized.
  3. The SKT can be flared at a rate of up to 25:1 to prevent the impact head from encroaching on the shoulder.
  4. The lower sections of the posts shall not protrude more than 4" above the ground (measured along a 5' cord). Site grading may be necessary to meet this requirement.
  5. The lower section of the hinged posts should not be driven with the upper post attached. If the post is placed in a drilled hole, the backfill material must be satisfactorily compacted to prevent settlement.
  6. When rock is encountered, a 10" Ø post hole, 20" into the rock surface may be used if approved by the engineer. Granular material will be placed in the bottom of the hole, approximately 2.5" deep to provide drainage. Posts 1 & 2 can be field cut to length, placed in the hole and backfilled with adequately compacted material excavated from the hole.
  7. The breakaway cable assembly must be taut. A locking device (vice grips or channel lock pliers) should be used to prevent the cable from twisting when tightening nuts.
  8. A site evaluation should be considered if there is less than 25' between the outlet side of the terminal and any adjacent driving lane.

ITEM QTY	BILL OF MATERIALS	ITEM NO.
A 1	IMPACT HEAD	S3000
B 1	W-BEAM GUARDRAIL END SECTION, 12 Ga.	S1303/5
C 3/1	W-BEAM GUARDRAIL, 12 Ga.	G1203/5
D 1	FIRST POST ASSEMBLY TOP	UHP1A
E 1	FIRST POST ASSEMBLY BOTTOM	HP1B
F 1	SECOND POST ASSEMBLY TOP	UHP2A
G 1	SECOND POST ASSEMBLY BOTTOM	HP2B
K 1	BEARING PLATE	E750
L 1	CABLE ANCHOR BOX	S760
M 1	BCT CABLE ANCHOR ASSEMBLY	E770
N 1	GROUND STRUT HINGED POST	S785
O 6	ROUTED TIMBER BLOCKOUT/RECYC. EQUIV.	P616

HARDWARE (ALL DIMENSIONS IN INCHES)		
a 2	1/4 x 4 HEX BOLT GRD 5	B140404A
b 4	1/4 WASHER	W014
c 2	1/4 HEX NUT	N014
d 25/17	5/8 Dia. x 1 1/4 SPLICE BOLT, POST #2	B580122
e 6	5/8 Dia. x 10 H.G.R. BOLT (POSTS 3 THRU 8)	B581002
f 1	5/8 Dia. x 9 HEX BOLT GRD 5	B580904A
g 9	5/8 WASHER	W050
h 32/24	5/8 Dia. H.G.R NUT	N050
i 2	1 ANCHOR CABLE HEX NUT	N100
m 2	1 ANCHOR CABLE WASHER	W100
n 8	CABLE ANCHOR BOX SHOULDER BOLT	SB58A
o 8	1/2 A325 STRUCTURAL NUT	N055A
p 16	1 1/16 OD x 9/16 ID A325 STR. WASHER	W050A

WELDED POST QUANTITIES		
*PW 6	WELDED BREAKAWAY POST	JPB621
*j 1	3/4 Dia. x 8 1/2 HEX BOLT GRD 5	B340854A
*k 1	3/4 Dia. HEX NUT	N030

  

HINGED POST QUANTITIES		
*H 6	BREAKAWAY LINE POST TOP	UHP3A
*J 6	BREAKAWAY LINE POST BOTTOM	UHP3B
*j 7	3/4 Dia. x 8 1/2 HEX BOLT GRD 5	B340854A
*k 7	3/4 Dia. HEX NUT	N030

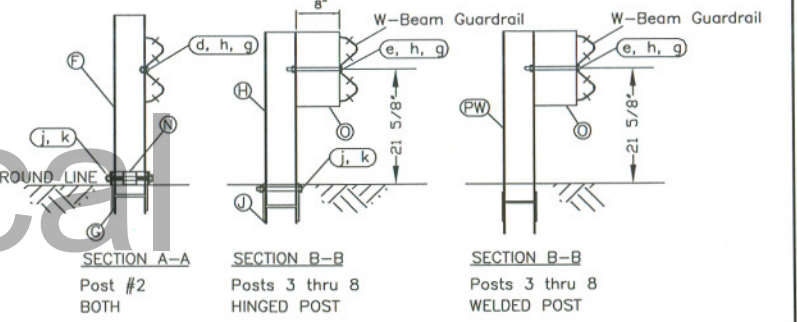

 <b>Road Systems, Inc.</b> <small>Big Spring, TX Phone: 432-363-9435 or Phone: 330-346-0721</small>	<b>Sequential Kinking Terminal SKT Metric Height Steel Post System Hinged and Welded Options</b>	Sheet: <b>1</b> Date: 04/29/2008 By: JRR Rev:
	Drawing Name: SKT-M-S-UP	Scale: NONE

Archived  
For  
Research  
and  
Historical  
Purposes  
Only

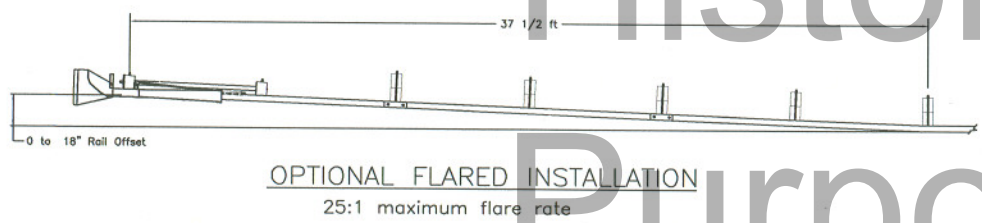
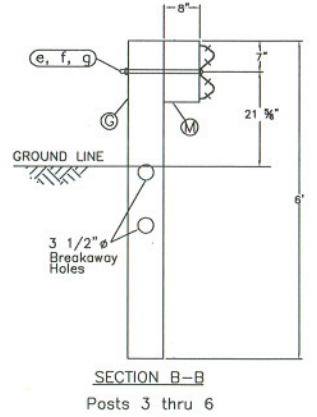
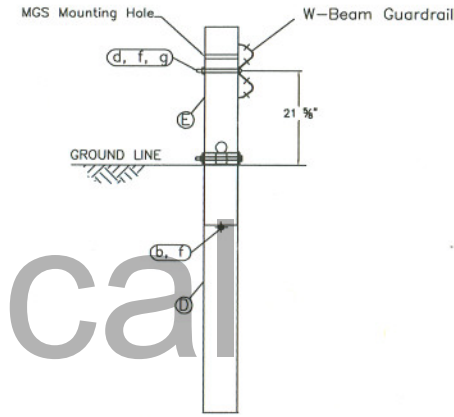
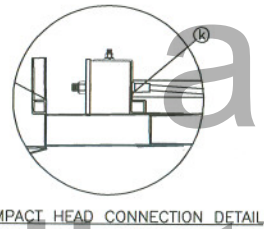
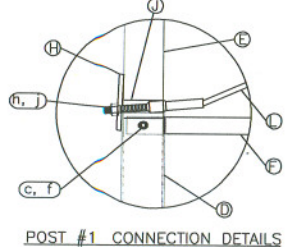
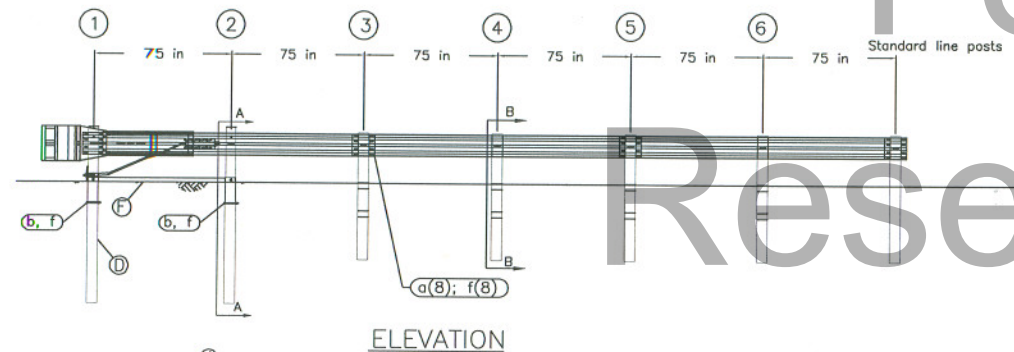
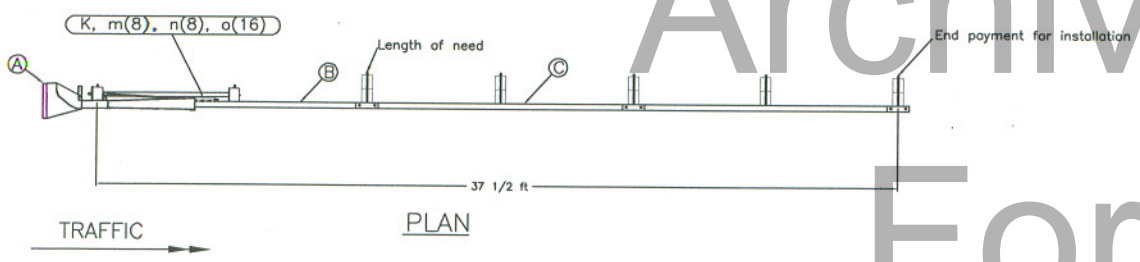

- GENERAL NOTES:**
1. Breakaway posts are required with the SKT.
  2. All bolts, nuts, cable assemblies, cable anchors and bearing plates shall be galvanized.
  3. The SKT can be flared at a rate of up to 25:1 to prevent the impact head from encroaching on the shoulder.
  4. The foundation tubes shall not protrude more than 4" above the ground (measured along a 5' cord). Site grading may be necessary to meet this requirement.
  5. When rock is encountered, a 12" Ø post hole, 20" into the rock surface may be used if approved by the engineer. Granular material will be placed in the bottom of the hole, approximately 2.5" deep to provide drainage. The soil tubes can be field cut to length, placed in the hole and backfilled with adequately compacted material excavated from the hole.
  6. The breakaway cable assembly must be taut. A locking device (vice grips or channel lock pliers) should be used to prevent the cable from twisting when tightening nuts.
  7. A site evaluation should be considered if there is less than 25' between the outlet side of the terminal and any adjacent driving lane.
  8. The soil tubes may be driven with an approved driving head. They shall not be driven with the post in the tube.
  9. The wood blockouts should be "toe-nailed" to the rectangular wood posts to prevent them from turning when the wood shrinks.

ITEM	QTY	BILL OF MATERIALS	ITEM NO.
A	1	IMPACT HEAD	S3000
B	1	W-BEAM GUARDRAIL END SECTION, 12 Ga.	S1303/5
C	2/1	W-BEAM GUARDRAIL, 12 Ga.	G1203
D	2	FOUNDATION TUBE	E730/S730
E	2	UNIVERSAL BCT WOOD POST	UP650
F	1	GROUND STRUT	E780
G	4	UNIVERSAL CRT WOOD POST	UP671
H	1	BEARING PLATE	E750
J	1	PIPE SLEEVE	E740
K	1	CABLE ANCHOR BOX	S760
L	1	BCT CABLE ANCHOR ASSEMBLY	E770
M	4	6"x8" TIMBER BLOCKOUT OR EQUIV.	P675

HARDWARE (ALL DIMENSIONS IN INCHES)			
a	16/8	5/8" x 1 1/4" SPLICE BOLT	B580122
b	2	5/8" x 8 HEX BOLT	B580804
c	2	5/8" x 10 HEX BOLT	B581004
d	1	5/8" x 10 H.G.R. BOLT	B581002
e	4	5/8" x 18 H.G.R. BOLT	B581802
f	25/17	5/8" H.G.R. NUT	N050
g	5	H.G.R. WASHER	W050
h	2	1 ANCHOR CABLE HEX NUT	N100
j	2	1 ANCHOR CABLE WASHER	W100
k	2	3/8 x 3 LAG SCREW	E350
m	8	CABLE ANCHOR BOX SHOULDER BOLT	SB58A
n	8	1/2 A325 STRUCTURAL NUT	N055A
o	16	1 1/16 OD x 9/16 ID A325 STR. WASHER	W050A

Big Spring, TX  
Phone: 432-263-2435  
or Phone: 330-346-0721

**Sequential Kinking Terminal  
SKT-LITE Metric Height  
Universal Wood Posts**

Drawing Name: SKT-M-LITE-W UP      Scale: NONE

Sheet: **1**

Date: 04/24/2008

By: JRR      Rec: [Signature]

TRAFFIC



**RSI**  
 Road Systems, Inc.  
 Big Spring, TX  
 Phone: 432-263-2435  
 or Phone: 330-346-0721

Universal Hinge Post  
 Comparison

Drawing Name:  
 UHP3 Height Comparison

Scale:  
 NONE

Sheet:  
**1**  
 Date:  
 04/01/08  
 By:  
 JRR  
 Rev:

Archived  
 For  
 Research  
 and  
 Historical  
 Purposes  
 Only

Archived  
For  
Research  
and  
Historical  
Purposes  
Only

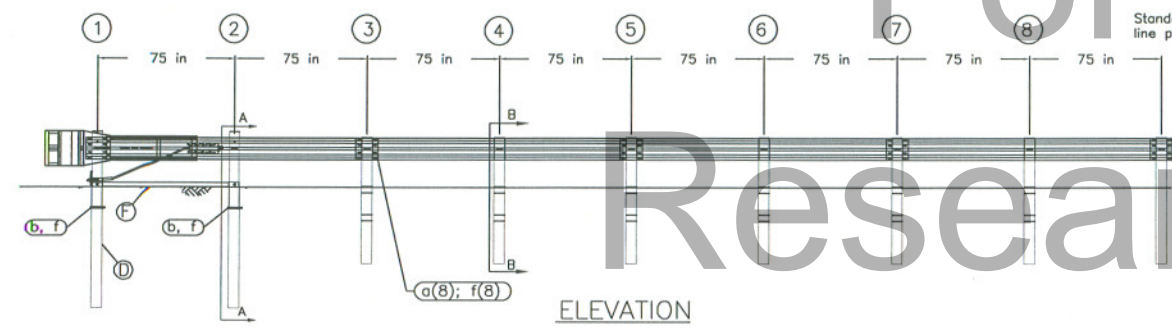
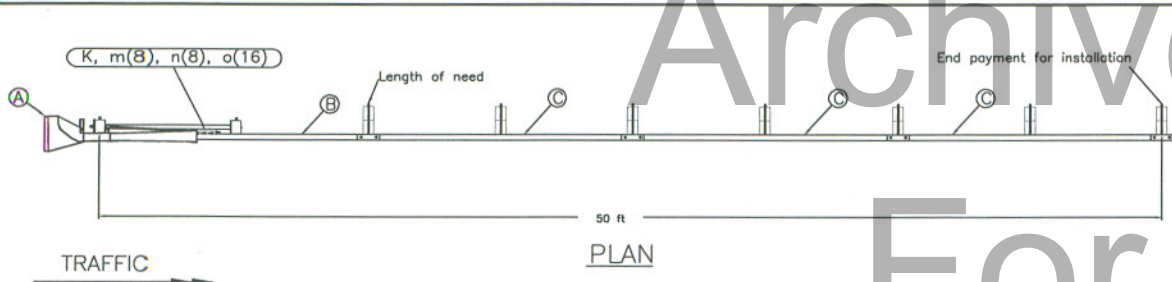

- GENERAL NOTES:**
1. Breakaway posts are required with the SKT.
  2. All bolts, nuts, cable assemblies, cable anchors and bearing plates shall be galvanized.
  3. The SKT can be flared at a rate of up to 25:1 to prevent the impact head from encroaching on the shoulder.
  4. The foundation tubes shall not protrude more than 4" above the ground (measured along a 5' cord). Site grading may be necessary to meet this requirement.
  5. When rock is encountered, a 12" Ø post hole, 20" into the rock surface may be used if approved by the engineer. Granular material will be placed in the bottom of the hole, approximately 2.5" deep to provide drainage. The soil tubes can be field cut to length, placed in the hole and backfilled with adequately compacted material excavated from the hole.
  6. The breakaway cable assembly must be taut. A locking device (vice grips or channel lock pliers) should be used to prevent the cable from twisting when tightening nuts.
  7. A site evaluation should be considered if there is less than 25' between the outlet side of the terminal and any adjacent driving lane.
  8. The soil tubes may be driven with an approved driving head. They shall not be driven with the post in the tube.
  9. The wood blockouts should be "toe-nailed" to the rectangular wood posts to prevent them from turning when the wood shrinks.

ITEM	QTY	BILL OF MATERIALS	ITEM NO.
A	1	IMPACT HEAD	S3000
B	1	W-BEAM GUARDRAIL END SECTION, 12 Ga.	S1303/5
C	3/1	W-BEAM GUARDRAIL, 12 Ga.	G1203/5
D	2	FOUNDATION TUBE	E730/S730
E	2	UNIVERSAL BCT WOOD POST	UP650
F	1	GROUND STRUT	E780
G	6	UNIVERSAL CRT WOOD POST	UP671
H	1	BEARING PLATE	E750
J	1	PIPE SLEEVE	E740
K	1	CABLE ANCHOR BOX	S760
L	1	BCT CABLE ANCHOR ASSEMBLY	E770
M	6	6"x8" TIMBER BLOCKOUT OR EQUIV.	P675
HARDWARE (ALL DIMENSIONS IN INCHES)			
a	24/16	5/8" x 1 1/4" SPLICE BOLT	B580122
b	2	5/8" x 8 HEX BOLT	B580804
c	2	5/8" x 10 HEX BOLT	B581004
d	1	5/8" x 10 H.G.R. BOLT	B581002
e	6	5/8" x 18 H.G.R. BOLT	B581802
f	35/27	5/8" H.G.R. NUT	N050
g	7	H.G.R. WASHER	W050
h	2	1 ANCHOR CABLE HEX NUT	N100
j	2	1 ANCHOR CABLE WASHER	W100
k	2	3/8" x 3 LAG SCREW	E350
m	8	CABLE ANCHOR BOX SHOULDER BOLT	SB58A
n	8	1/2" A325 STRUCTURAL NUT	N055A
o	16	1 1/16" OD x 9/16" ID A325 STR. WASHER	W050A

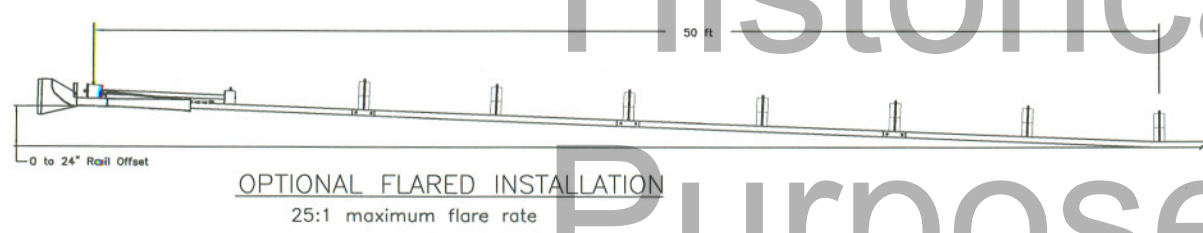
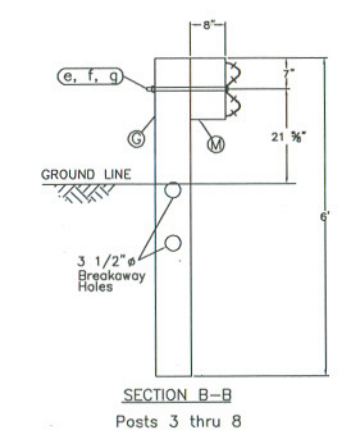
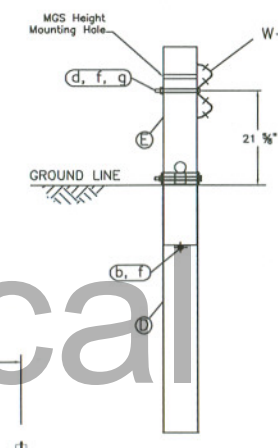
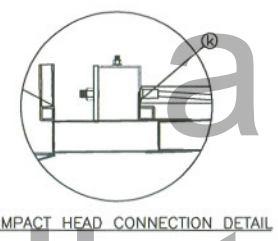
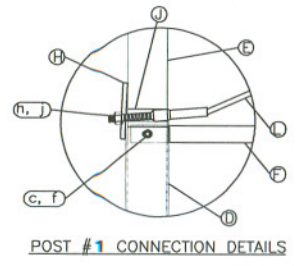

<p><b>Road Systems, Inc.</b></p> <p>Big Spring, TX Phone: 432-263-2435 or Phone: 330-346-0721</p>	<p>Sequential Kinking Terminal SKT Metric Height Universal Wood Posts</p>	<p>Sheet:</p> <p><b>1</b></p>
	<p>Drawing Name:</p> <p>SKT-M-W-UP</p>	<p>Scale:</p> <p>NONE</p>



Archived  
For  
Research  
and  
Historical  
Purposes  
Only

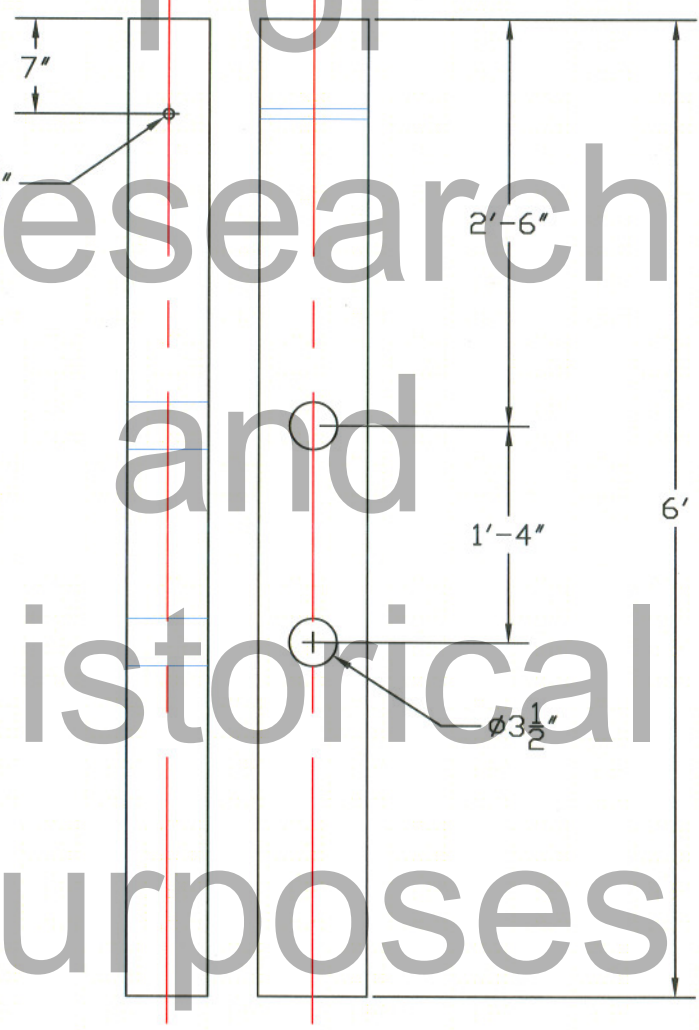

NOTE:  
All holes locations  
should reference the  
bottom of the post.

NOTE:  
All hole locations  
should reference the  
top of the post.



UNIVERSAL CRT  
POST

Sheet:	1
Date:	04/24/2008
By:	JRR
Rev:	
Scale:	NONE
Drawing Name:	UP671