



U.S. Department
of Transportation
**Federal Highway
Administration**

Office of the Administrator

1200 New Jersey Ave., SE
Washington, D.C. 20590

July 9, 2012

In Reply Refer To:
HSST B-235

Mr. Vue Her
Transportation Engineer
Office of Roadside Safety and Cooperative Research
Division of Research and Innovation
California Department of Transportation
5900 Folsom Blvd., MS-5
Sacramento, California 95819

Dear Mr. Her:

This letter is in response to your request for the Federal Highway Administration (FHWA) to review a roadside safety system for eligibility for reimbursement under the Federal-aid highway program.

Name of system:	California Department of Transportation (CalTrans) Low-Profile Reinforced Concrete Barrier
Type of system:	Permanent Longitudinal Barrier
Test Level:	NCHRP 350 Test Level 2 (TL-2)
Testing conducted by:	CalTrans Roadside Safety Research Group
Task Force 13 Designator:	SGR45
Date of request:	November 16, 2010
Date initially acknowledged:	November 16, 2010
Date of completed package:	May 1, 2012

Decision

The following device is eligible, with details provided as attached as an integral part of this letter:

- CalTrans TL-2 Low-Profile Reinforced Concrete Barrier

Based on a review of crash test results submitted by the manufacturer certifying the device described herein meets the crashworthiness criteria of the National Cooperative Highway Research Program (NCHRP) Report 350, the device is eligible for reimbursement under the Federal-aid highway program. Eligibility for reimbursement under the Federal-aid highway program does not establish approval or endorsement by the FHWA for any particular purpose or use.

The FHWA, the Department of Transportation, and the United States Government do not endorse products or services and the issuance of a reimbursement eligibility letter is not an endorsement of any product or service.

Requirements

To be found eligible for Federal-aid funding, roadside safety devices should meet the crash test and evaluation criteria contained in the National Cooperative Highway Research Program (NCHRP) Report 350 or the American Association of State Highway and Transportation Officials' Manual for Assessing Safety Hardware (MASH).

Description

The low-profile barrier test article was constructed at the Caltrans Dynamic Test Facility. The test article was 30.48 m (100 feet) long with a nominal height of 0.4572 m (18 inches). It consisted of a 0.305 m (12 inch) deep foundation, a 0.105 m (6 inch) curb, with nine 0.305 m (12 inch) posts spaced at 3.048 m (10 feet) on center, and a 3x8x3/8 inch structural steel rail. Because existing soils were non-homogeneous due to an assortment of previous projects at the construction location, a 2.44 x 0.61 x 30.48 meter (8 x 2 x 100 feet) soil bed was excavated then backfilled with soil from a local gravel provider. The soil analysis of the fill soil was completed by the Caltrans Geotechnical Lab and classified as fine sandy silt. At a 90% relative compaction and an optimum moisture content of 12.3%, the maximum dry density was 114.6 pcf. Upon completion of the excavation, the bed was filled with soil, 0.1016 meters to 0.1524 meters (4inches to 6inches) per lift. Each lift was moisture-conditioned and compacted using a vibratory roller. After the bed was completely filled and compacted, a nuclear gauge was used to test the compaction. The minimum relative compaction required was 90% under Caltrans 2006 Standard Specifications. A 93% relative compaction was achieved with a density of 122.4 pcf. The low-profile barrier was constructed and installed in two phases: pouring of the footing and attachment of the rail. The soil was re-excavated 1.016 meters x 0.3048 meter x 30.48 meters (3.3 feet x 1 foot x 100 feet) to install the footing of the barrier. The footing and the curb were constructed in one pour.

The footing was 30.48 m (100 feet) long and had 9 posts spaced 3.048 m (10 feet) on center. The rail came in 4 pieces and spanned 30.48 m (100 feet).

Once the formwork for the footing was complete, the reinforcing steel and anchor bolts were positioned and tied in. Concrete was then poured into the formwork while being consolidated with a concrete vibrator. All exposed steel components were galvanized from the manufacturer prior to installation. The footing was placed on December 4, 2009. The posts and rails were installed on December 15, 2009. Because of the timing of the pour and when staff was available to test the compressive strength of the concrete, the 28-day test could not be conducted. Instead, the compressive strength was tested at 31 days and was determined to be 40.6 MPa (5890 psi).

The adjacent pavement elevation varied along the length of the low-profile barrier. Thus the height of the barrier ranged from 0.4572 to 0.4826 meters (18 inches to 19 inches).

Design details are provided as enclosure to this correspondence.

Summary and Standard Provisions

The low-profile barrier was crashed test in accordance with NCHRP Report 350 evaluation criteria.

Test 701 was tested at NCHRP Test Level 2 (Test 2-11). The vehicle tracked smoothly into the barrier, impacting 400 millimeters (15.75 inches) downstream of the 5th barrier post. The front tire (red) made contact with the sleeve of the rail 530 millimeters (20.8 inches) downstream of

the center of the post. The rear tire (green) made contact 1430 millimeters (56.3 inches) downstream of the post. The vehicle lost contact with the barrier at 0.412 seconds after impact. The impact speed and angle were 70.2 km/h and 25.3°, respectively. The exit speed and angle were 62.3 km/h and 7.8°, respectively. The vehicle remained upright during and after the impact and vehicle stability was considered satisfactory. Occupant risk factors satisfied the test criteria and the vehicle exit trajectory remained within acceptable limits.

Findings

Test 702 was performed at NCHRP Report 350 Test Level 2 (2-10). The vehicle tracked smoothly into the barrier. The front tire (red) made contact 1260 millimeters (49.6 inches) upstream of the 3rd barrier post. The rear tire (green) made contact 630 millimeters (24.8 inches) downstream of the post. The vehicle lost contact with the barrier at 0.364 seconds after impact. The impact speed and angle were 70.8 km/h and 21°, respectively. The exit speed and angle were 63.1 km/h and 9.6°. The vehicle remained upright during and after the impact and vehicle stability was considered satisfactory. Occupant risk factors satisfied the test criteria and the vehicle exit trajectory remained within acceptable limits.

Therefore, the system described and detailed in the attached form is eligible for reimbursement and may be installed under the range of conditions tested.

Please note the following standard provisions that apply to FHWA eligibility letters:

- This letter provides a AASHTO/ARTBA/AGC Task Force 13 designator that should be used for the purpose of the creation of a new and/or the update of existing Task Force 13 drawing for posting on the on-line 'Guide to Standardized Highway Barrier Hardware' currently referenced in AASHTO Roadside Design Guide.
- This finding of eligibility does not cover other structural features of the systems, nor conformity with the Manual on Uniform Traffic Control Devices.
- Any changes that may influence system conformance with NCHRP Report 350 criteria will require a new reimbursement eligibility letter.
- Should the FHWA discover that the qualification testing was flawed, that in-service performance reveals safety problems, or that the system is significantly different from the version that was crash tested, we reserve the right to modify or revoke this letter.
- You are expected to supply potential users with sufficient information on design and installation requirements to ensure proper performance.
- You are expected to certify to potential users that the hardware furnished has the same chemistry, mechanical properties, and geometry as that submitted for review, and that it will meet the crash test and evaluation criteria of the NCHRP Report 350.
- To prevent misunderstanding by others, this letter of eligibility is designated as number B-235 and shall not be reproduced except in full. This letter and the test documentation

- This letter shall not be construed as authorization or consent by the FHWA to use, manufacture, or sell any patented system for which the applicant is not the patent holder. The FHWA does not become involved in issues concerning patent law. Patent issues, if any, are to be resolved by the applicant.
- CalTrans Low-Profile Reinforced Concrete Barrier is considered a generic barrier

Sincerely yours,



Michael S. Griffith

Director, Office of Safety Technologies

Office of Safety

Enclosures

Archived
For
Research
and
Historical
Purposes
Only

Figure 3-8. Test 701 Data Summary Sheet

Overhead Camera 1



t = 0.0 sec

t = 0.10 sec

t = 0.20 sec

t = 0.30 sec

Overhead Camera 2



t = 0.30 sec

t = 0.40 sec

t = 0.50 sec

t = 0.60 sec

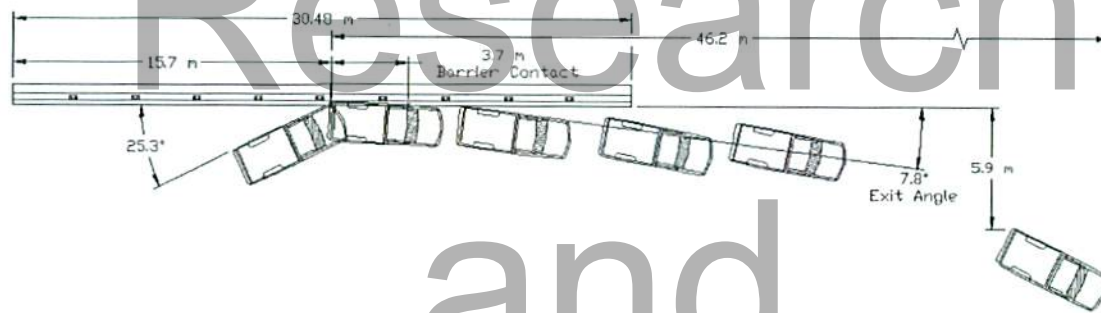

Test Barrier:

Type: Longitudinal Barrier (Low-Profile)
 Length: 30.48 m (100 ft)

Test Date:

August 12, 2010

Test Vehicle:

Model: 1990 GMC Sierra 2500 2WD Pickup
 Inertial mass: 1960.5 kg

Test Dummy:

Type: none used
 Weight/Position: N/A

Impact/Exit Conditions:

Impact/Exit Velocity: 70.2 km/h / 62.3 km/h
 Impact/Exit Angle: 25.3° / 7.8°
 Impact Severity: 68.1 kJ

Test Data:

Occ. Impact Velocity (Long/Lat): 3.6 m/s / -5.6 m/s
 Ridedown Acceleration (Long/Lat): -4.6 g / 8.7 g
 ASI: 1.01
 Exterior (VDS/CDC): FL-3, LD-1 / 10LFEW9
 Interior (OCDI): LF0002000
 Max. Roll/Pitch/Yaw Angles: -45.3° / -6.5° / 50.7°

Barrier Damage:

The deflection of the rail and footing was 9.823 mm and 0.408 mm. Damage to the barrier was minimal and considered cosmetic.

Figure 3-16. Test 702 Data Summary Sheet

Overhead Camera 1



t = 0.0 sec t = 0.10 sec t = 0.20 sec t = 0.30 sec

Overhead Camera 2



t = 0.40 sec t = 0.50 sec t = 0.60 sec t = 0.70 sec



Test Barrier:

Type: Longitudinal Barrier (Low-Profile)
 Length: 30.48 m (100 ft)

Test Date:

June 8, 2011

Test Vehicle:

Model: 1995 Geo Metro
 Inertial mass: 832 kg

Test Dummy:

Type: Hybrid III
 Weight/Position: 75 kg/ Front Left (lap & shoulder belt)

Impact/Exit Conditions:

Impact/Exit Velocity: 70.8 km/h / 63.1 km/h
 Impact/Exit Angle: 21.0° / 9.6°
 Impact Severity: 20.7 kJ

Test Data:

Occ. Impact Velocity (Long/Lat): 3.1 m/s / -6.6 m/s
 Ridedown Acceleration (Long/Lat): -2.8 g / 8.0 g
 ASI: 1.60
 Exterior (VDS/CDC): FL-1, LFQ-2, LD-1 / 10LFEW9
 Interior (OCDI): LF0000000
 Max. Roll/Pitch/Yaw Angles: -18.7° / -11.6° / 67.6°

Barrier Damage:

There was no discernable permanent deflection of the footing or rail.

DIST.	COUNTY	ROUTE	POSTMILE LOCAL CENSUS	SHEET NO.	TOTAL SHEETS
				2	5



REGISTERED ENGINEER - CIVIL
 PLUS APPROVAL DATE FOR THIS PROJECT
 THIS SEAL IS VALID ONLY FOR THE SIGNATURE OF THE ENGINEER
 AND IS NOT VALID FOR ANY OTHER PURPOSES
 CONTRACTORS OF REGISTERED STATUS OF THIS STATE

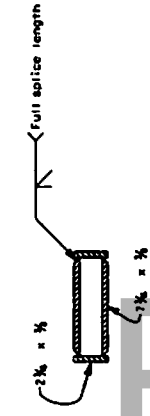

SECTION SLEEVE

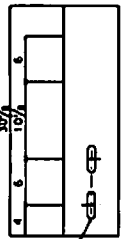

1" x 3/4" Slotted Hole Typ, top and bottom

EXPANSION SLEEVE DETAIL (TOP VIEW)

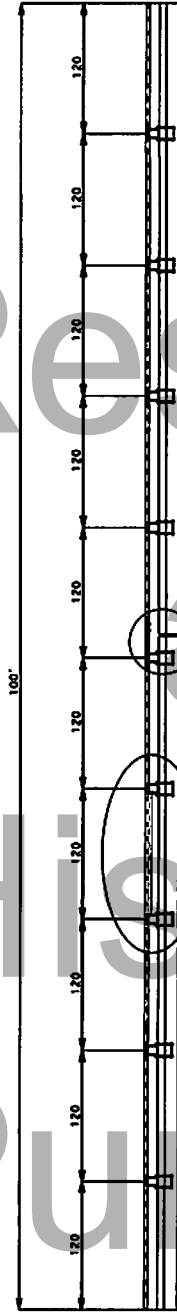

LPB ELEVATION

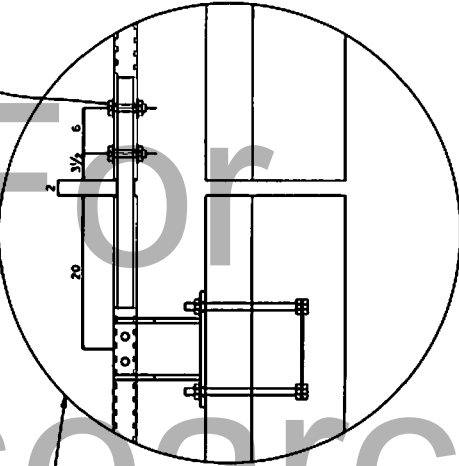

EXPANSION SPLICE

Use 5/8" x 5/16" MS Bolts with washers, fully tensioned. 1" holes in rail typ

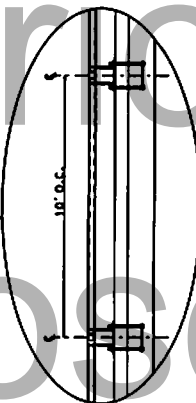

ELEVATION OF RAIL POST SPACING

NO SCALE
 ALL DIMENSIONS ARE IN INCHES UNLESS OTHERWISE SHOWN

LOW-PROFILE BARRIER
 LOCATION MAP AND GENERAL PLAN

OFFICE OF RESEARCH AND INNOVATION
 ROADSIDE SAFETY RESEARCH GROUP

STATE OF CALIFORNIA
 DEPARTMENT OF TRANSPORTATION

DATE	BY	REVISION
DETAILS	SCALE	PIECES
QUANTITIES		

RELATIVE BORDER SCALE
 0 1 2 3
 15' IN INCHES
 ... (V) ... (H) ... (D) ... (S) ... (L) ... (P) ... (R) ... (T) ... (U) ... (V) ... (W) ... (X) ... (Y) ... (Z) ... (AA) ... (AB) ... (AC) ... (AD) ... (AE) ... (AF) ... (AG) ... (AH) ... (AI) ... (AJ) ... (AK) ... (AL) ... (AM) ... (AN) ... (AO) ... (AP) ... (AQ) ... (AR) ... (AS) ... (AT) ... (AU) ... (AV) ... (AW) ... (AX) ... (AY) ... (AZ) ... (BA) ... (BB) ... (BC) ... (BD) ... (BE) ... (BF) ... (BG) ... (BH) ... (BI) ... (BJ) ... (BK) ... (BL) ... (BM) ... (BN) ... (BO) ... (BP) ... (BQ) ... (BR) ... (BS) ... (BT) ... (BU) ... (BV) ... (BW) ... (BX) ... (BY) ... (BZ) ... (CA) ... (CB) ... (CC) ... (CD) ... (CE) ... (CF) ... (CG) ... (CH) ... (CI) ... (CJ) ... (CK) ... (CL) ... (CM) ... (CN) ... (CO) ... (CP) ... (CQ) ... (CR) ... (CS) ... (CT) ... (CU) ... (CV) ... (CW) ... (CX) ... (CY) ... (CZ) ... (DA) ... (DB) ... (DC) ... (DD) ... (DE) ... (DF) ... (DG) ... (DH) ... (DI) ... (DJ) ... (DK) ... (DL) ... (DM) ... (DN) ... (DO) ... (DP) ... (DQ) ... (DR) ... (DS) ... (DT) ... (DU) ... (DV) ... (DW) ... (DX) ... (DY) ... (DZ) ... (EA) ... (EB) ... (EC) ... (ED) ... (EE) ... (EF) ... (EG) ... (EH) ... (EI) ... (EJ) ... (EK) ... (EL) ... (EM) ... (EN) ... (EO) ... (EP) ... (EQ) ... (ER) ... (ES) ... (ET) ... (EU) ... (EV) ... (EW) ... (EX) ... (EY) ... (EZ) ... (FA) ... (FB) ... (FC) ... (FD) ... (FE) ... (FF) ... (FG) ... (FH) ... (FI) ... (FJ) ... (FK) ... (FL) ... (FM) ... (FN) ... (FO) ... (FP) ... (FQ) ... (FR) ... (FS) ... (FT) ... (FU) ... (FV) ... (FW) ... (FX) ... (FY) ... (FZ) ... (GA) ... (GB) ... (GC) ... (GD) ... (GE) ... (GF) ... (GG) ... (GH) ... (GI) ... (GJ) ... (GK) ... (GL) ... (GM) ... (GN) ... (GO) ... (GP) ... (GQ) ... (GR) ... (GS) ... (GT) ... (GU) ... (GV) ... (GW) ... (GX) ... (GY) ... (GZ) ... (HA) ... (HB) ... (HC) ... (HD) ... (HE) ... (HF) ... (HG) ... (HH) ... (HI) ... (HJ) ... (HK) ... (HL) ... (HM) ... (HN) ... (HO) ... (HP) ... (HQ) ... (HR) ... (HS) ... (HT) ... (HU) ... (HV) ... (HW) ... (HX) ... (HY) ... (HZ) ... (IA) ... (IB) ... (IC) ... (ID) ... (IE) ... (IF) ... (IG) ... (IH) ... (II) ... (IJ) ... (IK) ... (IL) ... (IM) ... (IN) ... (IO) ... (IP) ... (IQ) ... (IR) ... (IS) ... (IT) ... (IU) ... (IV) ... (IW) ... (IX) ... (IY) ... (IZ) ... (JA) ... (JB) ... (JC) ... (JD) ... (JE) ... (JF) ... (JG) ... (JH) ... (JI) ... (JJ) ... (JK) ... (JL) ... (JM) ... (JN) ... (JO) ... (JP) ... (JQ) ... (JR) ... (JS) ... (JT) ... (JU) ... (JV) ... (JW) ... (JX) ... (JY) ... (JZ) ... (KA) ... (KB) ... (KC) ... (KD) ... (KE) ... (KF) ... (KG) ... (KH) ... (KI) ... (KJ) ... (KK) ... (KL) ... (KM) ... (KN) ... (KO) ... (KP) ... (KQ) ... (KR) ... (KS) ... (KT) ... (KU) ... (KV) ... (KW) ... (KX) ... (KY) ... (KZ) ... (LA) ... (LB) ... (LC) ... (LD) ... (LE) ... (LF) ... (LG) ... (LH) ... (LI) ... (LJ) ... (LK) ... (LL) ... (LM) ... (LN) ... (LO) ... (LP) ... (LQ) ... (LR) ... (LS) ... (LT) ... (LU) ... (LV) ... (LW) ... (LX) ... (LY) ... (LZ) ... (MA) ... (MB) ... (MC) ... (MD) ... (ME) ... (MF) ... (MG) ... (MH) ... (MI) ... (MJ) ... (MK) ... (ML) ... (MM) ... (MN) ... (MO) ... (MP) ... (MQ) ... (MR) ... (MS) ... (MT) ... (MU) ... (MV) ... (MW) ... (MX) ... (MY) ... (MZ) ... (NA) ... (NB) ... (NC) ... (ND) ... (NE) ... (NF) ... (NG) ... (NH) ... (NI) ... (NJ) ... (NK) ... (NL) ... (NM) ... (NN) ... (NO) ... (NP) ... (NQ) ... (NR) ... (NS) ... (NT) ... (NU) ... (NV) ... (NW) ... (NX) ... (NY) ... (NZ) ... (OA) ... (OB) ... (OC) ... (OD) ... (OE) ... (OF) ... (OG) ... (OH) ... (OI) ... (OJ) ... (OK) ... (OL) ... (OM) ... (ON) ... (OO) ... (OP) ... (OQ) ... (OR) ... (OS) ... (OT) ... (OU) ... (OV) ... (OW) ... (OX) ... (OY) ... (OZ) ... (PA) ... (PB) ... (PC) ... (PD) ... (PE) ... (PF) ... (PG) ... (PH) ... (PI) ... (PJ) ... (PK) ... (PL) ... (PM) ... (PN) ... (PO) ... (PP) ... (PQ) ... (PR) ... (PS) ... (PT) ... (PU) ... (PV) ... (PW) ... (PX) ... (PY) ... (PZ) ... (QA) ... (QB) ... (QC) ... (QD) ... (QE) ... (QF) ... (QG) ... (QH) ... (QI) ... (QJ) ... (QK) ... (QL) ... (QM) ... (QN) ... (QO) ... (QP) ... (QQ) ... (QR) ... (QS) ... (QT) ... (QU) ... (QV) ... (QW) ... (QX) ... (QY) ... (QZ) ... (RA) ... (RB) ... (RC) ... (RD) ... (RE) ... (RF) ... (RG) ... (RH) ... (RI) ... (RJ) ... (RK) ... (RL) ... (RM) ... (RN) ... (RO) ... (RP) ... (RQ) ... (RR) ... (RS) ... (RT) ... (RU) ... (RV) ... (RW) ... (RX) ... (RY) ... (RZ) ... (SA) ... (SB) ... (SC) ... (SD) ... (SE) ... (SF) ... (SG) ... (SH) ... (SI) ... (SJ) ... (SK) ... (SL) ... (SM) ... (SN) ... (SO) ... (SP) ... (SQ) ... (SR) ... (SS) ... (ST) ... (SU) ... (SV) ... (SW) ... (SX) ... (SY) ... (SZ) ... (TA) ... (TB) ... (TC) ... (TD) ... (TE) ... (TF) ... (TG) ... (TH) ... (TI) ... (TJ) ... (TK) ... (TL) ... (TM) ... (TN) ... (TO) ... (TP) ... (TQ) ... (TR) ... (TS) ... (TT) ... (TU) ... (TV) ... (TW) ... (TX) ... (TY) ... (TZ) ... (UA) ... (UB) ... (UC) ... (UD) ... (UE) ... (UF) ... (UG) ... (UH) ... (UI) ... (UJ) ... (UK) ... (UL) ... (UM) ... (UN) ... (UO) ... (UP) ... (UQ) ... (UR) ... (US) ... (UT) ... (UU) ... (UV) ... (UW) ... (UX) ... (UY) ... (UZ) ... (VA) ... (VB) ... (VC) ... (VD) ... (VE) ... (VF) ... (VG) ... (VH) ... (VI) ... (VJ) ... (VK) ... (VL) ... (VM) ... (VN) ... (VO) ... (VP) ... (VQ) ... (VR) ... (VS) ... (VT) ... (VU) ... (VV) ... (VW) ... (VX) ... (VY) ... (VZ) ... (WA) ... (WB) ... (WC) ... (WD) ... (WE) ... (WF) ... (WG) ... (WH) ... (WI) ... (WJ) ... (WK) ... (WL) ... (WM) ... (WN) ... (WO) ... (WP) ... (WQ) ... (WR) ... (WS) ... (WT) ... (WU) ... (WV) ... (WW) ... (WX) ... (WY) ... (WZ) ... (XA) ... (XB) ... (XC) ... (XD) ... (XE) ... (XF) ... (XG) ... (XH) ... (XI) ... (XJ) ... (XK) ... (XL) ... (XM) ... (XN) ... (XO) ... (XP) ... (XQ) ... (XR) ... (XS) ... (XT) ... (XU) ... (XV) ... (XW) ... (XX) ... (XY) ... (XZ) ... (YA) ... (YB) ... (YC) ... (YD) ... (YE) ... (YF) ... (YG) ... (YH) ... (YI) ... (YJ) ... (YK) ... (YL) ... (YM) ... (YN) ... (YO) ... (YP) ... (YQ) ... (YR) ... (YS) ... (YT) ... (YU) ... (YV) ... (YW) ... (YX) ... (YY) ... (YZ) ... (ZA) ... (ZB) ... (ZC) ... (ZD) ... (ZE) ... (ZF) ... (ZG) ... (ZH) ... (ZI) ... (ZJ) ... (ZK) ... (ZL) ... (ZM) ... (ZN) ... (ZO) ... (ZP) ... (ZQ) ... (ZR) ... (ZS) ... (ZT) ... (ZU) ... (ZV) ... (ZW) ... (ZX) ... (ZY) ... (ZZ)

FILE NO.	DATE PLOTTED	BY

DATE	DESIGN	DATE	PROJECT	SHEET TOTAL
				3
				5



REGISTERED ENGINEER - CIVIL
 ALL DIMENSIONS ARE IN INCHES UNLESS INDICATED OTHERWISE
 THIS DRAWING IS THE PROPERTY OF THE ENGINEER AND IS NOT TO BE REPRODUCED OR COPIED IN ANY MANNER WITHOUT HIS WRITTEN CONSENT

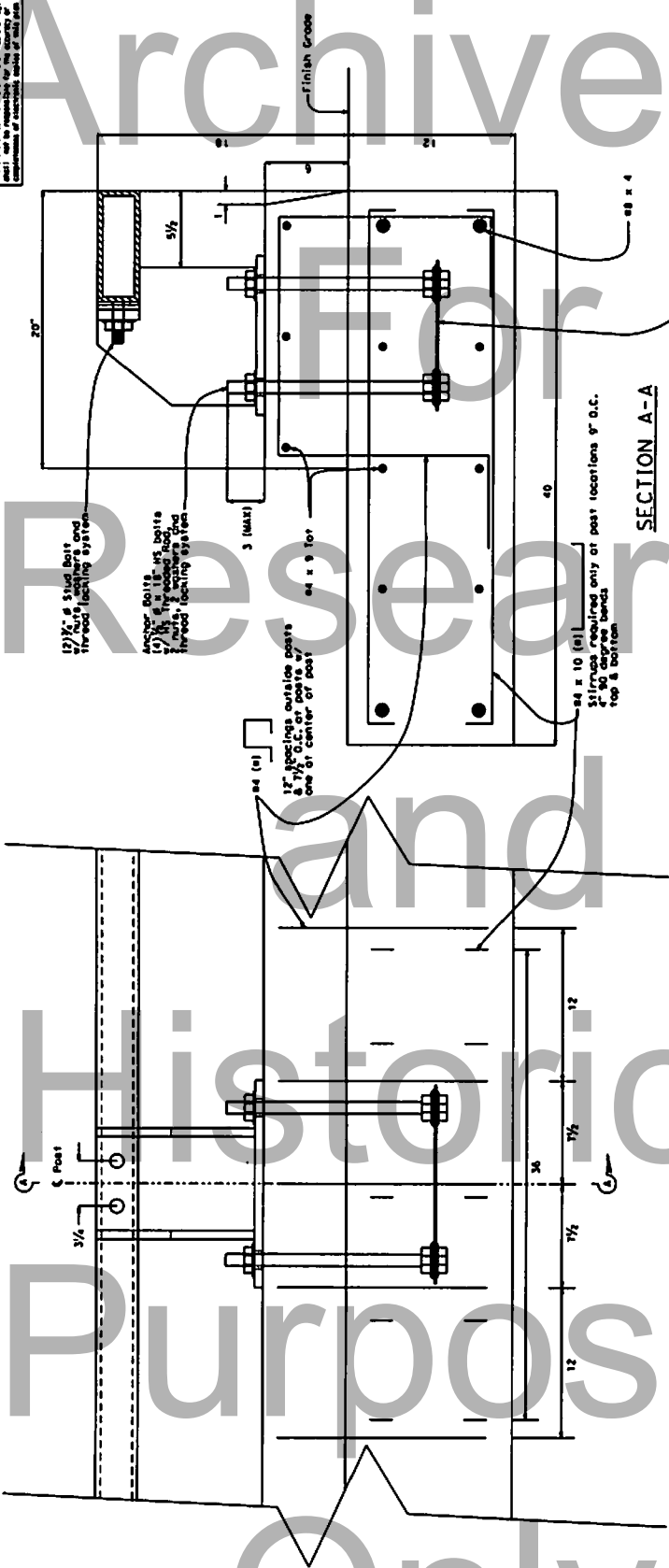

- MATERIAL:**
- A. All structural steel shall be A36, structural tubing shall be 4500 Grade B except as noted.
 - B. All bolts shall be high strength conforming to ASTM A325.
 - C. Stud bolts shall be ASTM A108 and torque to 100 ft.-lbs.
 - D. Minor Concrete
- (#1) Surface cover 2"

NO SCALE
 ALL DIMENSIONS ARE IN INCHES UNLESS INDICATED OTHERWISE

STATE OF CALIFORNIA DEPARTMENT OF TRANSPORTATION		DIVISION OF RESEARCH AND INNOVATION ROADSIDE SAFETY RESEARCH GROUP		LOW-PROFILE BARRIER LOCATION MAP AND GENERAL PLAN	
BY	DATE	BY	DATE	BY	DATE
DESIGNED BY	1/15/88	CHECKED BY		APPROVED BY	
DRAWN BY		IN CHARGE		DATE	
RELATIVE CROSS SCALE 1" = 10' HORIZ			RELATIVE PLAN SCALE 1" = 100' HORIZ		

DATE PLOTTED = 04/12/88
 TIME PLOTTED = 09:12

DESIGN COUNTY	ROUTE	POST MILE TOTAL PROJECT	SHEET TOTAL SHEETS
		3	3



REGISTERED ENGINEER - CIVIL
 STATE OF CALIFORNIA
 CIVIL ENGINEER
 No. 12345

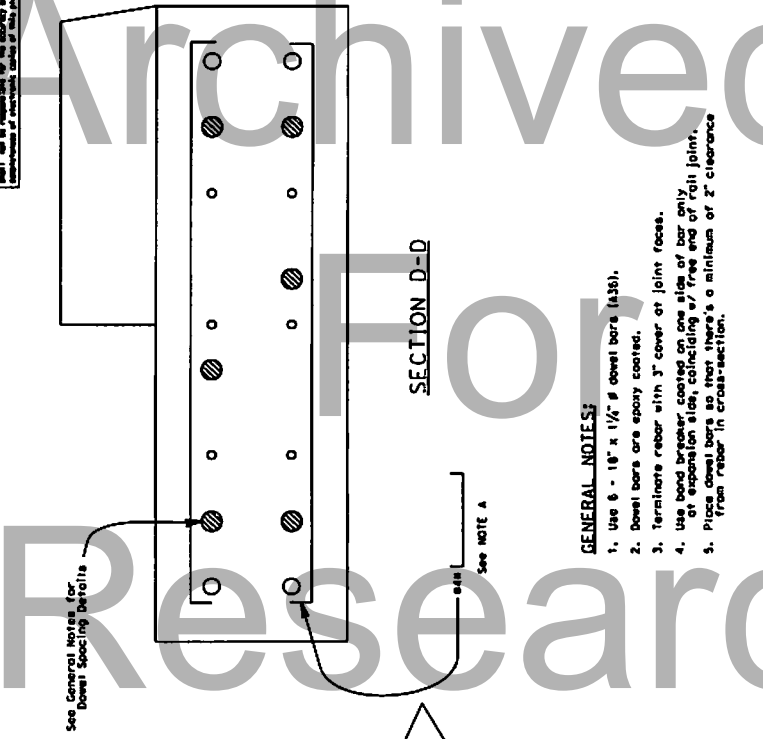

- GENERAL NOTES:**
1. Use 6 - 18" x 1/4" # 4 dowel bars (ASB).
 2. Dowel bars are epoxy coated.
 3. Terminate rebar with 3" cover at joint faces.
 4. Use lead bristles coated on one side of bar only at expansion joint location for casting and joint joint.
 5. Place dowel bars in steel shapers a minimum of 2" clearance from rebar in cross-section.

NOTE A
 1. No dowel bars below expansion joint
 2. No dowel bars above expansion joint
 3. No dowel bars at top and bottom

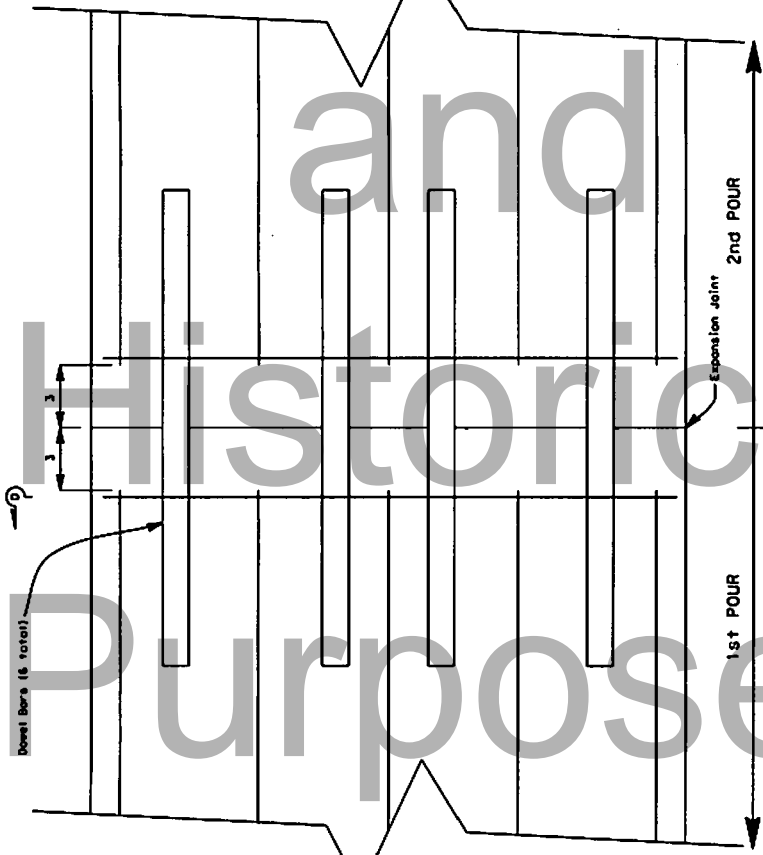

EXPANSION JOINT (TOP VIEW)

NO SCALES
 ALL DIMENSIONS ARE IN INCHES UNLESS OTHERWISE SHOWN

DESIGN COUNTY	ROUTE	POST MILE TOTAL PROJECT	SHEET TOTAL SHEETS
		3	3

REGISTERED ENGINEER - CIVIL
 STATE OF CALIFORNIA
 CIVIL ENGINEER
 No. 12345

STATE OF CALIFORNIA
 DEPARTMENT OF TRANSPORTATION

OFFICE OF RESEARCH AND INNOVATION
ROADSIDE SAFETY RESEARCH GROUP

RELATIVE NUMBER SCALE
 0 1 2 3
 1/8" = 1'-0"

...View Details/US-10p

FILE # 12345

DATE PLOTTED = 04/15/2024