

Project to Replace Temporary Wainiha Bridges

Project Primary Purpose

The primary purpose of the project is to replace the three Wainiha temporary bridges (referred to as Wainiha Bridges 1, 2, and 3) to maintain continued access along Kuhio Highway.

Secondary Needs

Bridges 2 and 3 do not currently operate efficiently.

- Bridges 2 and 3 can pose problems if two vehicles traveling opposing directions enter the bridge at the same time.
- Visibility at Bridges 2 and 3 is less than adequate. Contributing factors include: rail height and spacing, roadway and bridge elevation, and overgrowth of vegetation.

Ongoing maintenance requirements need to be manageable.

- Timber decks and railings on original bridges needed frequent repairs or replacement due to weathering and collision damage from errant vehicles.
- Temporary ACROW bridges require maintenance in the form of corrosion protection and bolt tightening.

Future proposed improvements need to consider the context of the historic roadway in project design.

- The road is significant for its state and local significance in the areas of engineering, transportation, and social history. Proposed improvements should take into consideration the historic character of the roadway.

Vehicle Bridge Rails

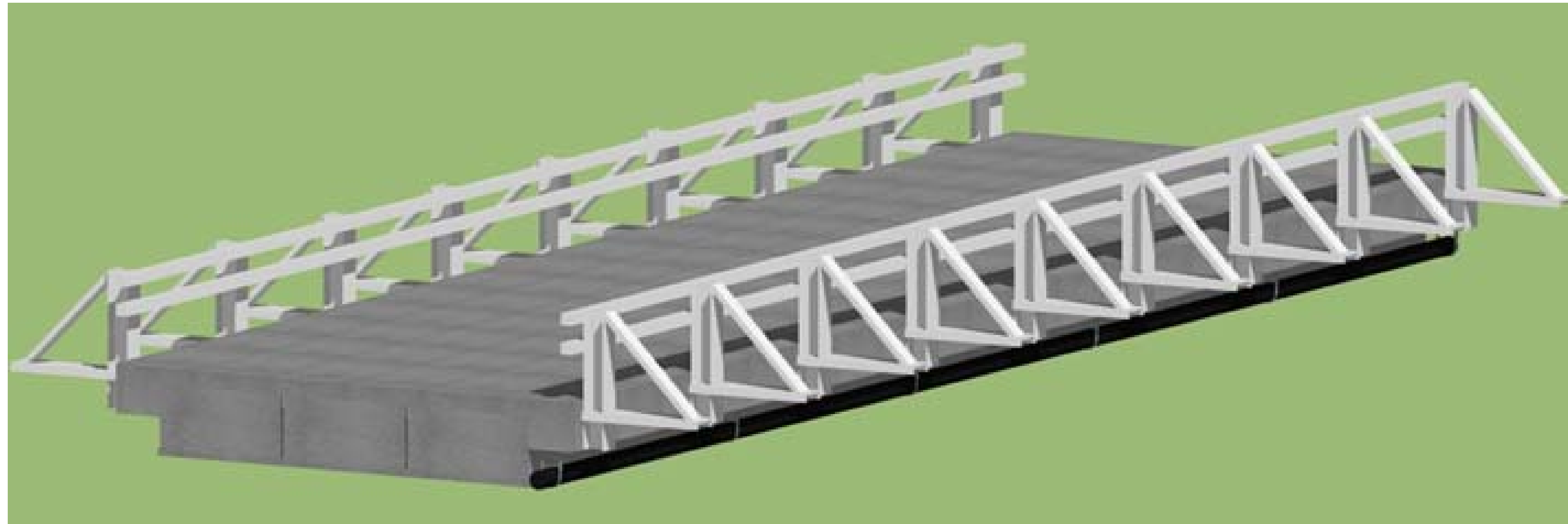

CA Type 115

- Vehicle rail = 2'-6" tall
- Side-mounted (edge of deck = 18" thick)
- Narrowest out-to-out bridge width
- Post spacing = 8' max.

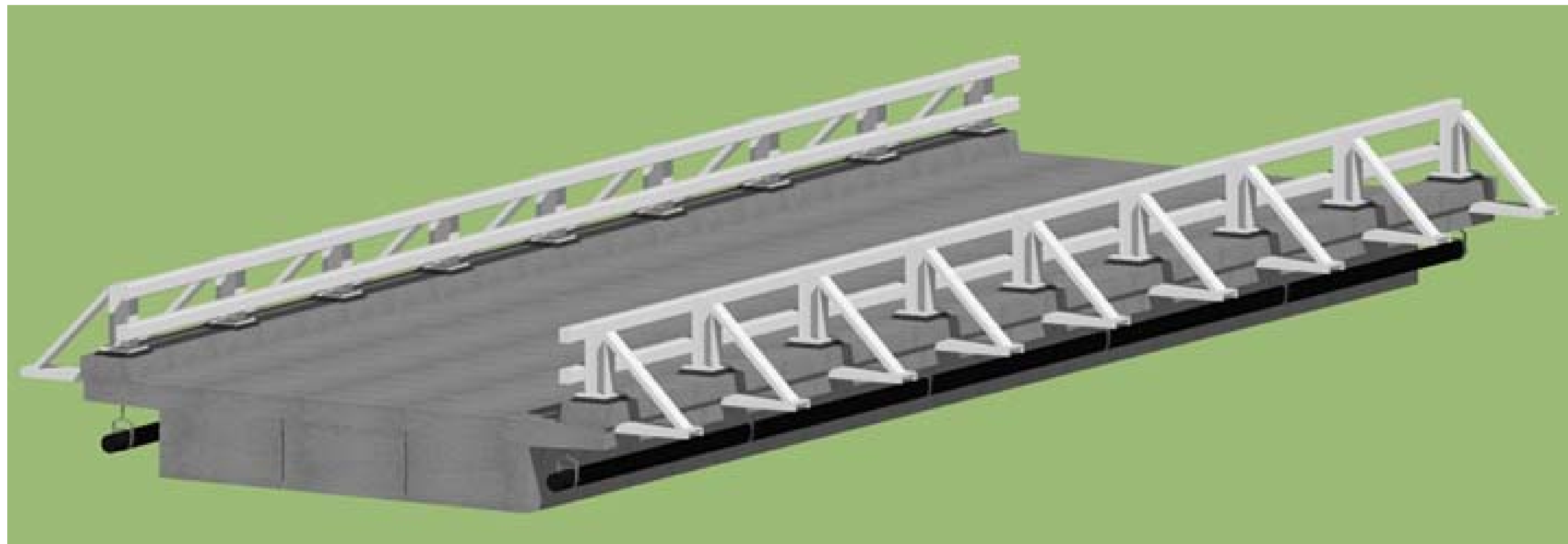

OR BR206

- Vehicle rail = 2'-8 1/2" tall
- Curb-mounted (edge of deck = 15" thick)
- Widest out-to-out bridge width
- Post spacing = 10' max.

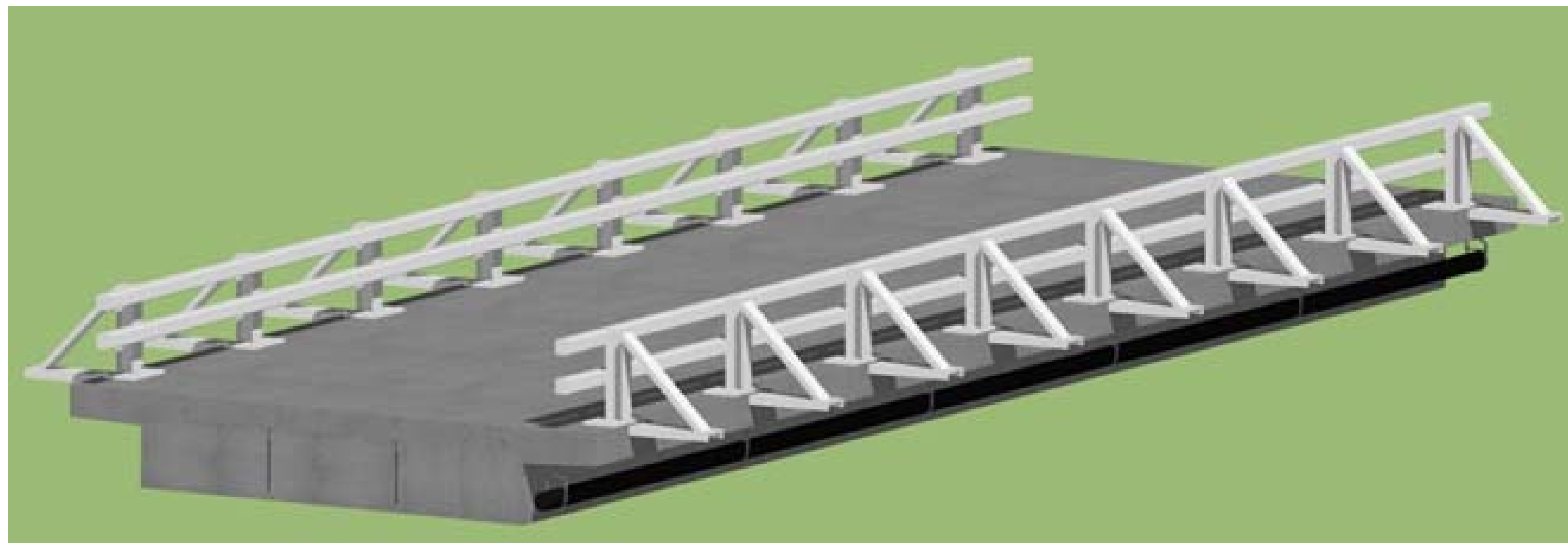

WI Type M

- Vehicle rail = 2'-6" tall
- Top-mounted (edge of deck = 10.5" thick)
- Post spacing = 6' 6" max.

Vehicle/Bicycle Bridge Rails

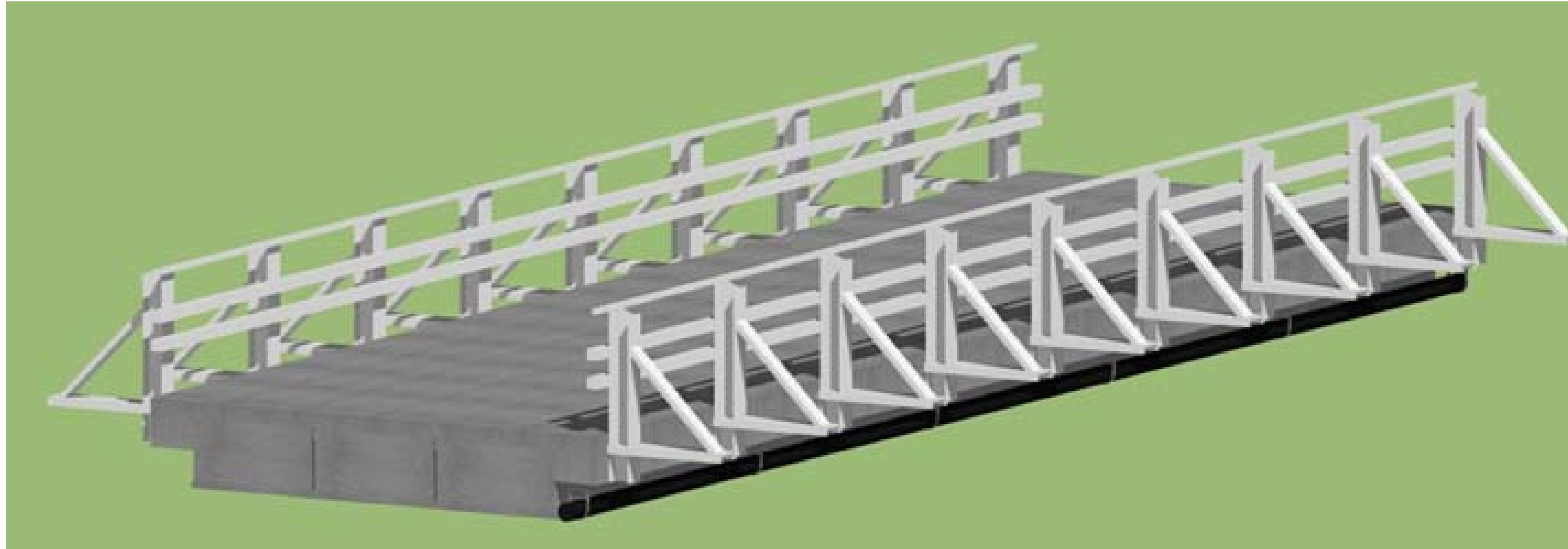

CA Type 116

- Vehicle/bicycle rail = 3'-8" tall
- Side-mounted (edge of deck = 18" thick)
- Narrowest out-to-out bridge width
- Post spacing = 8' max.

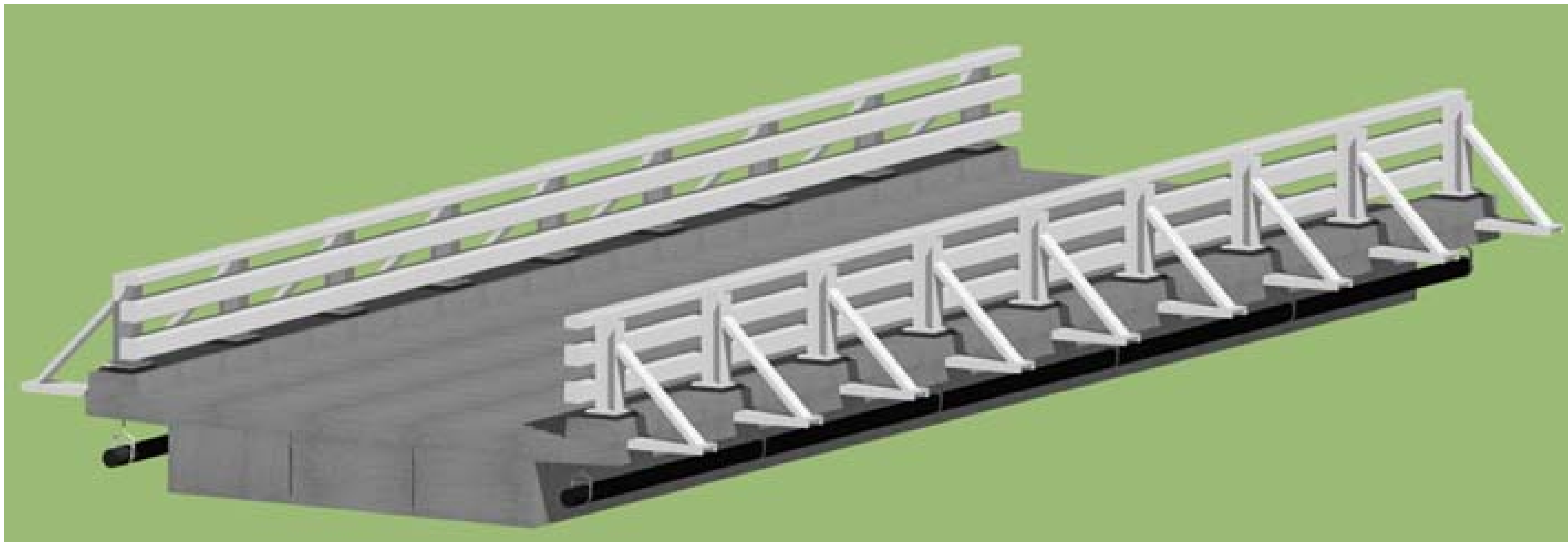

OR BR208

- Vehicle/bicycle rail = 3'-6" tall
- Curb-mounted (edge of deck = 15" thick)
- Widest out-to-out bridge width
- Post spacing = 10' max.

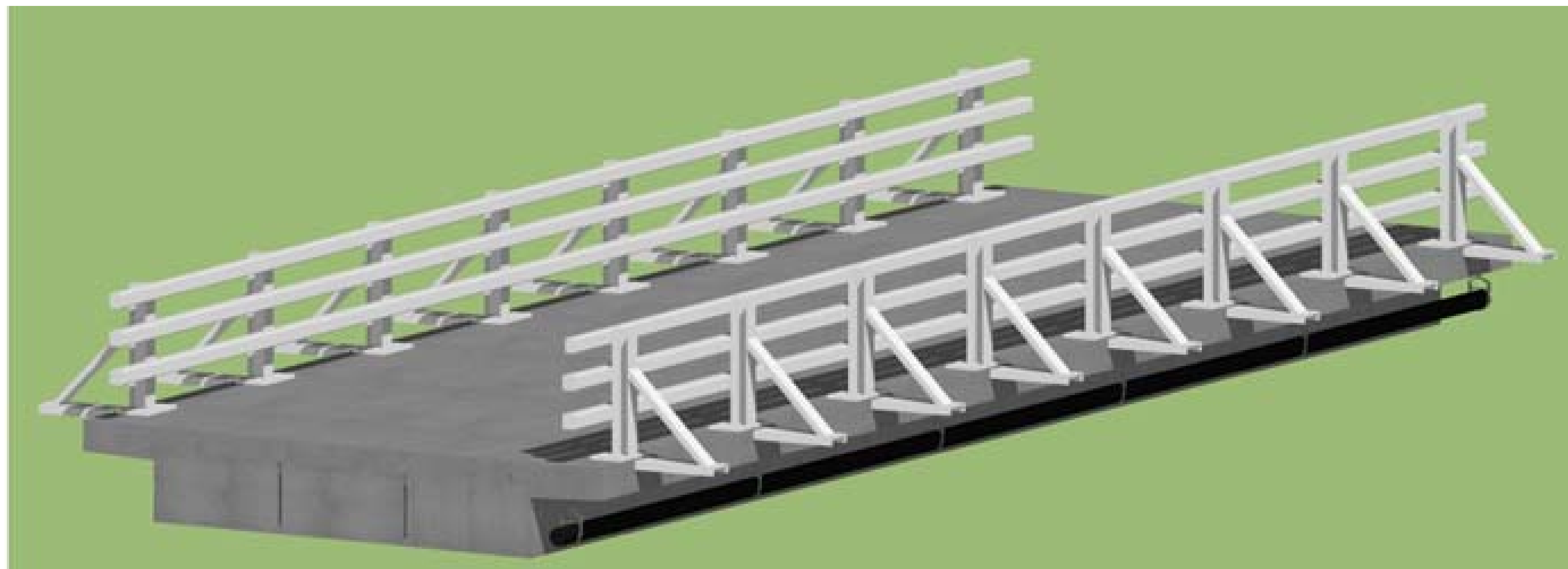

WI Type M (Comb)

- Vehicle/bicycle rail = 3'-6" tall
- Top-mounted (edge of deck = 10 .5" thick)
- Post spacing = 6' 6" max.

Bridge Deck Considerations



Bridge Width—11-foot Considerations

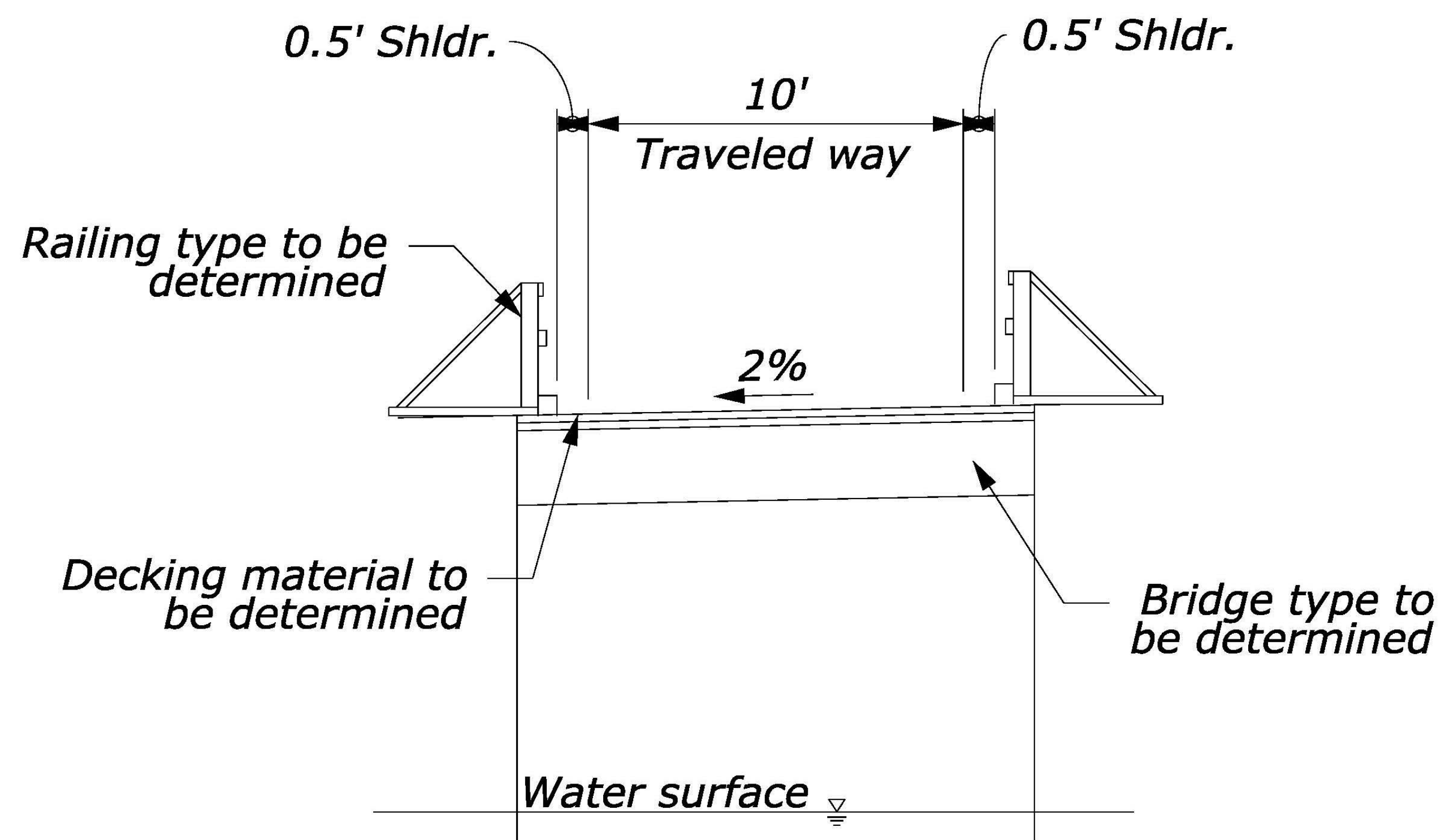

11' WIDTH

Advantages or Disadvantages

Bridge Width—16-foot Considerations

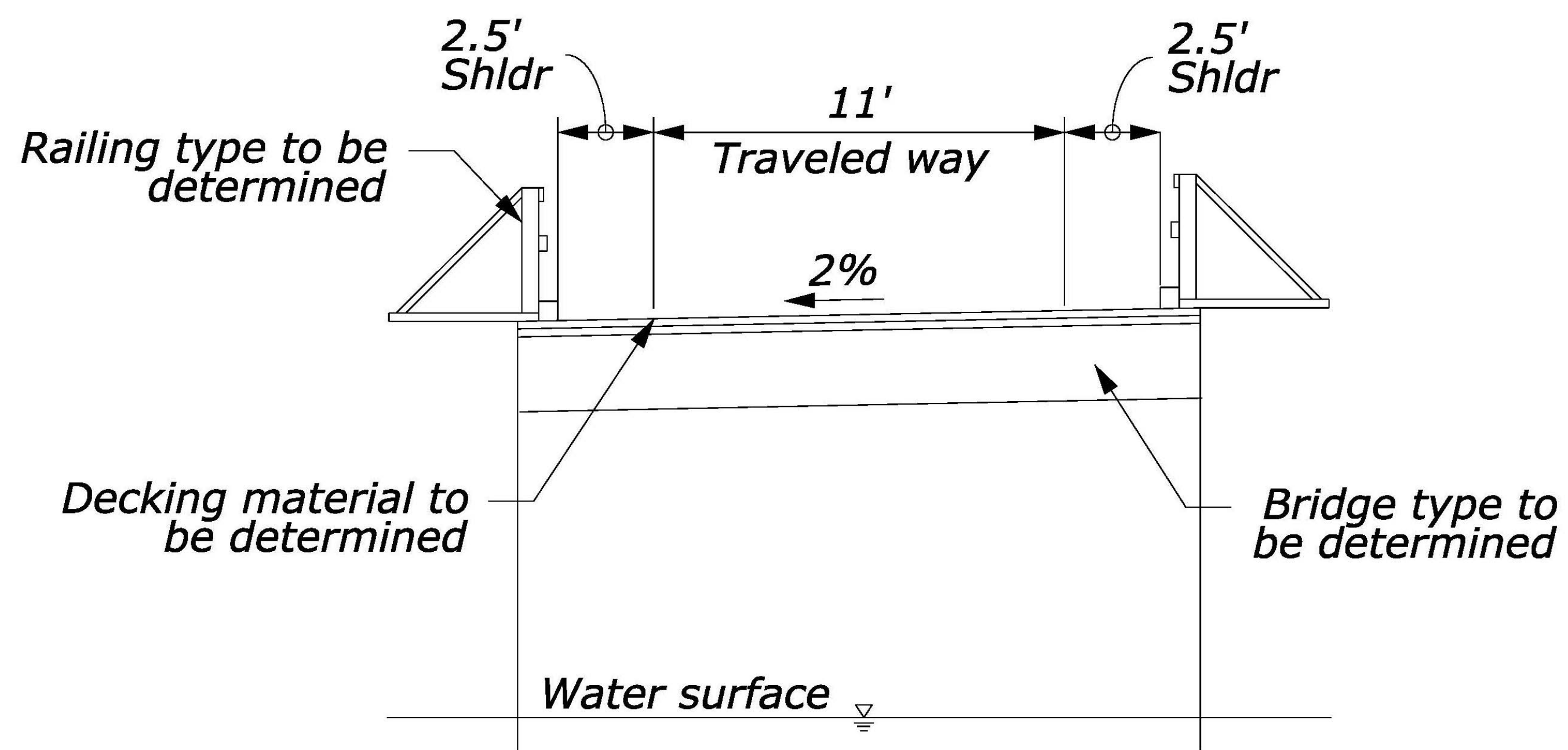

16' WIDTH

Advantages or Disadvantages

**Bridge Width—
No Action Alternative**

Advantages and Disadvantages

**Bridge Width—
Any Other Considerations?**

**Other Bridge Width Recommendations
and Potential Benefits?**

Other Alternative Considerations?

Considerations with Advancing Two-Lane Bridge

Construction Approach and Alignment Considerations

Waikoko, Waioli, Waipa Temporary Access Considerations