

Web-Based Training for FHWA Roadway Lighting Workshop

Module 3: Street and Roadway Lighting Design



FHWA Safety Program



U.S. Department of Transportation
Federal Highway Administration



<http://safety.fhwa.dot.gov>

Web-Based Training for FHWA Roadway Lighting Workshop

Participant Workbook

Module 3: Street and Roadway Lighting Design

(Other modules include:

Module 1: Roadway Lighting Design Overview

Module 2: Lighting Hardware and Light Source Considerations for Roadway Lighting

Module 4: Other Roadway Lighting Topics)

May 2018

NOTICE

This document is disseminated under the sponsorship of the U.S. Department of Transportation in the interest of information exchange. The United States Government assumes no liability for its contents or the use thereof. This Report does not constitute a standard, specification, or regulation.

The contents of this Report reflect the views of the contractor, who is responsible for the accuracy of the data presented herein. The contents do not necessarily reflect the official policy of the U.S. Department of Transportation.

The United States Government does not endorse products or manufacturers named herein. Trade or manufacturers' names appear herein solely because they are considered essential to the object of this report.

QUALITY ASSURANCE STATEMENT

The Federal Highway Administration (FHWA) provides high-quality information to serve Government, industry, and the public in a manner that promotes public understanding. Standards and policies are used to ensure and maximize the quality, objectivity, utility, and integrity of its information. FHWA periodically reviews quality issues and adjusts its programs and processes to ensure continuous quality improvement.

TECHNICAL REPORT DOCUMENTATION PAGE

1. Report No. FHWA-SA-18-035		2. Government Accession No.		3. Recipient's Catalog No.	
4. Title and Subtitle Web-Based Training for FHWA Roadway Lighting Workshop Module 3: Street and Roadway Lighting Design			5. Report Date May 2018		
			6. Performing Organization Code		
7. Author(s) Daniel C. Frering, John D. Bullough, Kevin Chiang, Leverson Boodlal			8. Performing Organization Report No.		
9. Performing Organization Name and Address KLS Engineering, LLC (Prime), 45155 Research PI, Suite 200, Ashburn, VA 20147			10. Work Unit No. (TRAIS)		
			11. Contract or Grant No. DTFH6116D00017, TOPR No. 16-16		
12. Sponsoring Agency Name and Address Federal Highway Administration Office of Safety 1200 New Jersey Ave. SE Washington, DC 20590			13. Type of Report and Period Covered Report (2016-2018)		
			14. Sponsoring Agency Code FHWA		
15. Supplementary Notes Joseph Cheung from FHWA served as the Project Manager. Cathy Satterfield, George Merritt, Michelle Arnold and Wilmari Valentin Medina from FHWA provided helpful technical comments.					
16. Abstract This document serves as a participant workbook for Web-Based Training for FHWA Roadway Lighting Workshop, Module 3: Street and Roadway Lighting Design. Module 3 covers lighting design criteria, calculations, field measurements, and light pollution. Other modules include Module 1: Roadway Lighting Design Overview, Module 2: Lighting Hardware and Light Source Considerations for Roadway Lighting, and Module 4: Other Roadway Lighting Topics.					
17. Key Words Roadway lighting, safety, visibility, crash avoidance			18. Distribution Statement No restrictions		
19. Security Classif. (of this report) Unclassified		20. Security Classif. (of this page) Unclassified		21. No. of Pages 67	22. Price
Form DOT F 1700.7 (8-72)			Reproduction of completed page authorized		

List of Acronyms and Abbreviations

AASHTO	American Association of State Highway and Transportation Officials
BUG	Backlight-uplight-glare
CCT	Correlated color temperature
cd	Candela
cd/m ²	Candela per square meter
CU	Coefficient of utilization
fc	Footcandle
HPS	High pressure sodium
HS	House side
IES	Illuminating Engineering Society
LED	Light emitting diode
LDD	Luminaire dirt depreciation
LLD	Lamp lumen depreciation
LLF	Light loss factor
LM	Lighting measurement guide
LZ	Lighting zone (environmental)
MH	Mounting height
OSP	Outdoor site-lighting performance
Qo	Pavement brightness factor
RP	Recommended practice
SS	Street side
TM	Technical memorandum

Module 3: Street and Roadway Lighting Design

Street and Roadway Lighting Design Overview ***Module 3, Slide 1***

This section of the Participant Workbook will help you review the content for Module 3, titled *Street and Roadway Lighting Design*. The module slide title and slide number at the top of each workbook page will help you locate content within the workbook that matches content in the online modules.

Navigating This Course
Module 3, Slide 2

This slide in the online module describes how to navigate the course module. It is similar to the instructions in this workbook. This section of the workbook also contains an extended example problem where you can apply the knowledge gained from this module.

Course Objectives
Module 3, Slide 3

Following completion of this module, the user will be able to accomplish the following objectives:

- Select design criteria for roadway lighting types.
- Estimate luminaire spacing for different road types.
- Calculate average illuminance and illuminance uniformity.
- Analyze lighting pollution and apply mitigation techniques.

Table of Contents
Module 3, Slide 4

Section 1: Lighting Design Criteria – illuminance, luminance, veiling luminance, pavement characteristics, uniformity.

Section 2: Calculations – light loss factors, coefficient of utilization, luminaire spacing, luminaire layouts, roadway lighting design software.

Section 3: Field Measurements – luminance, illuminance, uniformity.

Section 4: Light Pollution – environmental zones, sky glow, light trespass.

Lighting Design Criteria
Module 3, Slide 5

This module section discusses lighting design criteria.

Road Surface Illuminance Module 3, Slide 6

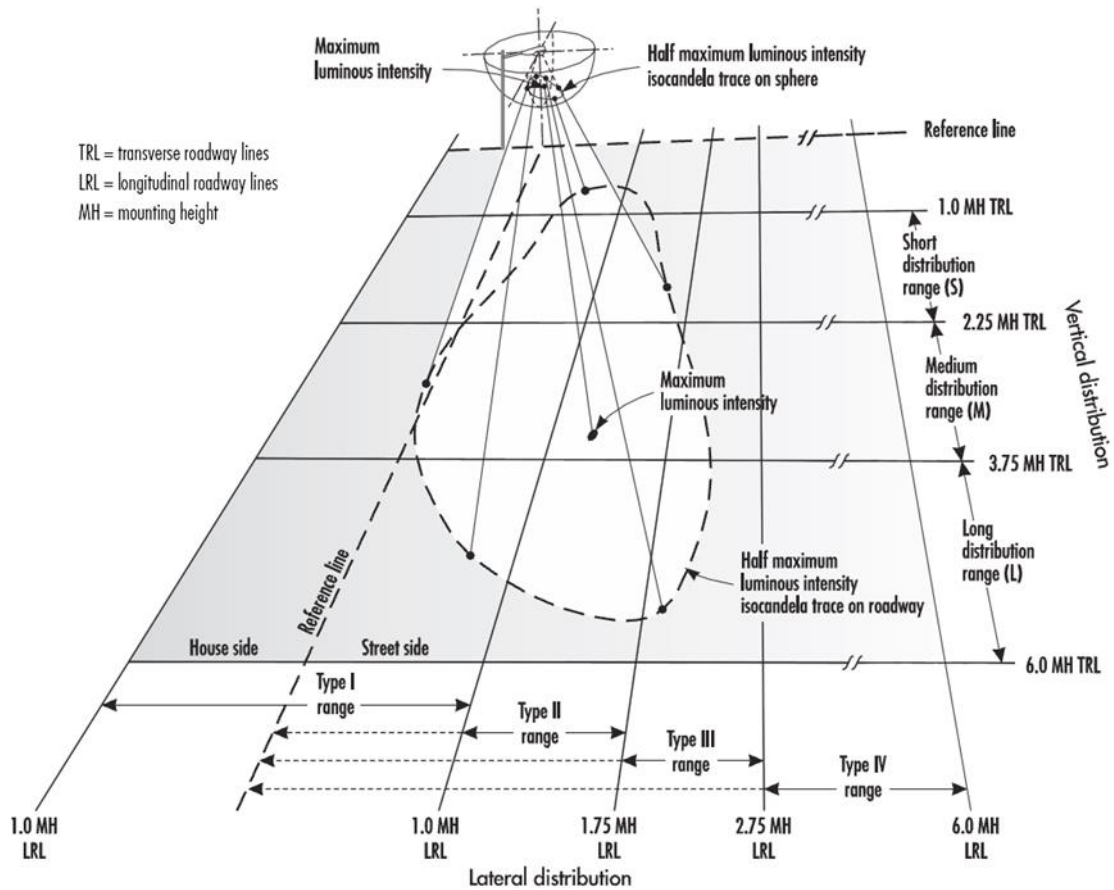

Illustration of a typical roadway luminaire distribution.

Illuminance was discussed in module 1 of this course. It is the amount of light (lumens) incident on a surface, for example a roadway, per unit area, such as square foot (footcandle) or square meter (lux). Illuminance is used as a design criterion for intersections and for curved roadways. It is also used in the field to evaluate whether a particular roadway meets recommended lighting conditions (illuminance or luminance).

The illuminance on a road surface is based on two main factors:

- The light intensity of a luminaire.
- The luminaire mounting height and geometry.

The farther the luminaire is from the surface it is illuminating, the lower the illuminance will be. Illuminance is inversely proportional to the square of the distance between the luminaire and the surface being illuminated. Thus, in a roadway application, as luminaire mounting height increases, illuminance on the roadway decreases exponentially.

Road Surface Illuminance (cont'd.)
Module 3, Slide 7

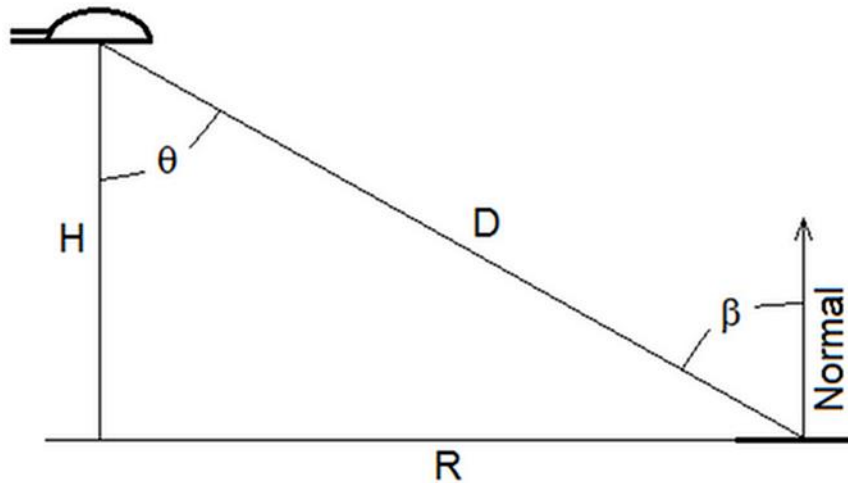

$$\text{Illuminance on the Horizontal Plane} = \text{Intensity} \times \cos \theta / D^2$$

Road surface illuminance.

The calculation for illuminance is relatively simple.

$$\text{Illuminance (E)} = \frac{\text{Intensity (I)} \times \text{cosine of angle from the luminaire } (\theta)}{\text{Distance squared } (D^2)}$$

If we wanted to calculate the illuminance at a point directly under a luminaire, we simply need to know the intensity of the luminaire at its center beam [e.g., 1000 candelas (cd)], the cosine of the angle from the luminaire (the angle directly under the luminaire is zero and so has a cosine of one) and the distance between the luminaire and the roadway surface (e.g., 5 meters), as shown in the equation below:

$$\frac{1000 \text{ cd} \times 1}{25} = 40 \text{ lux}$$

As shown in the illustration above, to calculate the illuminance at a point 10 meters away from this same luminaire, we would need to use the cosine of the angle between where the luminaire is mounted and the point we wish to calculate (a 63° angle, θ, has a cosine of 0.45), the total intensity of the luminaire at that angle (800 cd), and the distance between that point and the luminaire (the distance D is 11 meters). The calculation is:

$$\frac{800 \text{ cd} \times 0.45}{121} = 3 \text{ lux}$$

Road Surface Illuminance (cont'd.)
Module 3, Slide 8

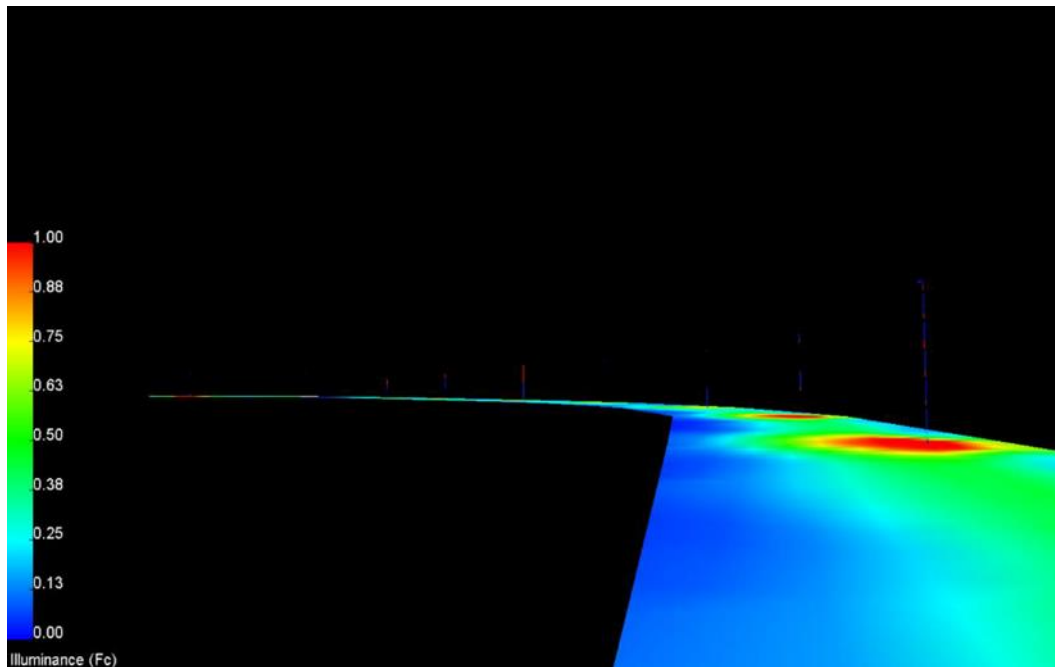

A typical illuminance map produced by a computer software program. The colors on the road indicate different illuminance levels (in this case, in footcandles) on the roadway surface.

Before the era of computers, engineers used the point method to calculate illuminance, as described on the previous slide, at enough points along a roadway to provide a good idea of what the overall light levels were throughout an entire roadway lighting installation. However, this is rarely done today.

Today these types of illuminance calculations are done using computer software. This course module will discuss some of these software types in later slides.

Road Surface Luminance
Module 3, Slide 9

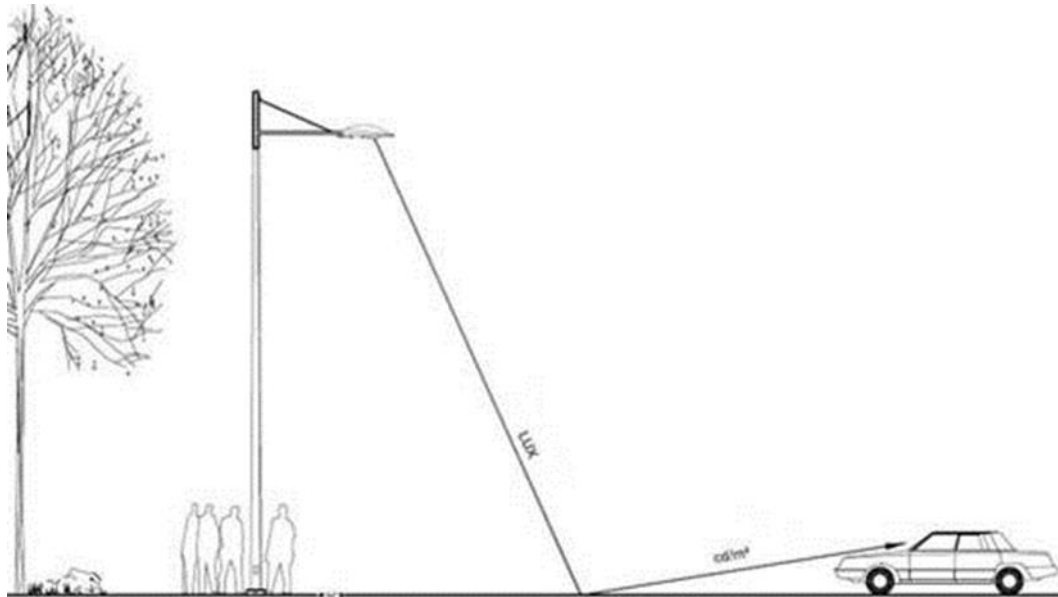

Illustration of roadway luminance measurements. The observation angle from the point on the road to the observer is 1 degree. The observer distance from the point on the road where luminance is being measured or calculated is 83.07 meters. The observer height from the road surface is 1.45 meters.

The next design criterion used for roadways is luminance. This is used for relatively straight sections of roadways and streets. The definition of luminance was discussed in Module 1 of this course. Unlike illuminance, which is light on a surface, luminance is what we actually see.

The luminance of a road surface is based on:

- The illuminance on the road surface.
- The geometry of the installation.
- The reflection characteristics of the pavement.
- The location of the observer.

The observer location used in the luminance calculation is assumed to be 83.07 meters from the calculation point, at an eye height of 1.45 meters. This results in an observation angle of 1 degree. This observer location is used for all calculation points. All pavement reflection characteristics are also measured at the 1 degree observation angle.

Pavement Surface Characteristics
Module 3, Slide 10

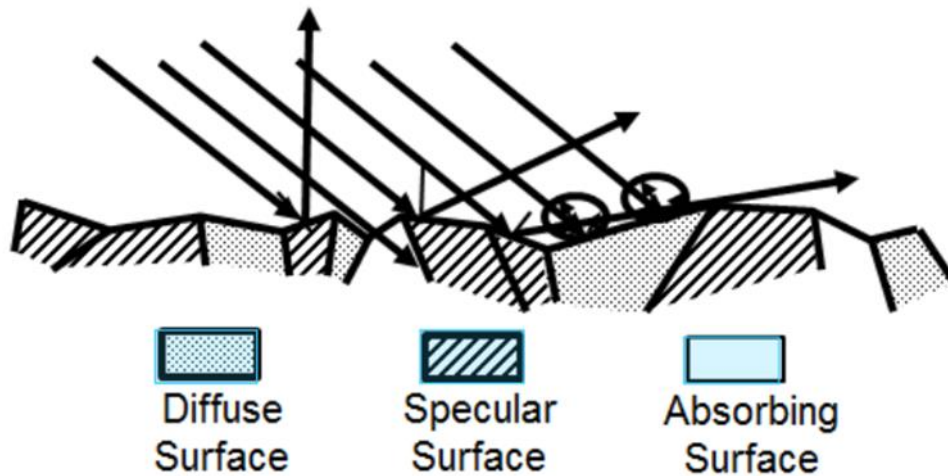

Roadway surface types. **Diffuse surface** reflection occurs when a rough surface causes reflected rays of light to travel in different directions. **Specular surface** reflection occurs when a smooth surface causes reflected rays to travel in the same direction. An **absorbing surface** prevents reflection or diffusion of light striking on the surface.

The type of pavement used for roadways will affect the luminance and the calculation of the visibility of small targets or objects on the roadway. Roadway surfaces are classified based on their reflection characteristics.

Pavement is a mixture of aggregate stone and a binder material, usually concrete or asphalt. Studies show that reflection depends on the texture, type, and structure of the materials used. Reflection from pavement is a combination of diffuse and specular reflection.

Pavement Surface Classification
Module 3, Slide 11

Class	Q _o	Description	Mode of Reflectance
R1	0.10	Portland cement concrete road surface. Asphalt road surface with a minimum of 12 percent of the aggregates composed of artificial brightener (e.g., Synopal) aggregates (e.g., labradorite, quartzite).	Mostly Diffuse
R2	0.07	Asphalt road surface with an aggregate composed of a minimum 60 percent gravel (size greater than 1 cm (0.4 in.)). Asphalt road surface with 10 to 15 percent artificial brightener in aggregate mix. (Not normally used in North America).	Mixed (diffuse and specular)
R3	0.07	Asphalt road surface (regular and carpet seal) with dark aggregates (e.g., trap rock, blast furnace slag); rough texture after some months of use (typical highways).	Slightly Specular
R4	0.08	Asphalt road surface with very smooth texture.	Mostly Specular

Reflection properties have been measured for hundreds of different road surfaces since the 1960s. All of these measurements have been under a 1 degree observation angle for roadway lighting. The results were generalized into four road classes based on reflection criteria, shown on the chart above. In the chart, Q_o represents the general brightness of the surface.

***Veiling Luminance
Module 3, Slide 12***



A glaring luminaire along a roadway at night. Lighting engineers use the veiling luminance metric to limit potential glare from roadway luminaires.

Another factor to consider in roadway lighting design is veiling luminance. Lighting engineers use veiling luminance as a way to limit glare from roadway luminaires. Veiling luminance is the effect produced by bright sources or objects in the visual field that causes decreased visibility and visual performance.

Veiling luminance compares the luminance of the luminaires on the roadway to the luminance of the area surrounding them. This results in a ratio between the two luminances, the veiling luminance produced by the luminaire to the average luminance of the roadway area.

Roadway lighting guidelines, such as the Illuminating Engineering Society's (IES's) recommended practice for roadway lighting (RP-8) set limits on this ratio for various types of roadways as a means of limiting potential glare for drivers.

Veiling Luminance (cont'd.)
Module 3, Slide 13

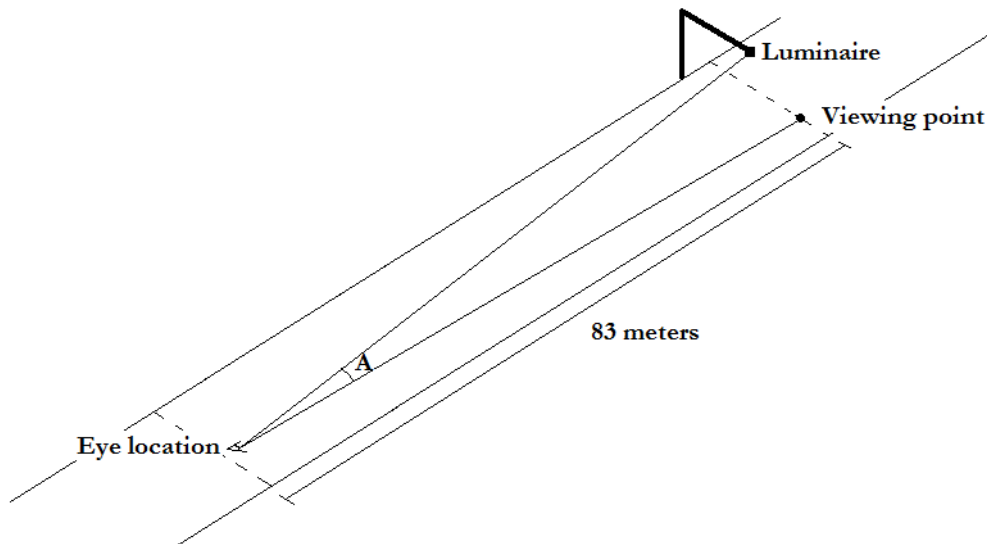

An illustration of the method used to calculate veiling luminance.

Engineers calculate veiling luminance for a driver looking at a point on the road located 83 meters ahead. It is determined by the vertical illuminance (E, in lux) from the luminaire falling on the driver's eye location, and the angle (A, in degrees) between the luminaire and the driver's line of sight. It is expressed in terms of a luminance value (L, in candelas per square meter) that is added to the luminances of an object and its background according to the formula:

$$L = 10E / A^2$$

Lighting Uniformity
Module 3, Slide 14



An expressway with relatively uniform lighting.

The last design criterion we will discuss is lighting uniformity. Uniformity recommendations apply to both illuminance and luminance, depending on which measure you are using. As the name suggests, uniformity is a measure of how evenly light is distributed along a portion of roadway. Greater uniformity improves both visibility and visual comfort for drivers.

In RP-8, the IES publishes recommended uniformity metrics for various types of roadways to help ensure that the lighting is evenly distributed. These metrics apply to both luminance and illuminance calculations. Like veiling luminance, these uniformity metrics are in the form of a ratio. The ratio is between the highest level on the roadway (max), luminance or illuminance, and the lowest (min), luminance or illuminance. For example, if the recommended uniformity ratio for a straight roadway were 6, then the maximum luminance could not exceed 6 times the minimum luminance anywhere on the section of roadway for which lighting is being designed.

Recommended Lighting Design Criteria for Roadways
Module 3, Slide 15

ROAD CLASSIFICATION	AVG. LUMINANCE L_{avg} (cd/m ²)	MAX. UNIFORMITY RATIO L_{max}/L_{min}	MAX. VEILING LUMINANCE RATIO LV_{max}/L_{avg}
FREEWAY CLASS A	0.6	6.0	0.3
FREEWAY CLASS B	0.4	6.0	0.3
EXPRESSWAY	1.0	5.0	0.3

The chart above is adapted from IES RP-8 and shows the recommended design criteria (average luminance L_{avg} , maximum uniformity ratio L_{max}/L_{min} , maximum veiling luminance ratio LV_{max}/L_{avg}) for some types of roadways in North America. Engineers and others who design lighting installations for roadways follow these guidelines to help ensure that the lighting provides the characteristics necessary to promote good visibility and visual comfort for drivers. Lighting software programs used to assist with roadway lighting design provide the information necessary to ensure compliance with the recommendations shown in this chart.

Knowledge Check
Module 3, Slide 16

True or False:

Veiling luminance is a metric used to prevent glare from roadway lighting.

- A) True
- B) False

Knowledge Check Answer
Module 3, Slide 17



Potentially glaring luminaires along a highway at night.

The correct answer is A) True.

Veiling luminance is the effect produced by bright sources or objects in the visual field that decreases visibility and visual performance. The veiling luminance metric is designed to prevent disability glare for drivers and improve visibility and visual comfort. (See Module 3, Slide 12)

Calculations for Luminaire Spacing and Layout
Module 3, Slide 18

The next section of this module will discuss calculations for the spacing and layout of luminaires for roadway lighting.

Maintained Light Levels
Module 3, Slide 19



A lamp being changed in a roadway luminaire. Light loss factors take into account frequency of lamp changes and luminaire cleanings.

All calculations for roadway lighting should result in maintained light levels, whether luminance or illuminance. Roadway lighting design uses the maintained illuminance/luminance method, which aims to provide not less than the required light levels at the worst point in the maintenance cycle of luminaire cleaning and lamp, light emitting diode (LED) module, or luminaire replacement.

To properly calculate maintained light levels we use a series of light loss factors (LLF). These factors take into account such things as dirt accumulation on luminaire surfaces, lumen depreciation from the lamp or LED, and maintenance procedures such as how often crews clean luminaires and change lamps.

Light Loss Factors (LLF)
Module 3, Slide 20



A very dirty post-top street luminaire. It's easy to see how the dirt will decrease the light output, compared to a clean luminaire.

LLFs are applied to lighting design to compensate for light depreciation over time. The two main factors to consider are:

Lamp Lumen Depreciation (LLD) – LLD is a multiplier that a lighting engineer uses in calculations to relate the initial rated output of a light source to its anticipated minimum output based on a particular relamping schedule.

Luminaire Dirt Depreciation (LDD) – LDD is a multiplier used in lighting calculations to reduce the initial light level provided by clean luminaires to the light level they will provide because of dirt collection on the luminaires at the time when it is anticipated that the luminaires will be cleaned.

Lamp Lumen Depreciation (LLD)
Module 3, Slide 21

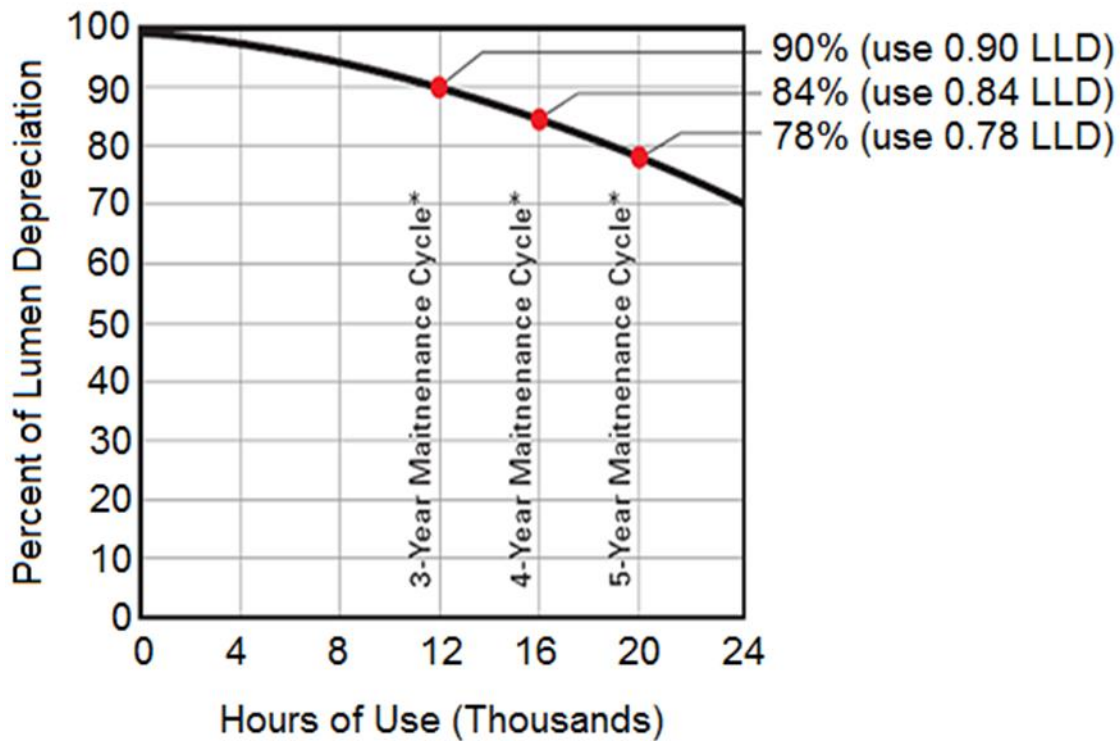

*4000 hours of use is approximately one year.

A LLD chart for a high pressure sodium (HPS) lamp.

To determine the LLD for a particular roadway lighting installation, you must first determine how often you expect to change the lamp or light source, for example, every five years. Once you have determined that, you estimate a number of hours that the lamp will operate over the time period, for example, 11 hours per night (on average) for 1,825 nights. This equals approximately 20,000 hours.

You then use the information provided by the light source manufacturers to determine the percentage of initial light output that will remain at the time when the lamp is expected to be changed. This is often provided in a graph similar to the one shown above.

Luminaire Dirt Depreciation (LDD)
Module 3, Slide 22

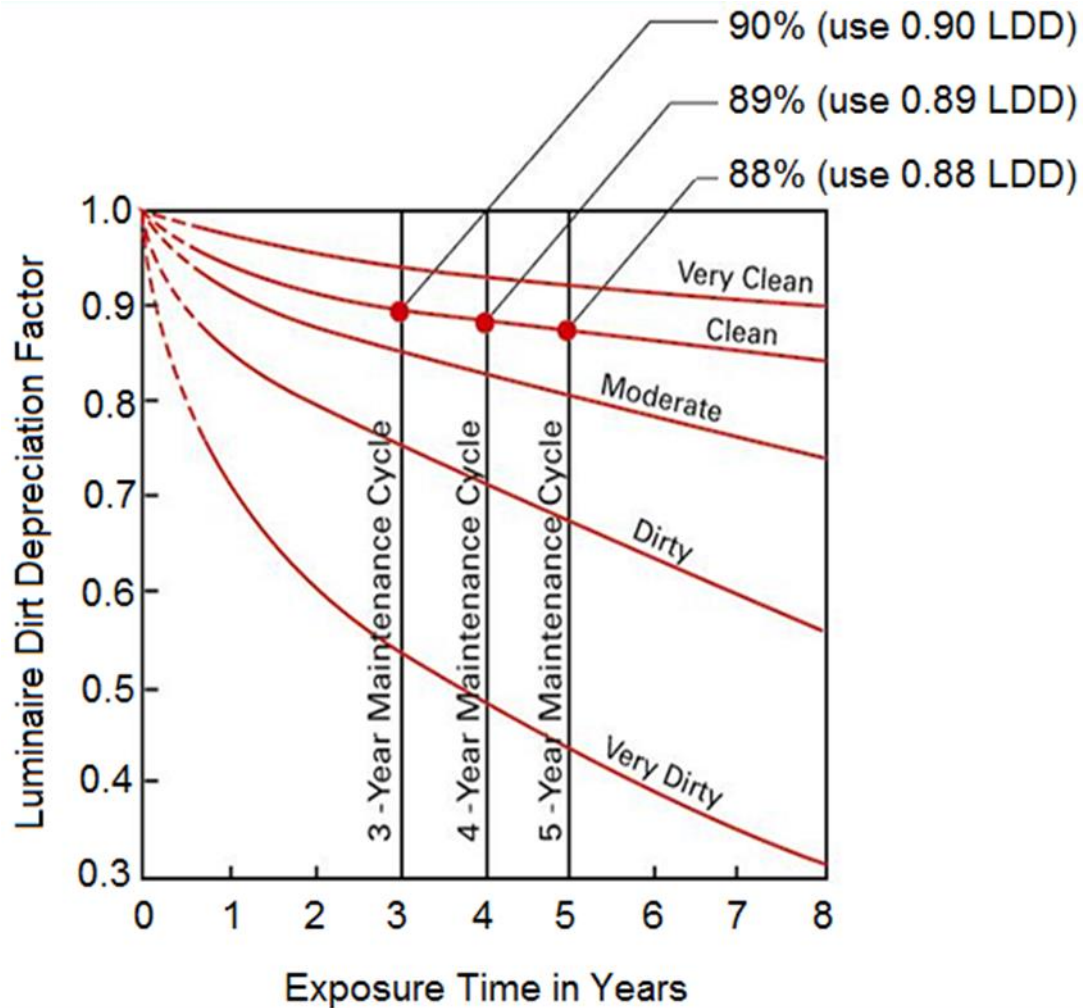

To determine the LDD factor to apply in your calculations, you first determine how frequently the luminaires will be cleaned, for example, every five years. Cleaning is typically done at the same time as relamping.

Once the maintenance scheduled is determined, you then need to decide on the type of environment in which the luminaire is or will be installed from very clean, to very dirty.

You then use a graph like the one above provided by the luminaire manufacturer to determine the LDD to use in your calculations.

Light Loss Factor Calculation
Module 3, Slide 23

Below are three sample calculations for total light loss factor using the graphs provided on the previous slides. Each calculation is for a different maintenance period. As would be expected, the longer the maintenance period, the higher the light loss factor.

Note that if maintenance of a roadway lighting installation is done by spot relamping (relamping of luminaires only when a lamp is reported to be burned out) you should use a five-year maintenance schedule.

Three-Year – Maintenance Cycle LLF Calculation:

$$0.81 \text{ (LLF)} = 0.9 \text{ (LLD)} \times 0.9 \text{ (LDD)}$$

Four-Year – Maintenance Cycle LLF Calculation:

$$0.75 \text{ (LLF)} = 0.84 \text{ (LLD)} \times 0.89 \text{ (LDD)}$$

Five-Year – Maintenance Cycle Calculation, or Maintenance by Spot Relamping LLF Calculation:

$$0.69 \text{ (LLF)} = 0.78 \text{ (LLD)} \times 0.88 \text{ (LDD)}$$

***Light Loss Factor for LEDs
Module 3, Slide 24***



An LED roadway luminaire.

Unlike all other light sources, the life of LEDs is not based on light source failure, but rather on lumen depreciation. The life of an LED is an estimate based on when the LEDs within a luminaire are expected to lose 30 percent of their light output. Therefore the LLF calculation for an LED luminaire is usually done using this LLD number (0.7) and the expected cleaning schedule for the luminaires (usually every 5 to 10 years).

So, a LLF calculation for an LED luminaire typically looks like this:

$$0.63 \text{ (LLF)} = 0.70 \text{ (LLD)} \times 0.9 \text{ (LDD)}$$

This is a conservative estimate based on the belief that LED luminaires will likely be left in place as long as they are providing light. Using an LLF of 0.63 for LED luminaires will help to ensure that the light levels calculated will still be available at the end of an LED luminaire's life. However, this will also result in a lighting installation that is significantly over-lighted when it is first installed. Some LED products can compensate for this by allowing the user to dim the lighting when first installed and then to slowly raise the power provided to the LEDs as their lumen output depreciates.

Coefficient of Utilization
Module 3, Slide 25

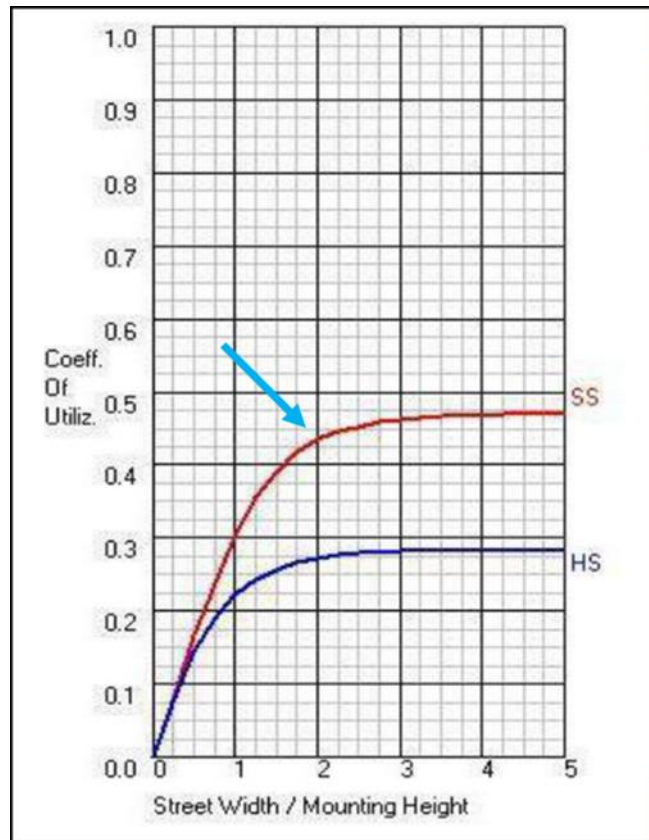

In this chart, about 43 percent (CU=0.43) of the luminaire's lumens would fall on the street, if the street were two mounting heights wide.

Before beginning a discussion of luminaire spacing, we need to understand the coefficient of utilization of a roadway luminaire.

The coefficient of utilization (CU) is a value between zero and one that indicates the proportion of lumens emitted by a roadway luminaire that will fall on the roadway. The CU value is used in preliminary estimates of the roadway illuminance produced by a lighting system. The width of the roadway is given in terms of multiples of the luminaire's mounting height.

The chart above shows one CU curve labeled SS (street side), where the horizontal axis represents the width of the roadway, in multiples of the luminaire's mounting height. The values along the vertical axis indicate the proportion of the luminaire's lumens that will fall on the roadway surface.

The other CU curve, labeled HS (house side), can be used to calculate the proportion of lumens from a luminaire that would fall outside the street area, behind the luminaire (and toward any houses located on the same side of the street as the luminaire).

Luminaire Pole Spacing
Module 3, Slide 26

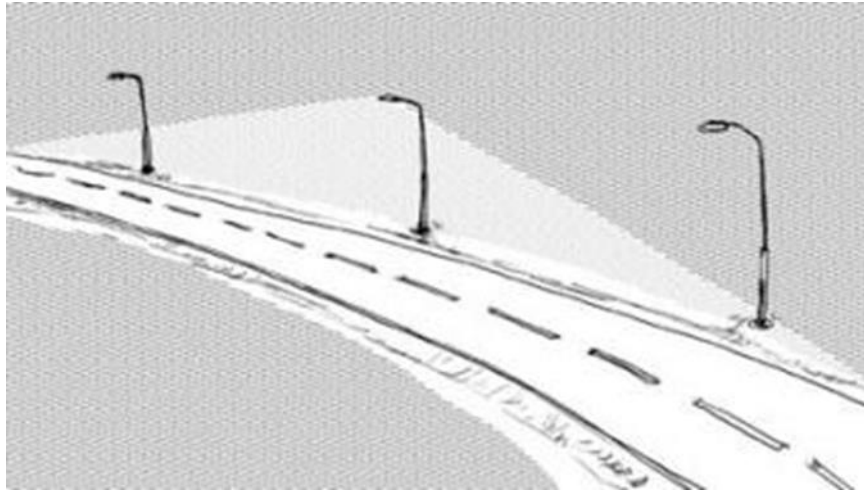

The next few slides will explain how to estimate pole layout spacing based on average illuminance. Average luminance can be calculated from the illuminance value.

The example shown on the next slide assumes a collector road as defined in the *AASHTO Roadway Lighting Design Guide*. The road has a medium classification for pedestrian conflict and asphalt pavement. Using the chart contained in the AASHTO design guide, the average maintained horizontal illuminance should be 0.9 fc (9.0 lux).

Luminaire Pole Spacing (cont'd.)
Module 3, Slide 27

The calculation for roadway luminaire pole spacing is:

$$\text{Spacing} = (\text{LL} \times \text{CU} \times \text{LLF}) / (\text{Eh} \times \text{W})$$

LL – Lamp lumens (or luminaire lumens if LED luminaire). These are initial lumens from the lamp or LED luminaire, when it is first installed.

CU – Coefficient of utilization for roadway width (use the CU table provided by the luminaire manufacturer in the photometric report of the luminaire you have selected).

LLF – Light loss factor accounts for lamp lumen depreciation and luminaire dirt depreciation

Eh – Average maintained design horizontal illuminance in footcandles (fc). In a roadway lighting design, this is the amount of light you want to provide on the pavement.

W – Width of lighted roadway in feet (ft). This is the width of the roadway this luminaire is intended to light. For example, if it is a 6-lane roadway, and the luminaire you are using is only expected to light three lanes, you only use the width of those 3 lanes.

Determine Coefficient of Utilization
Module 3, Slide 28

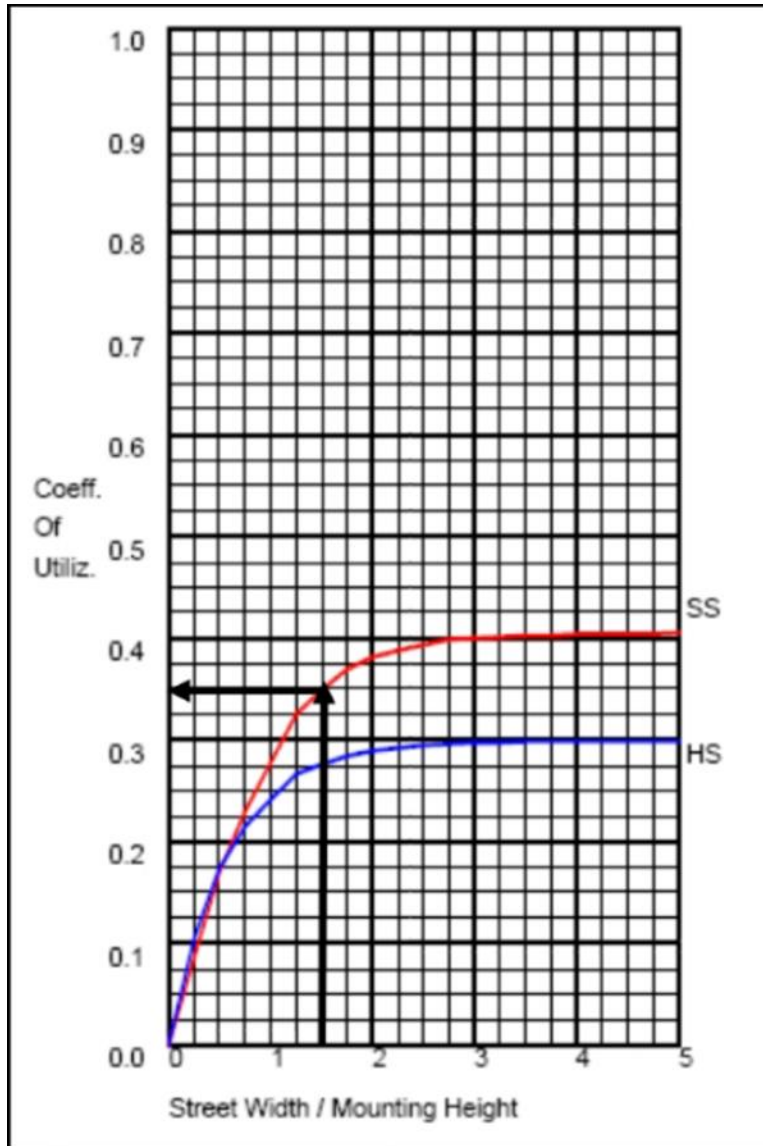

To obtain the CU, divide the width of the roadway you are lighting by the mounting height of the luminaires.

This is the ratio shown on the X axis of the CU table.

Follow this line up until you reach the CU line for street side (SS) lumens.

The intersection of this line with the CU line indicates the CU value for the roadway.

Luminaire Pole Spacing
Module 3, Slide 29

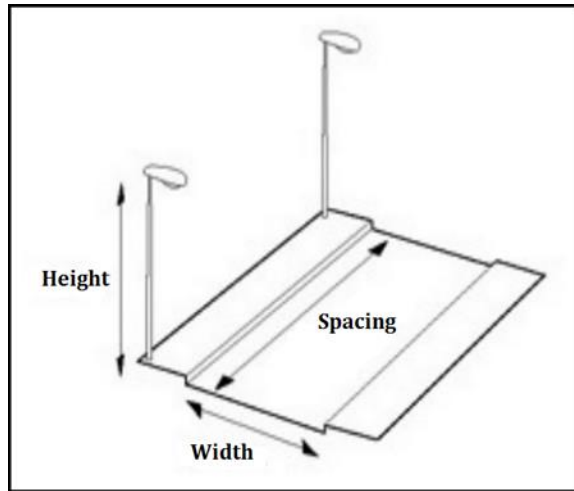

A diagram showing spacing of luminaire poles, width of lighted roadway, and mounting height of luminaires.

Luminaire Spacing Worksheet

Example		
LL	16000	lm
CU [Street Side (SS)]	0.35	
LLF	0.75	
Eh (average)	0.9	fc
W	40	ft
MH	27	ft
W/MH (40'/27')	1.5	
Spacing	117	ft

$$\begin{aligned} \text{Spacing} &= (\text{LL} \times \text{CU} \times \text{LLF}) / (\text{Eh} \times \text{W}) \\ &= (16,000 \times 0.35 \times 0.75) / (0.9 \times 40) \end{aligned}$$

Luminaire Spacing = 117 ft

Roadway Luminaire Layout
Module 3, Slide 30

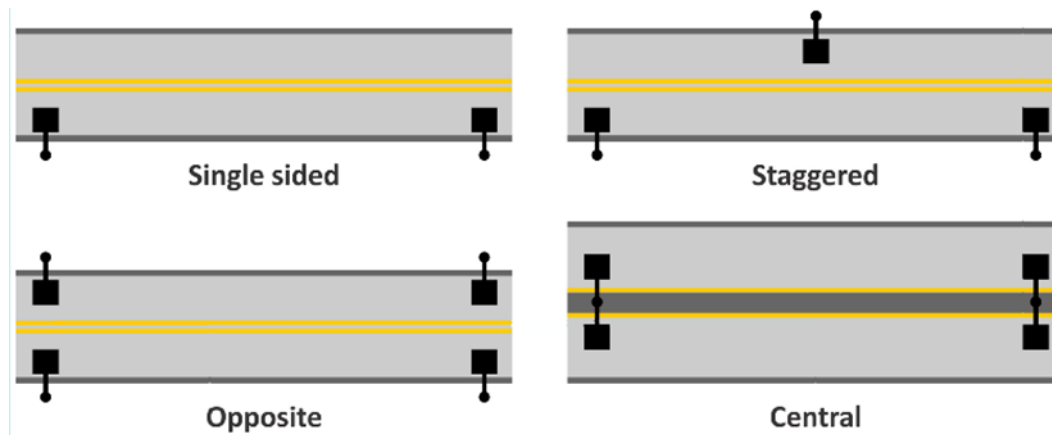

A lighting engineer has several choices of how to configure the layout of luminaires along the roadway. The pole arrangement configuration will depend, in part, upon the availability of clear space along the median or sides of the road, but mainly on the width of the road. A layout with poles along a single side of the road is best for narrower roads. Median layouts can be advantageous if there is a well-defined median and few intersections, such as along freeways. A staggered layout is appropriate for roads of medium width (about 1.5 to 2 times the pole height). Wider roads may require a two-sided layout with pole locations opposite each other along the road, in order to provide sufficient coverage.

The diagram above shows the four possible layouts of pole-mounted luminaires along a roadway.

Roadway Lighting Design Software
Module 3, Slide 31

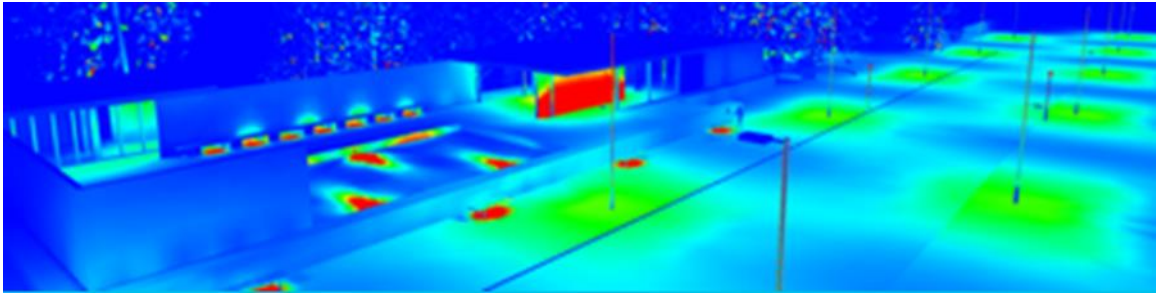

An example of a rendering produced by a lighting design software program. The colors represent different light levels from red (highest) to dark blue (lowest).

The previous two sections of this course module discussed several roadway lighting calculations. While each of these calculations can be done by hand, most often a lighting engineer will use a lighting design software program to perform these calculations and compare the overall performance of different luminaires and lighting design options.

Lighting design software is used to simulate the lighted environment in terms of spatial geometry, luminaire types, and relevant metrics, such as illuminance and luminance levels, as well as lighting uniformity. These programs produce photometrically accurate lighting calculations, and, in some cases, renderings.

Simple software packages are often free but have some design constraints.

Sophisticated software programs allow more realistic designs, like curved roadways and intersections as well as accounting for obstructions and reflections, but they can have a steep learning curve. Some programs are free; others have a moderate purchase price (\$100 – \$1000).

Simple Software Tools
Module 3, Slide 32

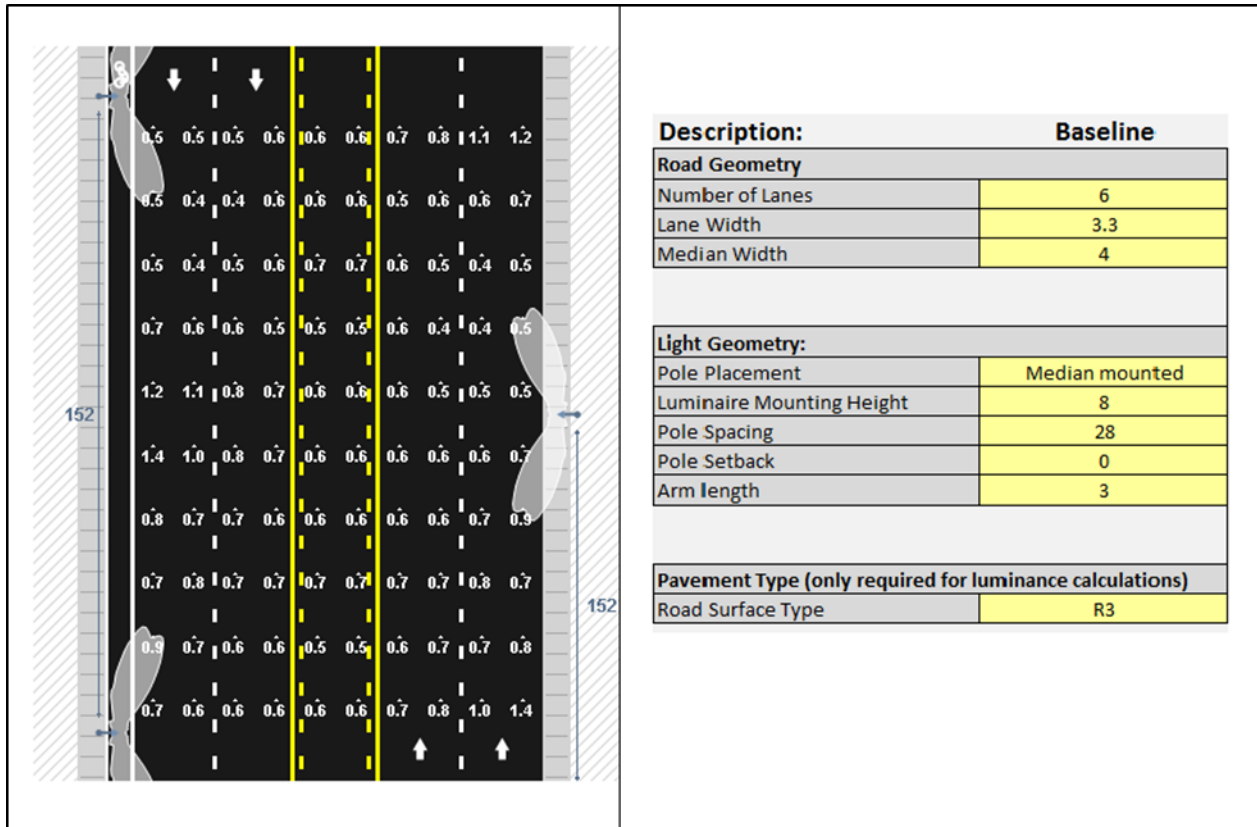

*Left: Portion of a calculation grid output display from the Visual Roadway Tool.
 Right: Part of the roadway descriptor input screen from the Street Lighting Tool.*

One simple application software program is the web-based Visual Roadway Tool courtesy of Acuity Brands lighting. It models straight segments of roadway for illuminance or luminance calculations. Another simple tool is the Street Lighting Tool from the Super-Efficient Equipment and Appliance Deployment (SEAD) Initiative.

These tools use manufacturers' photometric files. They cannot model curved roadways or intersections, and do not account for reflected light or obstructions.

They are available for free.

***Sophisticated Software Tool
Module 3, Slide 33***

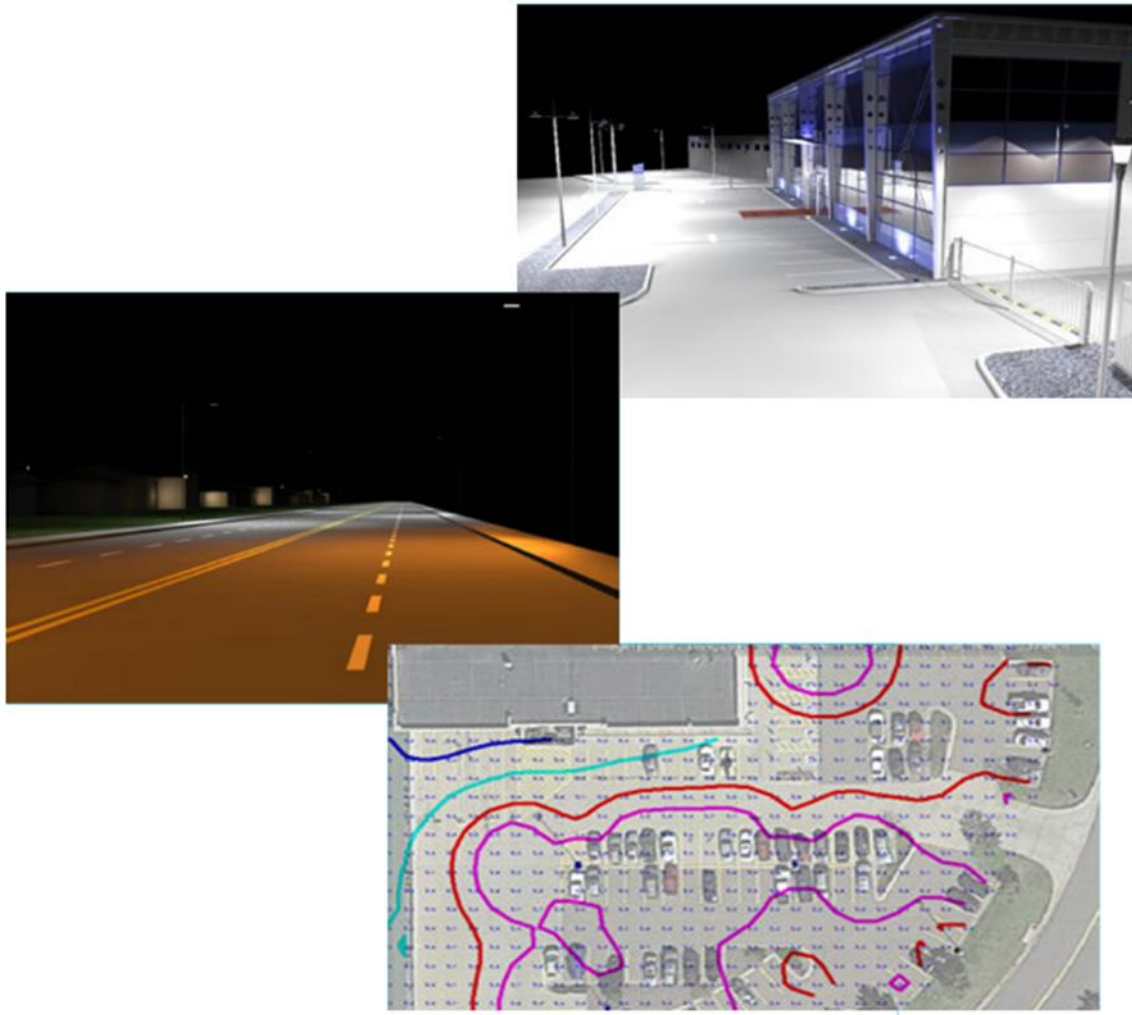

Examples of renderings produced by AGi32.

AGi32, developed and marketed by Lighting Analysts, is an example of a sophisticated software tool.

It can use any photometry and is able to model almost any outdoor environment for calculation purposes and rendering. Background images, such as satellite views, can be imported and scaled for layout purposes. The tool can also import 2D and 3D CAD files and Sketch-up files.

It has a steep learning curve, but in-person training and YouTube tutorials are available. The current cost is \$900 for a single-user license; annual support and upgrade subscriptions are available.

Knowledge Check
Module 3, Slide 34

Select the correct answer.

The coefficient of utilization (CU) is a measure of the percentage of light emitted by a luminaire that _____.

- A) is emitted in the forward direction
- B) is emitted below the luminaire
- C) reaches the roadway surface
- D) does not cause unwanted glare

Knowledge Check Answer
Module 3, Slide 35

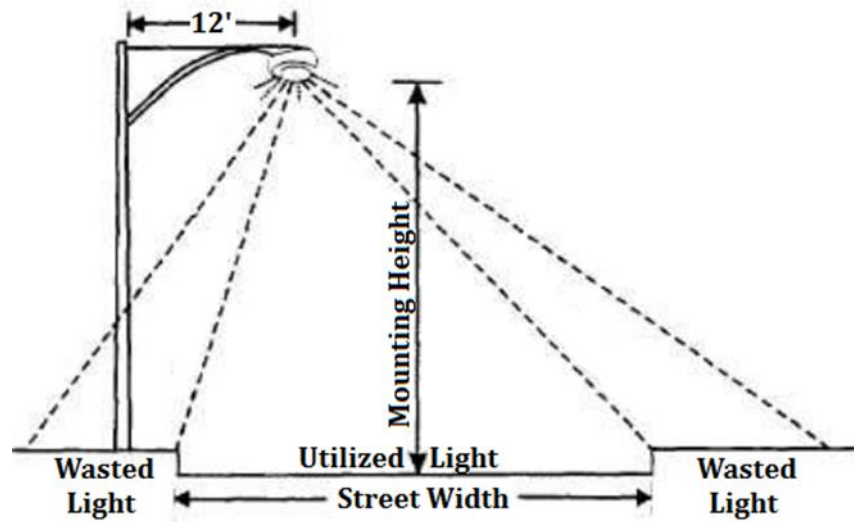

An illustration of the useful light falling on the roadway surface.

The correct answer is C.

The CU is a value between zero and one that indicates the proportion of lumens emitted by a roadway luminaire that will fall on the roadway. (See Module 3, Slide 25)

Field Measurements of Lighting
Module 3, Slide 36

This section discusses why and how to take field measurements of a roadway lighting installation.

***Why Take Field Measurements?
Module 3, Slide 37***



A busy freeway at night. Lanes would need to be closed down to take field measurements of the lighting.

There are several reasons why it is important to take field measurements of a lighting project once it has been installed, as well as over time as the system ages.

- Validate luminaire performance – ensure that the luminaires and any lighting controls are operating properly.
- Validate luminaire photometrics – ensure that the luminaires are providing the expected light output and distribution.
- Review color temperature – ensure that the color temperature (CCT) of the installation is as specified.
- Confirm that all lighting conditions (light levels, uniformity) comply with recommended practice, and design specifications.

Taking Field Measurements Module 3, Slide 38

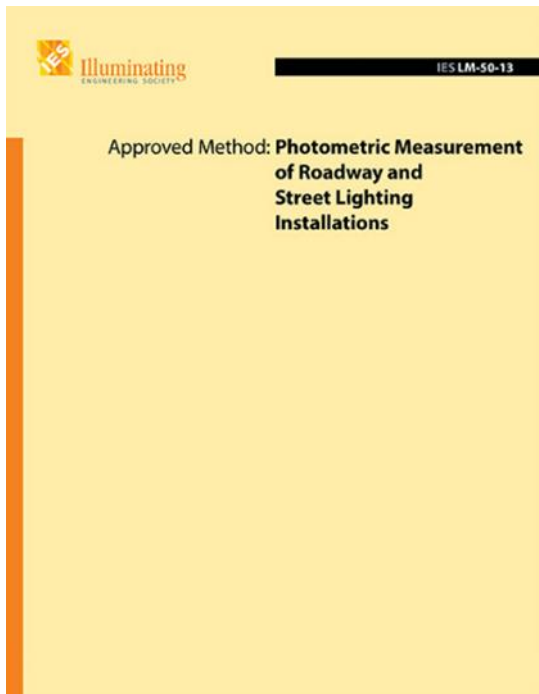

Left: IES LM-50. Right: Illuminance meter.

IES publication *Lighting Measurement Guide* number 50 (IES-LM-50) provides detailed instructions on how lighting measurements should be conducted in the field.

When taking field measurements, you must first mark off measurement grid points on the roadway, as IES-LM50 requires. Because luminance is difficult to measure, use an illuminance meter for all sections of roadway, even those designed using luminance as the design metric.

Place your illuminance meter on each of the grid points you have laid out and take a reading at each point without blocking any of the light from the luminaires. A hand-held illuminance meter with a separate sensor (as shown above) that can be placed on a movable (wheeled) platform will likely work best in this application.

Safety is very important. If you are working in traffic when taking lighting measurements, traffic control and lane closure will likely be required.

Taking Field Measurements (cont'd.)
Module 3, Slide 39

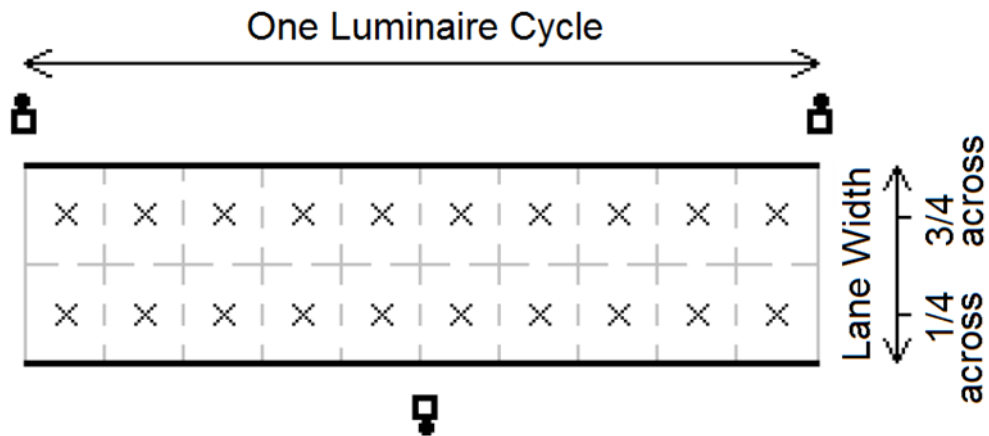

A minimum of 10 equally spaced measurement points per luminaire cycle (more if points would be more than 5 m apart)

The illustration above shows the recommended measurement points for one luminaire cycle.

At least 10 measurements must be taken per luminaire cycle. A luminaire cycle is the distance between two luminaires on one side of the roadway. These measurement points cannot be spaced more than 5 meters apart. Two lines of measurement points are needed per driving lane, one-half lane width apart.

Converting Illuminance to Luminance
Module 3, Slide 40

Once you have taken all of your illuminance measurements, you can calculate an average illuminance for the section of roadway you have measured. If it is a straight section of roadway, you will then need to convert your average illuminance measure to an average luminance value in order to check if the design meets the specifications and recommendations for the particular roadway classification.

Use the following equations for the conversion:

For asphalt roadways (R3):

$$\text{luminance (cd/m}^2\text{)} = \frac{\text{illuminance (lux)}}{15}$$

For concrete roadways (R1):

$$\text{luminance (cd/m}^2\text{)} = \frac{\text{illuminance (lux)}}{10}$$

If the average illuminance that you have measured on the roadway is 30 lux on a R3 type pavement, that would equate to a luminance of 2 cd/m².

Assess Lighting Uniformity
Module 3, Slide 41



A relatively uniform lighted stretch of roadway.

The final task you will need to perform is to check if the installation meets uniformity requirements.

You first need to determine the highest and the lowest illuminance point you measured. Compare these two points to see if the installation meets the max to min (maximum to minimum) uniformity requirements.

For example, if the maximum allowed uniformity ratio is 3 to 1, and your highest measured point was 50 lux and your lowest was 6 lux, that ratio (8.3 to 1) does not meet the requirement.

Knowledge Check
Module 3, Slide 42

Select the correct answer:

When taking illuminance measurements along a roadway the measurement points cannot be spaced farther than _____ meters apart.

- A) fifteen
- B) five
- C) ten
- D) two

Knowledge Check Answer
Module 3, Slide 43



A worker laying out a grid to take lighting measurements.

The correct answer is B, the measurement points cannot be spaced farther than five meters apart.

At least 10 measurements must be taken per luminaire cycle. A luminaire cycle is the distance between two luminaires on one side of the roadway. These measurement points cannot be spaced more than 5 meters apart. (See *Module 3, Slide 39*)

Light Pollution
Module 3, Slide 44

This section of the module will discuss various aspects of light pollution and its control.

**What is Light Pollution?
Module 3, Slide 45**

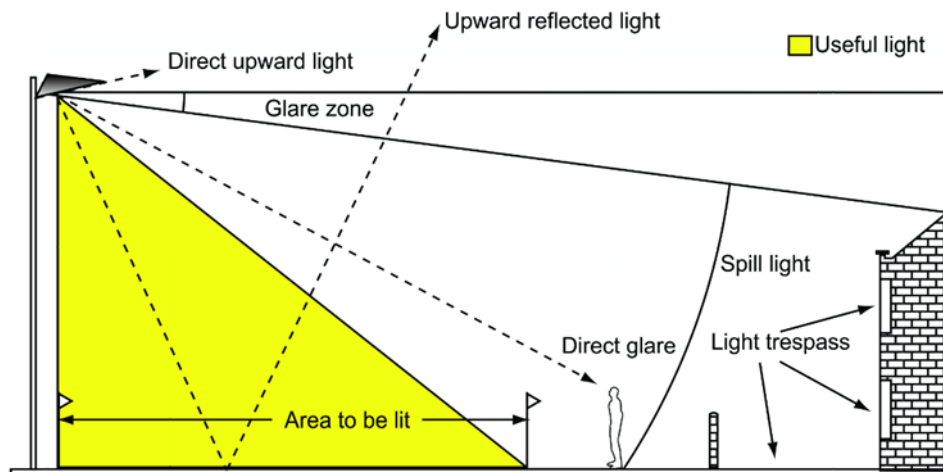

Light pollution is often caused by the way light is emitted from lighting equipment. Choosing proper equipment and carefully mounting and aiming it can make a significant difference.

Light pollution was briefly discussed in Module 2 of this course in the section on luminaire “BUG” (backlight, uplight, glare) ratings. Light pollution is an unwanted consequence of outdoor lighting and includes such effects as sky glow, light trespass, and glare. The illustration above shows both useful light and the components of light pollution. Sky glow is a brightening of the sky caused by both natural and human-made factors. The key factor of sky glow that contributes to light pollution is outdoor lighting.

***Environmental Lighting Zones
Module 3, Slide 46***



A brightly lighted area around a city. This is an example of zone four lighting.

One thing the lighting community has done to help limit light pollution is to define various environmental lighting zones (LZ). These zones help to guide lighting engineers in deciding where, when, and at what quantity to use outdoor lighting, including for roadways, streets, and parking areas. The IES publication *Technical Memorandum 11* (TM-11) defines these zones.

IES TM-11 defines five environmental lighting zones from zone zero where it recommends no outdoor lighting at night to zone four where there is relatively little restriction placed on lighting.

Local municipalities may adopt these lighting zone recommendations as part of local lighting ordinances.

Environmental Lighting Zones (cont'd.)
Module 3, Slide 47

LZ0: No ambient lighting – Areas where the natural environment will be seriously and adversely affected by lighting. An example of this zone might be near or within a national park or wildlife reserve. Roads are unlighted.

LZ1: Low ambient lighting – Areas where lighting might adversely affect flora and fauna or disturb the character of the area. This is typically a very rural area or park.

LZ2: Moderate ambient lighting – Areas of human activity where the vision of human residents and users is adapted to moderate light levels. Lighting may typically be used for safety and convenience, but it is not necessarily uniform or continuous. After curfew, lighting may be reduced as activity levels decline. This is typically a rural area, with some limited use at night.

LZ3: Moderately high ambient lighting – Areas of human activity where the vision of human residents and users is adapted to moderately high light levels. Lighting is generally desired for safety, security and/or convenience and it is often uniform and/or continuous. After curfew, lighting may be reduced as activity levels decline. This is typically a suburban area.

LZ4: High ambient lighting – Areas of human activity where the vision of human residents and users is adapted to high light levels. Lighting is generally considered necessary for safety, security and/or convenience and it is mostly uniform and/or continuous. After curfew, lighting may be reduced in some areas as activity levels decline. This is typically an urban area.

Environmental Lighting Zones (cont'd.)
Module 3, Slide 48

Designation	Recommended Maximum Illuminance Level (Ee)	
	Pre-Curfew	Post-Curfew (Not Applicable to Roadway Lighting)
LZ 1	1.0 lux	0.0 lux
LZ 2	3.0 lux	1.0 lux
LZ 3	8.0 lux	3.0 lux
LZ 4	15.0 lux	6.0 lux

The recommended maximum illuminance level for each of the lighting zones is shown above (from IES TM-11). These are shown as “pre-curfew” and “post-curfew.” Pre-curfew is from dusk until 11:00 p.m. local time, when the area being illuminated is more likely to be in use. Post-curfew is from 11:00 p.m. to 7:00 a.m. local time. Recommended lighting levels are higher during pre-curfew time.

Luminaire "BUG" Rating Module 3, Slide 49

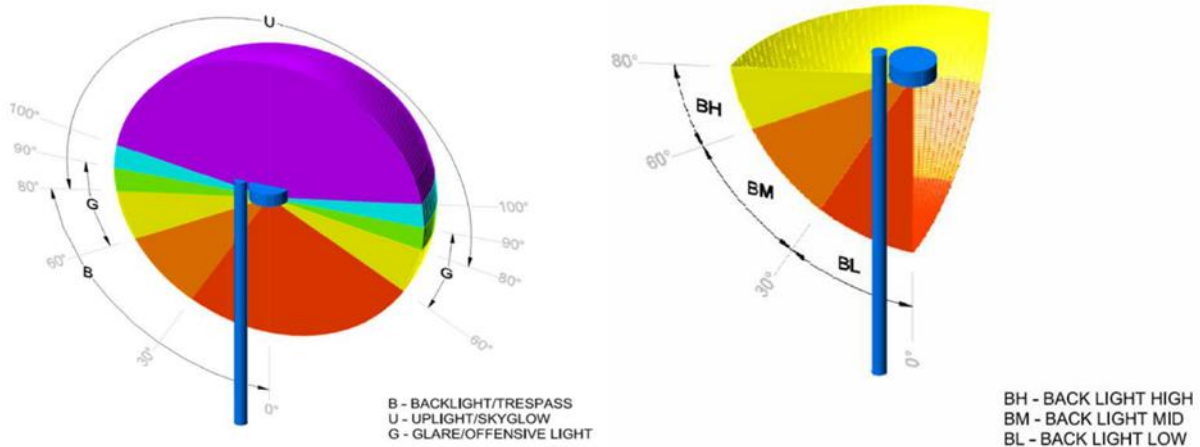

Left: Backlight, uplight and glare zones. Right: Backlight subzones.

As mentioned in Module 2 of this course, one way to help limit light pollution is to select a luminaire that does not send light into areas where it is not needed, for example behind the luminaire off of the roadway (backlight), directly up into the sky (uplight), and light at high angles (likely to cause glare for drivers and pedestrians).

For most roadway luminaires, there should be little or no light emitted in the zones "G" (glare) or zone "U" (uplight), shown in the illustration on the top at left. This will limit both glare and sky glow.

For the luminaire shown in the illustration above at right, if you wanted to light a sidewalk along the roadway, you might select a luminaire that distributes some light in zone "BL" (back lower). However if you wanted to limit light going beyond that point, you would select a luminaire with little or no light in zones "BM" (back middle), or "BH" (back high). This would limit light trespass off the roadway or street.

Local outdoor lighting ordinances will typically place limits on the amount of light allowed in each zone, not directly lighting the roadway.

Outdoor Site-Lighting Performance Module 3, Slide 50

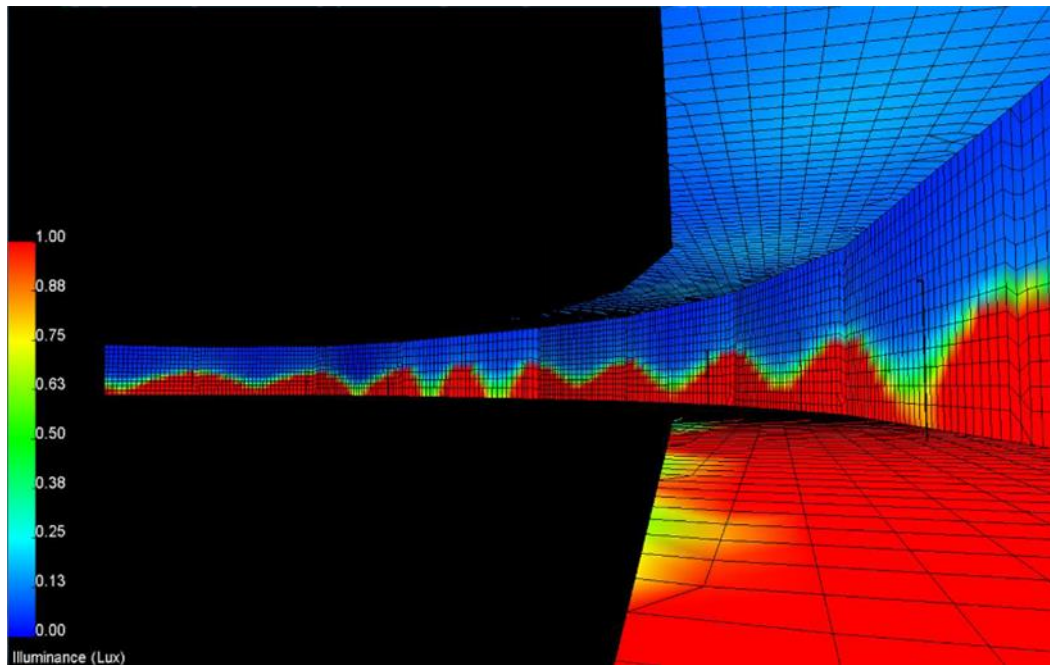

A computer rendering showing useful light on the horizontal roadway surface, light leaving the vertical surface (light trespass) and light leaving the horizontal surface above the road, which contributes to sky glow. Each color represents a light (lux) level (see legend at the left of the image).

A luminaire “BUG” rating is a good tool to limit direct light from a luminaire going where it is unwanted. However, a major contributor to light pollution is light that is reflected off the roadway and adjacent areas (e.g. walkways along the road).

The metric called Outdoor Site-Lighting Performance (OSP) was developed to capture the contribution that both direct and reflected light make to light pollution.

OSP is not a luminaire-based metric, it is a design metric. It allows a lighting engineer to compare various designs using commercially available lighting software. With OSP a “box” is constructed in the lighting software program along each side and over the roadway. This box allows the software program to measure all of the light leaving the roadway, both directly and reflected.

For more information on using the OSP metric, follow the link at the end of this course module.

**Outdoor Site-Lighting Performance (cont'd.)
Module 3, Slide 51**

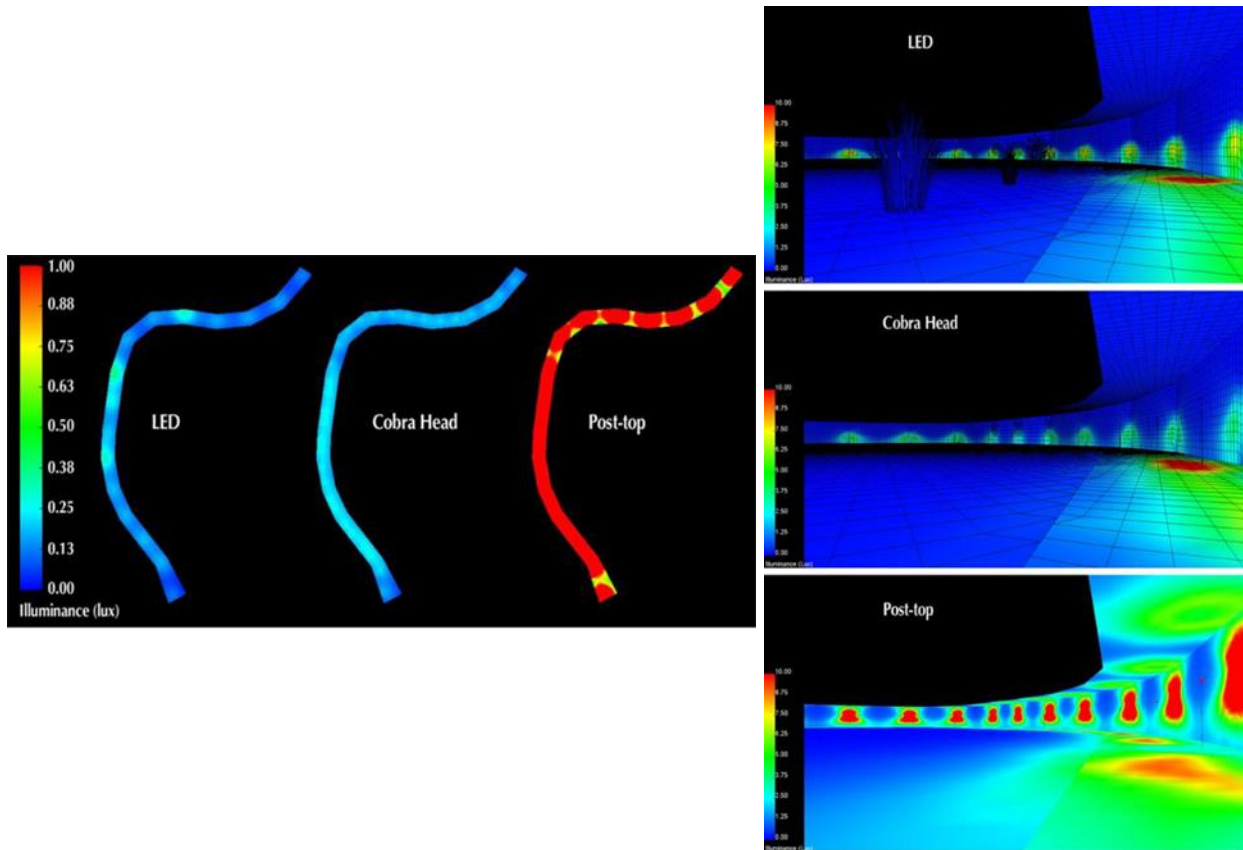

Left: A computer rendering (plan view) showing light leaving the roadway up into the sky. Right: A computer rendering (perspective view) showing light leaving the sides of the roadway. Colors correspond to light (lux) level.

These images show a comparison of three lighting design options for a roadway, LED luminaires, cobra-head luminaires with high pressure sodium (HPS) lamps, and post-top luminaires. The images above at right show the amount of light trespass; the image above at left shows the installations contribution to sky glow.

In all cases, the LED luminaire contributes the least to light pollution (sky glow and light trespass), while the post top contributes the most.

Knowledge Check
Module 3, Slide 52

True or false:

A roadway in environmental lighting zone one, should be lighted to a higher level than a roadway in zone four.

- A) True
- B) False

Knowledge Check Answer
Module 3, Slide 53



An aerial view of nighttime lighting across the globe.

The correct answer is “false.”

Environmental lighting zone 1 should have the lowest amount of electric lighting on the roadway, while zone 4 allows for the highest electric lighting levels.

Self-Assessment Quiz
Module 3, Slides 54 to 63

Please answer each question.

1. Illuminance is _____ proportional to the square of the distance between the luminaire and the surface being illuminated.
 - a. Directly
 - b. Inversely
2. The luminance of a road surface is based on:
 - a. The illuminance of the road surface
 - b. The geometry of the installation
 - c. The reflection characteristics of the pavement
 - d. The location of the observer
 - e. All of the above
3. True or false? Diffuse reflection occurs when a rough roadway surface causes reflected rays of light to travel in different directions.
 - a. True
 - b. False
4. Veiling luminance is used as a measure of the _____ produced by roadway luminaires.
 - a. Amount of light
 - b. Sky glow
 - c. Glare
 - d. Overall roadway illuminance
5. If the required illuminance uniformity ratio for a stretch of roadway is 4 to 1, and the highest illuminance you measure on the roadway surface is 12 lux, and the lowest is 4 lux, does this roadway meet this uniformity requirement?
 - a. Yes
 - b. No
6. For a stretch of freeway 150 meters long, with luminaire mounting heights of 5 meters, you have installed luminaires with a lamp lumen depreciation factor of 0.84 and a luminaire dirt depreciation factor of 0.89. What would the total light loss factor be for the luminaires used in this installation?
 - a. 1.73
 - b. 0.75
 - c. 526.5
 - d. 3.75
7. What is the most important factor in selecting between a single sided luminaire layout and an opposite side layout?
 - a. The mounting height of the luminaires
 - b. Traffic volume along the roadway
 - c. The width of the roadway
 - d. The amount of pedestrian conflict along the roadway

Self-Assessment Quiz (cont'd.)
Module 3, Slides 54 to 63

8. True or false? Only light directly emitted by luminaires, and not reflected light, contributes to light pollution.
- a. True
 - b. False

See the following page for the answer key to this self-assessment.

Self-Assessment Quiz Answer Key
Module 3, Slides 54 to 63

The correct answers for the self-assessment are provided below.

1. Illuminance is _____ proportional to the square of the distance between the luminaire and the surface being illuminated.
 - a. Directly
 - b. Inversely (See Module 3, Slide 6)
2. The luminance of a road surface is based on:
 - a. The illuminance of the road surface
 - b. The geometry of the installation
 - c. The reflection characteristics of the pavement
 - d. The location of the observer
 - e. All of the above (See Module 3, Slide 9)
3. True or false? Diffuse reflection occurs when a rough roadway surface causes reflected rays of light to travel in different directions.
 - a. True (See Module 3, Slide 10)
 - b. False
4. Veiling luminance is used as a measure of the _____ produced by roadway luminaires.
 - a. Amount of light
 - b. Sky glow
 - c. Glare (See Module 3, Slide 12)
 - d. Overall roadway illuminance
5. If the required illuminance uniformity ratio for a stretch of roadway is 4 to 1, and the highest illuminance you measure on the roadway surface is 12 lux, and the lowest is 4 lux, does this roadway meet this uniformity requirement?
 - a. Yes (See Module 3, Slide 14)
 - b. No
6. For a stretch of freeway 150 meters long, with luminaire mounting heights of 5 meters, you have installed luminaires with a lamp lumen depreciation factor of 0.84 and a luminaire dirt depreciation factor of 0.89. What would the total light loss factor be for the luminaires used in this installation?
 - a. 1.73
 - b. 0.75 (See Module 3, Slide 23)
 - c. 526.5
 - d. 3.75
7. What is the most important factor in selecting between a single sided luminaire layout and an opposite side layout?
 - a. The mounting height of the luminaires
 - b. Traffic volume along the roadway
 - c. The width of the roadway (See Module 3, Slide 30)
 - d. The amount of pedestrian conflict along the roadway

Self-Assessment Quiz Answer (cont'd.)
Module 3, Slides 54 to 63

8. True or false? Only light directly emitted by luminaires, and not reflected light, contributes to light pollution.
- a. True
 - b. False (*See Module 3, Slide 50*)

Extended Example Problem

Suppose a luminaire to illuminate an asphalt 60-foot-wide collector road with high pedestrian conflict (average luminance criterion 0.8 cd/m^2 , with an equivalent average horizontal illuminance of 12 lux or 1.2 footcandles) produces 50,000 lumens. It has a mounting height of 40 feet. The lamp lumen depreciation for the luminaire you are using is 0.8 and the luminaire dirt depreciation for the environment is 0.9.

Step 1: Enter the lamp lumens (LL), average horizontal illuminance (Eh), roadway width (W) and mounting height (MH) into the table on the following page.

Step 2: Determine the width/mounting height (W/MH) ratio and enter it into the table on the following page.

Step 3: Use the chart below to determine the coefficient of utilization (CU) and enter it into the table on the following page.

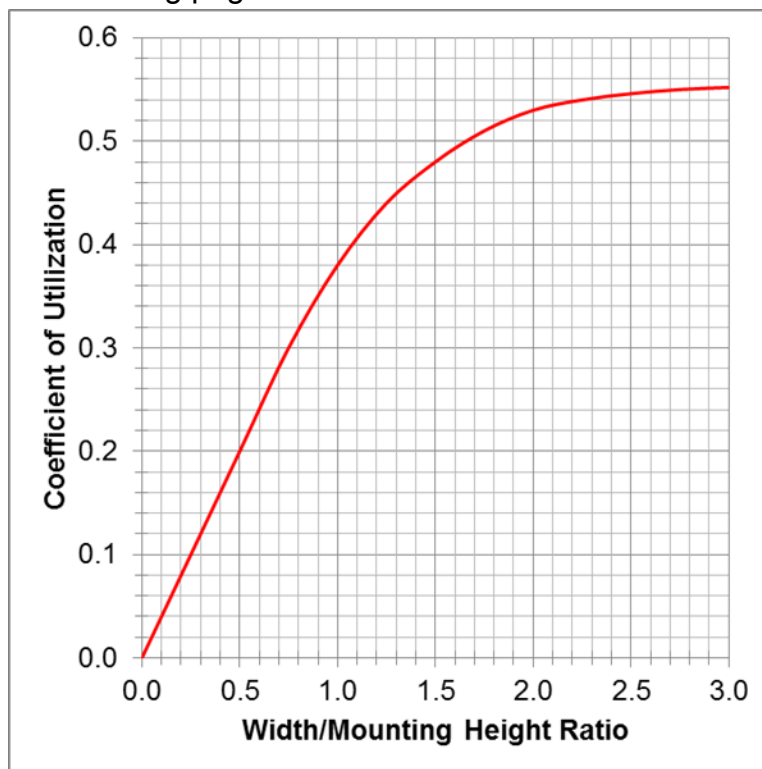

Step 4: Determine the light loss factor (LLF) and enter it into the table on the following page.

Step 5: Calculate the spacing and enter it into the table on the following page.

Extended Example Problem (Continued)

Extended Problem		
LL		lm
CU [Street Side (SS)]		
LLF		
Eh (average)		fc
W		ft
MH		ft
W/MH		
Spacing		ft

See the following page for the answer to this extended example problem.

Extended Example Problem (Answer Key)

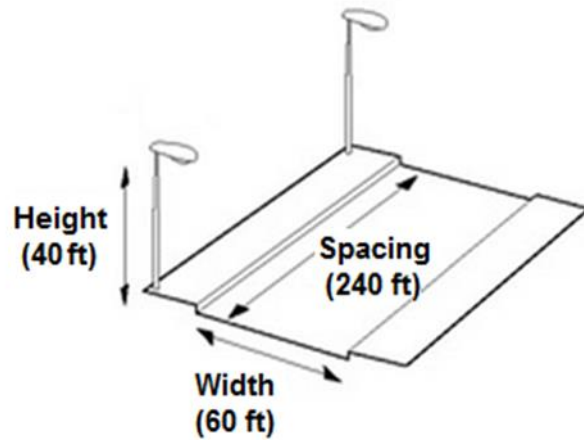

Extended Problem

LL	50,000	lm
CU [Street Side (SS)]	0.48	
LLF	0.72	
Eh (average)	1.2	fc
W	60	ft
MH	40	ft
W/MH	1.5	
Spacing	240	ft

Step 1: LL = 50,000 lm; Eh = 1.2 fc, W = 60 ft, MH = 40 ft.

Step 2: W/MH = (60 ft) / (40 ft) = 1.5.

Step 3: According to the CU chart, the CU for a W/MH value of 1.5 is **0.48**.

Step 4: LLF = LLD x LDD = 0.8 x 0.9 = **0.72**.

Step 5: Spacing = (LL x CU x LLF) / (Eh x W)
 = (50,000 x 0.48 x 0.72) / (1.2 x 60)
 = **240 ft.**

Links to Other Resources
Module 3, Slide 64

FHWA Lighting Handbook

https://safety.fhwa.dot.gov/roadway_dept/night_visib/lighting_handbook

IES RP-8 Roadway Lighting

<https://www.ies.org/store/recommended-practices-and-ansi-standards/roadway-lighting>

IES LM-50 Measurement of Roadway and Street Lighting Installations

<https://www.ies.org/store/measurement-testing/photometric-measurement-of-roadway-and-street-lighting-installations/>

Acuity Visual Roadway Lighting Design Tool

<https://www.visual-3d.com/software/roadwaytool.aspx>

SEAD Street Lighting Tool

<http://www.superefficient.org/Tools/Street-Lighting-Tool>

AGi32 Lighting Design Software

<http://www.agi32.com/>

IES TM-10 Addressing Obtrusive Light in Conjunction with Roadway Lighting

<https://www.ies.org/store/technical-memoranda/addressing-obtrusive-light-urban-sky-glow-and-light-trespass-in-conjunction-with-roadway-lighting/>

Outdoor Site-Lighting Performance Metric

http://www.lrc.rpi.edu/researchAreas/pdf/instructions_for_building_OSP_box.pdf

AASHTO Roadway Lighting Design Guide

https://bookstore.transportation.org/item_details.aspx?ID=1412

Credits
Module 3, Slide 66

Slide 10: Image courtesy of Virginia Tech Transportation Institute, WSP Global Inc., and DMD & Associates Ltd.

Slide 11: Table courtesy of Virginia Tech Transportation Institute, WSP Global Inc., and DMD & Associates Ltd.

Slide 46: Photograph courtesy of Virginia Tech Transportation Institute, WSP Global Inc., and DMD & Associates Ltd.

All other images taken from U.S. Government publications or are released to the public domain by the module authors.