



U.S. Department  
of Transportation  
**Federal Highway  
Administration**

SEP 17 2018

1200 New Jersey Ave., SE  
Washington, D.C. 20590

In Reply Refer To:  
HSST-1 / B-306

Mr. Casey McMaster  
Saferoads Pty Ltd  
22 Commercial Drive Pakenham 3810 Victoria  
Australia

Dear Mr. McMaster:

This letter is in response to your June 25, 2018 request for the Federal Highway Administration (FHWA) to review a roadside safety device, hardware, or system for eligibility for reimbursement under the Federal-aid highway program. This FHWA letter of eligibility is assigned FHWA control number B-306 and is valid until a subsequent letter is issued by FHWA that expressly references this device.

### **Decision**

The following device is eligible within the length-of-need, with details provided in the form which is attached as an integral part of this letter:

- HV2 Transition to Crash Cushion

### **Scope of this Letter**

To be found eligible for Federal-aid funding, new roadside safety devices should meet the crash test and evaluation criteria contained in the American Association of State Highway and Transportation Officials' (AASHTO) Manual for Assessing Safety Hardware (MASH). However, the FHWA, the Department of Transportation, and the United States Government do not regulate the manufacture of roadside safety devices. Eligibility for reimbursement under the Federal-aid highway program does not establish approval, certification or endorsement of the device for any particular purpose or use.

This letter is not a determination by the FHWA, the Department of Transportation, or the United States Government that a vehicle crash involving the device will result in any particular outcome, nor is it a guarantee of the in-service performance of this device. Proper manufacturing, installation, and maintenance are required in order for this device to function as tested.

This finding of eligibility is limited to the crashworthiness of the system and does not cover other structural features, nor conformity with the Manual on Uniform Traffic Control Devices.

### **Eligibility for Reimbursement**

Based solely on a review of crash test results and certifications submitted by the manufacturer, and the crash test laboratory, FHWA agrees that the device described herein meets the crash test and evaluation criteria of the AASHTO's MASH. Therefore, the device is eligible for reimbursement under the Federal-aid highway program if installed under the range of tested conditions.

Name of system: HV2 Transition to Crash Cushion I

Type of system: Transition

Test Level: MASH Test Level 3 (TL3)

Testing conducted by: Holmes Solutions LP

Date of request: June 25, 2018

Date initially acknowledged: June 30, 2018

FHWA concurs with the recommendation of the accredited crash testing laboratory on the attached form.

### **Full Description of the Eligible Device**

The device and supporting documentation, including reports of the crash tests or other testing done, videos of any crash testing, and/or drawings of the device, are described in the attached form.

### **Notice**

This eligibility letter is issued for the subject device as tested. Modifications made to the device are not covered by this letter. Any modifications to this device should be submitted to the user (i.e., state DOT) as per their requirements.

You are expected to supply potential users with sufficient information on design, installation and maintenance requirements to ensure proper performance.

You are expected to certify to potential users that the hardware furnished has the same chemistry, mechanical properties, and geometry as that submitted for review, and that it will meet the test and evaluation criteria of AASHTO's MASH.

Issuance of this letter does not convey property rights of any sort or any exclusive privilege. This letter is based on the premise that information and reports submitted by you are accurate and correct. We reserve the right to modify or revoke this letter if: (1) there are any inaccuracies in the information submitted in support of your request for this letter, (2) the qualification testing was flawed, (3) in-service performance or other information reveals safety problems, (4) the system is significantly different from the version that was crash tested, or (5) any other information indicates that the letter was issued in error or otherwise does not reflect full and complete information about the crashworthiness of the system.

**Standard Provisions**

- To prevent misunderstanding by others, this letter of eligibility designated as FHWA control number B-306 shall not be reproduced except in full. This letter and the test documentation upon which it is based are public information. All such letters and documentation may be reviewed upon request.
  
- This letter shall not be construed as authorization or consent by the FHWA to use, manufacture, or sell any patented system for which the applicant is not the patent holder.
  
- This FHWA eligibility letter is not an expression of any Agency view, position, or determination of validity, scope, or ownership of any intellectual property rights to a specific device or design. Further, this letter does not impute any distribution or licensing rights to the requester. This FHWA eligibility letter determination is made based solely on the crash-testing information submitted by the requester. The FHWA reserves the right to review and revoke an earlier eligibility determination after receipt of subsequent information related to crash testing.
  
- If the subject device is a patented product it may be considered to be proprietary. If proprietary systems are specified by a highway agency for use on Federal-aid projects: (a) they must be supplied through competitive bidding with equally suitable unpatented items; (b) the highway agency must certify that they are essential for synchronization with the existing highway facilities or that no equally suitable alternative exists; or (c) they must be used for research or for a distinctive type of construction on relatively short sections of road for experimental purposes. Our regulations concerning proprietary products are contained in Title 23, Code of Federal Regulations, Section 635.411.

Sincerely,



Michael S. Griffith  
Director, Office of Safety Technologies  
Office of Safety

Enclosures

## Request for Federal Aid Reimbursement Eligibility of Highway Safety Hardware

<b>Submitter</b>	Date of Request:	June 29, 2018	<input checked="" type="radio"/> New <input type="radio"/> Resubmission
	Name:	Casey McMaster	
	Company:	Saferoads Pty Ltd	
	Address:	22 Commercial Drive Pakenham 3810 Victoria	
	Country:	Australia	
	To:	Michael S. Griffith, Director FHWA, Office of Safety Technologies	

I request the following devices be considered eligible for reimbursement under the Federal-aid highway program.

**Device & Testing Criterion** - Enter from right to left starting with Test Level

!-!-!

System Type	Submission Type	Device Name / Variant	Testing Criterion	Test Level
'B': Rigid/Semi-Rigid Barriers (Roadside, Median, Bridge Railings)	<input checked="" type="radio"/> Physical Crash Testing <input type="radio"/> Engineering Analysis	HV2 Transition to Crash Cushion	AASHTO MASH	TL3

By submitting this request for review and evaluation by the Federal Highway Administration, I certify that the product(s) was (were) tested in conformity with the AASHTO Manual for Assessing Safety Hardware and that the evaluation results meet the appropriate evaluation criteria in the MASH.

**Individual or Organization responsible for the product:**

Contact Name:	Casey McMaster	Same as Submitter <input checked="" type="checkbox"/>
Company Name:	Saferoads Pty Ltd	Same as Submitter <input checked="" type="checkbox"/>
Address:	22 Commercial Drive Pakenham 3810 Victoria	Same as Submitter <input checked="" type="checkbox"/>
Country:	Australia	Same as Submitter <input checked="" type="checkbox"/>
Enter below all disclosures of financial interests as required by the FHWA 'Federal-Aid Reimbursement Eligibility Process for Safety Hardware Devices' document.		
Saferoads Pty. Ltd. and Holmes Solutions share no financial interests in the HV2 Barrier or HV2 Transition to Crash Cushion either by Holmes Solutions or between the two organizations, other than the costs involved in the actual crash tests and reports for this submission to FHWA.		
This includes no shared financial interests but not limited to:		
i. Compensation included wages, salaries, commissions, professional fees, or fees for business referrals		
ii. Research funding or other forms of research support		
iii. Patents, copyrights, licenses, and other intellectual property interests		
iv. Business ownership and investment interest.		

## PRODUCT DESCRIPTION

- New Hardware or Significant Modification     
  Modification to Existing Hardware

The HV2 Transition is designed to transition the HV2 Longitudinal Barrier to a pinned Crash Cushion. The Transition has been tested to TL-3 (100 km/h-62 m/h) at 25 degrees for the reverse impact into the rear of the Crash Cushion at the Critical Impact Point (Coffin Corner). The Transition is designed to redirect and shield vehicles from roadside obstacles while providing positive protection and separation between the traveling public and the personnel in the work zone. The Transition ensures the rear of the Crash Cushion does not snag or pocket the impacting vehicle and the evaluation criteria in MASH for test 3-21 are within acceptable limits.

The Transition comprises a 10mm (0.39inch) steel baseplate measuring 1,900mm (74.8inch) long x 1,067mm (42inch) wide that has a series of 24mm holes for the chemical ground anchors to be installed. Welded to the baseplate is a welded body section, that connects to the transition Fender panels that have a similar cross section to fit into the Crash Cushion fender panels. Also welded to the body section is the knuckle connector for attachment to the HV2 barrier segments. The HV2 Barrier connects to one end by sliding the standard connectors together, the crash cushion is bolted to the other end. Below the HV2 connector there are two 32mm (1.26inch) thick plates welded to the transitions face to reduce the rotation of the barriers during impact. The overall length is 2,552mm (100.5inch) and height is 900mm (35.4inch). Square Hollow Section (SHS) bracing is provided horizontally between the side panels for extra stiffness. The transition is chemically anchored to the ground using M20 x 460mm (3/4inch x 18inch) threaded Rod sections. The foundation used in the test is 150mm 5.9inch asphalt over 150mm (5.9inch) compacted sub base. The crash cushion was installed using the same Chemical anchors. The transition can also be installed on concrete pavements.

The Transition anchors the HV2 barrier to the ground enabling the system to redirect from the Beginning Length of Need of the Crash Cushion. Unlike the HV2 Barrier, the Transition does not require concrete ballast as it is pinned to the pavement.

## CRASH TESTING

By signature below, the Engineer affiliated with the testing laboratory, agrees in support of this submission that all of the critical and relevant crash tests for this device listed above were conducted to meet the MASH test criteria. The Engineer has determined that no other crash tests are necessary to determine the device meets the MASH criteria.

Engineer Name:	Emerson Ryder	
Engineer Signature:	<b>Emerson Ryder</b>	Digitally signed by Emerson Ryder Date: 2018.06.29 10:38:28 +12'00'
Address:	254 Montreal Street Christchurch	Same as Submitter <input type="checkbox"/>
Country:	New Zealand	Same as Submitter <input type="checkbox"/>

A brief description of each crash test and its result:

Required Test Number	Narrative Description	Evaluation Results
3-10 (1100C)	The Length of Need Test is not required for Transitions. Note this test was conducted on the HV2 Longitudinal Barrier sections and submitted separately.	Non-Relevant Test, not conducted
3-11 (2270P)	The Length of Need Test is not required for Transitions. Note this test was conducted on the HV2 Longitudinal Barrier sections and submitted separately.	Non-Relevant Test, not conducted

Required Test Number	Narrative Description	Evaluation Results
3-20 (1100C)	Optional Test 3-20 was not conducted as there was no reasonable uncertainty regarding the occupant risk and post-impact trajectory for small passenger vehicles.	Non-Critical, not conducted
3-21 (2270P)	<p>MASH 3-21 (Holmes NZ) Test No. 132266.3-21            Test Date - May 24th, 2018            Test Report No. 132266.01            The HV2 steel temporary barrier Transition when connected on one end to a Crash Cushion and the other end to HV2 Barriers successfully contained and redirected the 2012 model Dodge Ram impacting the test article at 24.7 degrees and a velocity of 98.0km/h (60.9m/h) at the Critical Impact Point. The Dynamic deflection was 0.21m (8.3inches)</p> <p>The vehicle did not penetrate, underide or override the installation. No detached elements, fragments, or other debris were present to penetrate or show potential for penetrating the occupant compartment, or to present undue hazard to others in the area. Maximum occupant compartment deformation was 185mm (7.3inches). The vehicle remained upright during and after the collision event. Maximum roll and pitch angles were 26.5° and 12.5° respectively. Occupant Risk factors were all within the preferred limits specified in MASH.</p>	PASS

Full Scale Crash Testing was done in compliance with MASH by the following accredited crash test laboratory (cite the laboratory's accreditation status as noted in the crash test reports.):

Laboratory Name:	Holmes Solutions LP	
Laboratory Signature:	<b>Emerson Ryder</b>	Digitally signed by Emerson Ryder Date: 2018.06.29 10:40:04 +12'00'
Address:	254 Montreal Street Christchurch	Same as Submitter <input type="checkbox"/>
Country:	New Zealand	Same as Submitter <input type="checkbox"/>
Accreditation Certificate Number and Dates of current Accreditation period :	ISO/IEC 17025:2005;IANZ Certificate Number;1022 23 July 2009 to Present Day	

Submitter Signature\*: Casey McMaster

Digitally signed by Casey  
McMaster  
Date: 2018.06.29 09:29:16 +10'00'

Submit Form

### ATTACHMENTS

Attach to this form:

- 1) Additional disclosures of related financial interest as indicated above.
- 2) A copy of the full test report, video, and a Test Data Summary Sheet for each test conducted in support of this request.
- 3) A drawing or drawings of the device(s) that conform to the Task Force-13 Drawing Specifications [[Hardware Guide Drawing Standards](#)]. For proprietary products, a single isometric line drawing is usually acceptable to illustrate the product, with detailed specifications, intended use, and contact information provided on the reverse. Additional drawings (not in TF-13 format) showing details that are relevant to understanding the dimensions and performance of the device should also be submitted to facilitate our review.

FHWA Official Business Only:

Eligibility Letter		Key Words
Number	Date	

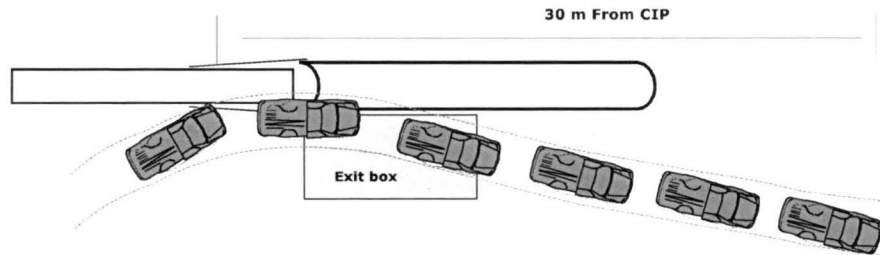

<b>Test Article:</b>	Safe Roads Transition to Crash Cushion	<b>Post Impact Vehicle Behaviour</b>	
<b>Total Length</b>	55.4 m	Vehicle Stability	Good
<b>Key Elements - Barrier</b>	3-21 (Reverse Impact)	Stopping Distance	30.0 m
Description	Steel Temporary Barrier System	<b>Vehicle Snagging</b>	None
Length of Barrier Installation	46.4 m length of need including Transition Length of 1.9 m	<b>Vehicle Pocketing</b>	None
Height	0.90 m	<b>Occupant Impact Velocity (m/s)</b>	0.0991 seconds left side of interior
Length of Barrier Segments	5.8 m	Longitudinal	6.0
<b>Test Vehicle</b>		Lateral (optional)	- 8.5
Designation	2270P	<b>Occupant Ride-down Deceleration</b>	
Make/Model	Dodge Ram 1500 Quad Cab	X-direction (g)	-11.2 [0.0990 - 0.1090 seconds]
Dimensions (LxWxH)	5675 mm x 1990 mm x 1910 mm	Y-direction (g)	12.7 [0.2181 - 0.2281 seconds]
Curb Wt	2270.5 kg	THIV (optional) (m/s)	10.3
Test Inertial Wt	2261.5 kg	PHD (optional) (g)	19.5 [0.0957 - 0.1057 seconds]
Gross Static	2261.5 kg	ASI (optional)	1.69 [0.0536 - 0.1036 seconds]
<b>Impact Conditions</b>		<b>Test Article Damage</b>	Moderate
Speed	98.0 km /h	<b>Test Article Deflections</b>	
Angle	24.7 degrees	Dynamic	0.21 m [0.68 ft.]
Impact Point	1.38 m Upstream of Transition Joint 8B and 9A	Permanent	0.21 m [0.68 ft.]
<b>Exit Conditions</b>		Working Width	1.22 m [4.00 ft.]
Exit Speed:	79 km/h	<b>Vehicle Damage Exterior</b>	
Exit Angle:	18.0° Est	VDS	11FL-4
<b>Test Number</b>	132266.3-21	CDC	11LFEE4
<b>Test Date</b>	24 May 2018	Maximum Deformation	185 mm



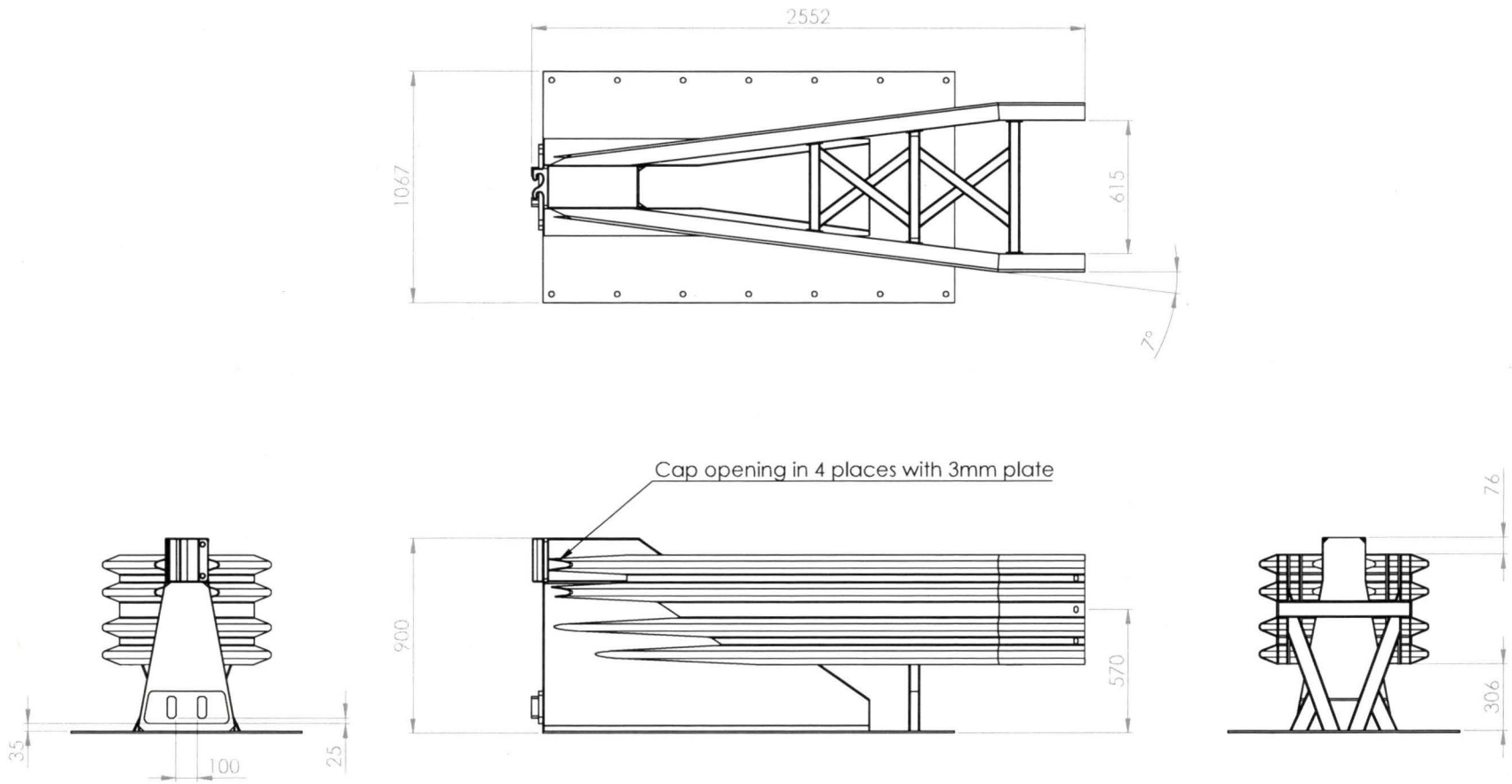

© THE DESIGN IS THE PROPERTY OF SAFEROADS. IT MUST NOT BE COPIED OR REPRODUCED WITHOUT THE SPECIFIC WRITTEN PERMISSION OF SAFEROADS PTY. LTD. UNLESS OTHERWISE SPECIFIED. ALL DIMENSIONS ARE IN mm. DO NOT SCALE DRAWING. DRAFTING STANDARD IS TO AS 1100. REFER TO SRP000001 FOR TOLERANCES AND SPECIFICATIONS.

THIRD ANGLE PROJECTION



A3

SCALE: 1:20

SHEET 1 of 3

OSTENDO Code

Drawn	Material
App'd	Finish Galvanised
	Weight 450.2 kg



Title QuadGuard Transition

Drawing Number SRA000119

Revision A

ONLY BRACING SHOWN FOR CLARITY

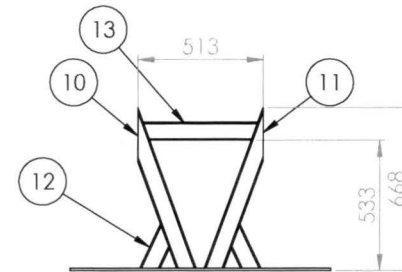
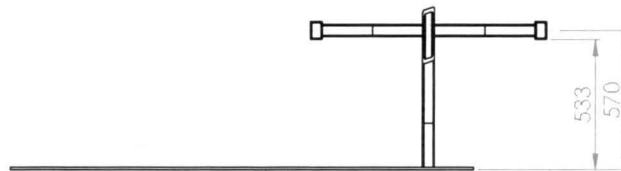
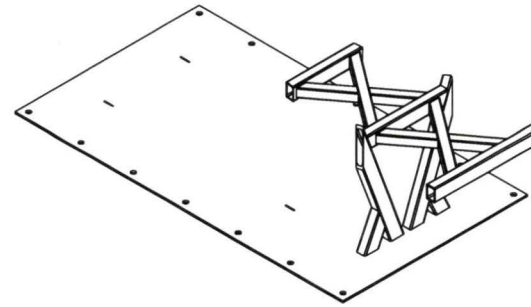
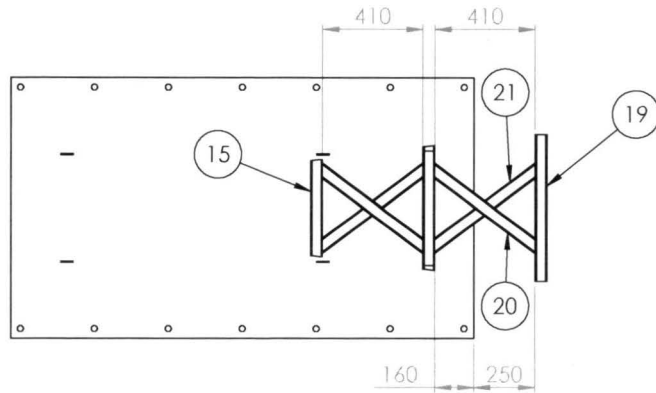

ONLY UPRIGHT BRACING SHOWN FOR CLARITY

<small>© THIS DESIGN IS THE PROPERTY OF SAFEROADS. IT MUST NOT BE COPIED OR REPRODUCED WITHOUT THE SPECIFIC WRITTEN PERMISSION OF SAFEROADS PTY. LTD. UNLESS OTHERWISE SPECIFIED. ALL DIMENSIONS ARE IN mm. DO NOT SCALE DRAWING. DRAFTING STANDARD IS TO AS 1100. REFER TO 39P000001 FOR TOLERANCES AND SPECIFICATIONS.</small>	
OSTENDO Code	
Drawn	Material
Appvd	Finish Galvanised
	Weight 450.2 kg



THIRD ANGLE PROJECTION 	A3	SCALE: 1:20	SHEET 2 of 3
Title QuadGuard Transition			
Drawing Number SRA000119			Revision A

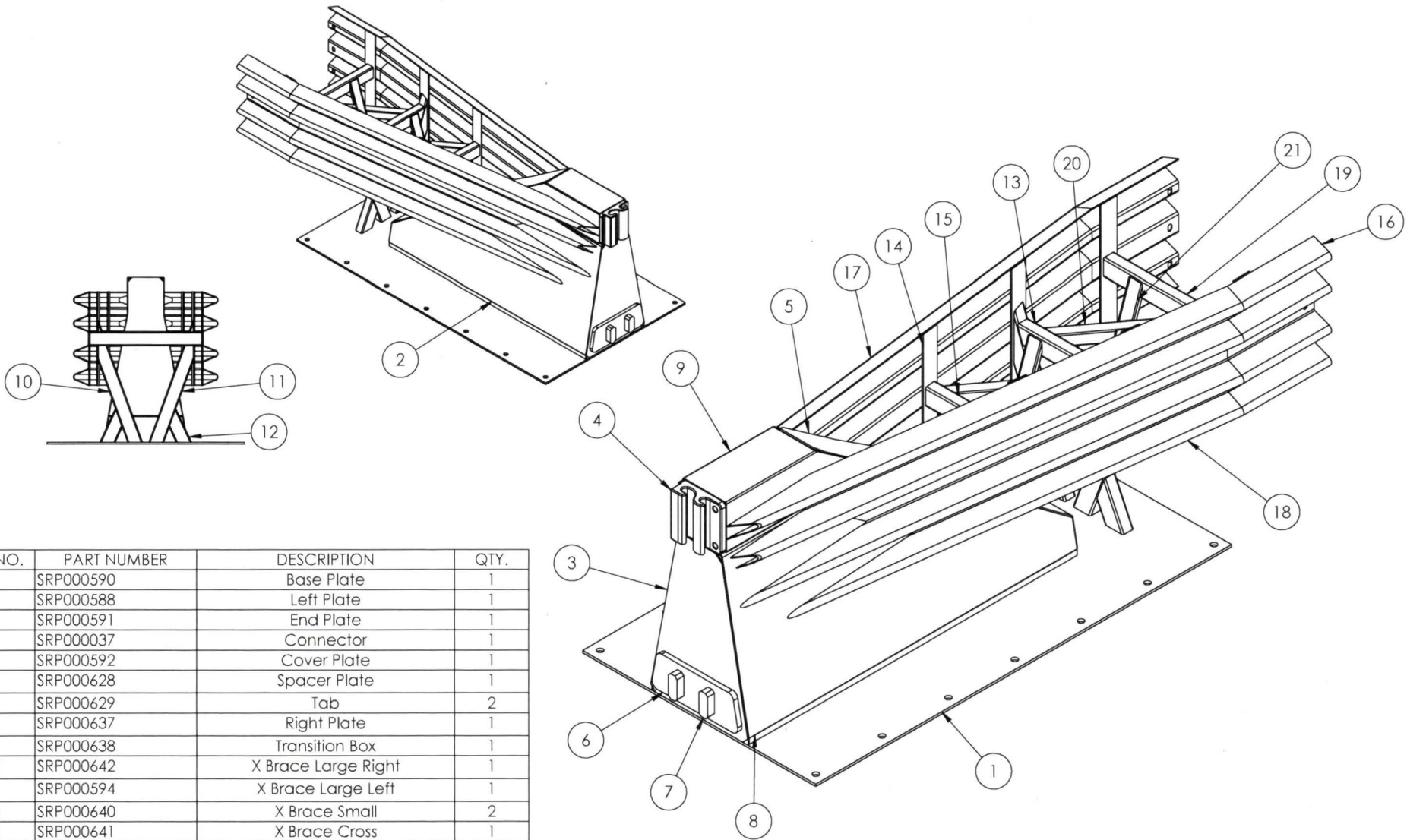

ITEM NO.	PART NUMBER	DESCRIPTION	QTY.
1	SRP000590	Base Plate	1
2	SRP000588	Left Plate	1
3	SRP000591	End Plate	1
4	SRP000037	Connector	1
5	SRP000592	Cover Plate	1
6	SRP000628	Spacer Plate	1
7	SRP000629	Tab	2
8	SRP000637	Right Plate	1
9	SRP000638	Transition Box	1
10	SRP000642	X Brace Large Right	1
11	SRP000594	X Brace Large Left	1
12	SRP000640	X Brace Small	2
13	SRP000641	X Brace Cross	1
14	SRP000595	Crossmember Plate	6
15	SRP000593	Crossmember	1
16	SRP000589	Quad Beam Short	2
17	SRP000643	Quad Beam Long	1
18	SRP000644	Quad Beam Long	1
19	SRP000645	Backup Crossmember	1
20	SRP000646	Horizontal X Brace Long	2
21	SRP000647	Horizontal X Brace Short	4

© THIS DESIGN IS THE PROPERTY OF SAFEROADS. IT MUST NOT BE COPIED OR REPRODUCED WITHOUT THE SPECIFIC WRITTEN PERMISSION OF SAFEROADS PTY. LTD. UNLESS OTHERWISE SPECIFIED. ALL DIMENSIONS ARE IN mm. DO NOT SCALE DRAWING. DRAFTING STANDARD IS TO AS 1100. REFER TO SRP000001 FOR TOLERANCES AND SPECIFICATIONS.

OSTENDO Code

Drawn	Material
App'd	Finish Galvanised
	Weight 450.2 kg

THIRD ANGLE PROJECTION

A3	SCALE: 1:12	SHEET 3 of 3
Title QuadGuard Transition		
Drawing Number SRA000119		Revision A