

LS-44



U.S. Department of Transportation

400 Seventh St., S.W.
Washington, D.C. 20590

Federal Highway Administration

May 28, 1996

Refer to: HNG-14

Dennis H. O'Brien, P.E.
Manager of Product Planning
Industrial Products Division
Valmont Industries, Inc.
Valley, Nebraska 68064-0358

Dear Mr. O'Brien:

This is in response to your April 16 letter to Mr. Gerald L. Eller in which you requested Federal Highway Administration's (FHWA) acceptance of your company's breakaway coupling design for use with luminaire supports. Your letter was accompanied by the Southwest Research Institute report, Pendulum Test Report of a Breakaway Coupling, dated March 1996.

During your visit on April 17, you showed us a video of the crash testing that was conducted to assess the breakaway performance of the prototype couplings. You also showed us examples of the prototype coupling and the coupling as you expect to produce it in the future. As shown in the enclosed drawings of the tested prototype, each of the four couplings supporting the pole is a miniature four-bolt slip base.

Testing was done in accordance with the National Highway Cooperative Research Program Report 350, Recommended Procedures for the Safety Performance Evaluation of Highway Features. Requirements for breakaway supports are those in the American Association of State Highway and Transportation Officials' (AASHTO) Standard Specifications for Structural Supports for Highway Signs, Luminaires and Traffic Signals. Drawings of the test installation and the tested coupling are enclosed.

A summary of the crash test is presented below:

Test Number	VAL-7
Foundation Condition	Rigid test mounting
Luminaire & Support Mass, kg (wt., lbs)	461 (1017)
Bolt Circle Diameter, mm (in)	381 (15)
Pendulum Mass, kg (wt., lbs)	816 (1800)
Impact Speed, km/h (mph)	35.28 (23.4)
Pendulum Velocity Change, m/s (fps)	3.1 (10.1)
Calculated Change @ 100 km/h, m/s (fps)	4.8 (15.9)
Stub Height, mm (in)	32 (1.2)

The results of the test and the high-speed extrapolation meet the change-in-velocity and stub-height requirements adopted by the FHWA. Your company's breakaway coupling for luminaire supports is therefore acceptable for use on projects on the National Highway System (NHS) where breakaway systems are required if proposed by a State.

We note that the weight of the tested pole was 1017 pounds (461 kg). While this is only slightly over the 1000 pounds (453.6 kg) we have suggested limiting luminaire pole weights to in the past, we believe we must comment on this overage. In the future we will be recommending that the mass of breakaway luminaire and similar supports not exceed a recommended maximum mass of 450 kg (992 pounds) with a maximum plus tolerance of 1 percent, which would set the actual maximum mass at 454.5 kg (1002 pounds).

You also requested our acceptance of a proposed "production" coupling, a modified version of the tested prototype. Since this coupling is of different materials, finish, and size from the tested device, any one of which features could cause a change in test results, we cannot find the proposed breakaway coupling acceptable for use unless qualified through testing.

Our acceptance is limited to the breakaway characteristics of the tested coupling as shown in the enclosed drawings and does not cover its structural features. Presumably, you will supply potential users with sufficient information on design and installation requirements to ensure proper performance. We anticipate that the States will require certification from Valmont that the hardware furnished has essentially the same chemistry, mechanical properties, and geometry as that used in the crash testing and that it will meet the FHWA change in velocity requirements.

Should you seek to patent your couplings and are ultimately successful, they will be proprietary products. To be used in Federal-aid projects, except exempt, non-NHS projects, proprietary products: (a) must be supplied through competitive bidding with equally suitable unpatented items; (b) the highway agency must certify that they are essential for synchronization with existing highway facilities or that no equally suitable alternative exists; or (c) they must be used for research or for a distinctive type of construction on relatively short sections of road for experimental purposes. Our regulations concerning proprietary products are contained in Title 23, Code of Federal Regulations, Section 635.411, a copy of which is enclosed.

Sincerely yours,

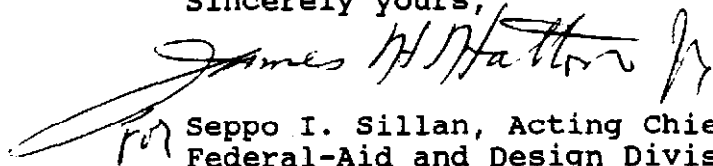

for Seppo I. Sillan, Acting Chief
Federal-Aid and Design Division

Enclosures

Geometric and Safety Design Group Acceptance Letter LS-44

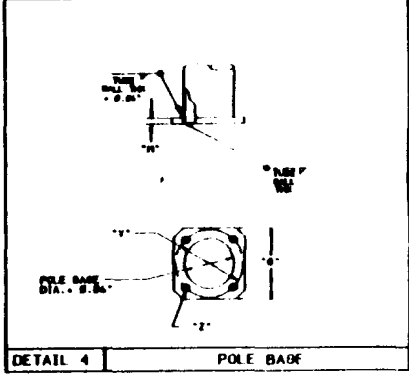
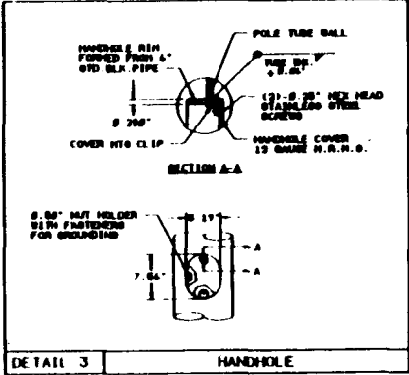
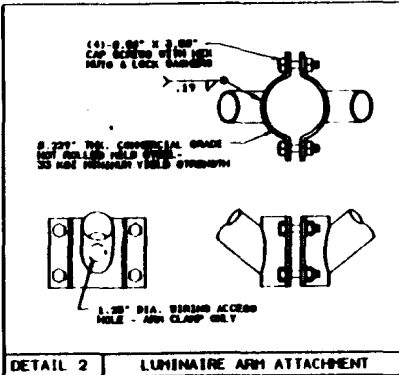
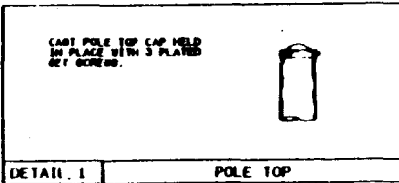
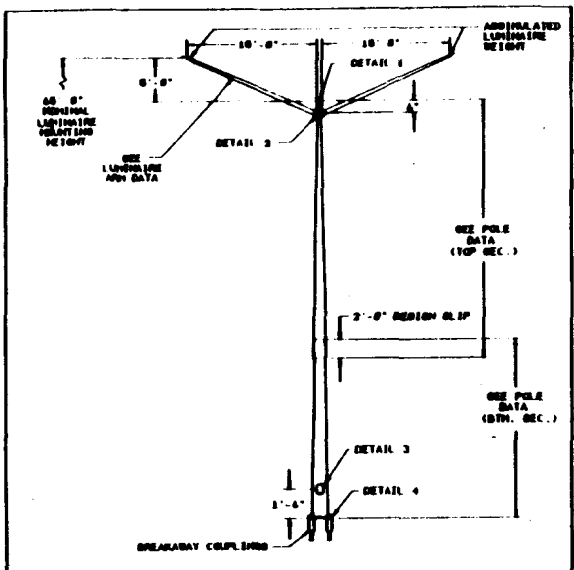

WEIGHT AND FINISH DATA

COMPONENT	QTY.	FINISH
BOTTOM POLE SECTION	1	POWDER COATED
TOP POLE SECTION	1	
LUMINAIRE ARM	2	
ADDITIONAL LUMINAIRE	2	

POLE AND LUMINAIRE ARM DATA

ITEM	QTY.	POLE TUBE - BTH. SEC.				POLE TUBE - TOP SEC.				POLE BASE				ANCHOR BOLT				LUMINAIRE ARM TUBE				
		BASE DIA. (IN)	TOP DIA. (IN)	LENGTH (FT)	WALL THICK. (IN)	BASE DIA. (IN)	TOP DIA. (IN)	LENGTH (FT)	WALL THICK. (IN)	RELEASE (IN)	BOLT CIRCUM. (IN)	THK. (IN)	HOLE/BLT (IN)	DIA. (IN)	LENGTH (IN)	HEAD (IN)	THREAD LENGTH (IN)	FIXED END DIA. (IN)	FREE END DIA. (IN)	WALL THICK. (IN)	SPAN (FT)	RISE (FT)
1		12.00'	9.00'	10'-0"	7	10.00'	3.00'	44'-0"	11	10.00'	10.00'	1.00'	1.25"	N.A.	N.A.	N.A.	N.A.	4.64"	2.48"	11	0.000	0.000

TEST STRUCTURE FOR BREAKAWAY COUPLING

DATE: 6-12-75

ORDER NO.: 42432 75

84763395

VAIRMONT LIGHTING STRUCTURES

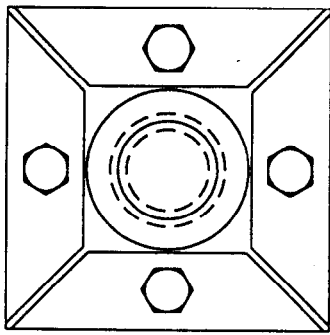

TOP VIEW

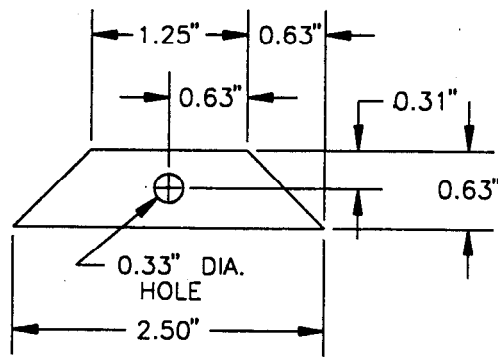

MATERIAL- COLD DRAWN STEEL BAR

SLIP BAR
PLAN VIEW

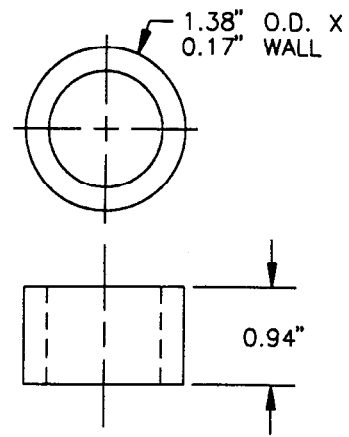

MATERIAL- COLD DRAWN
STEEL TUBING
SPACER

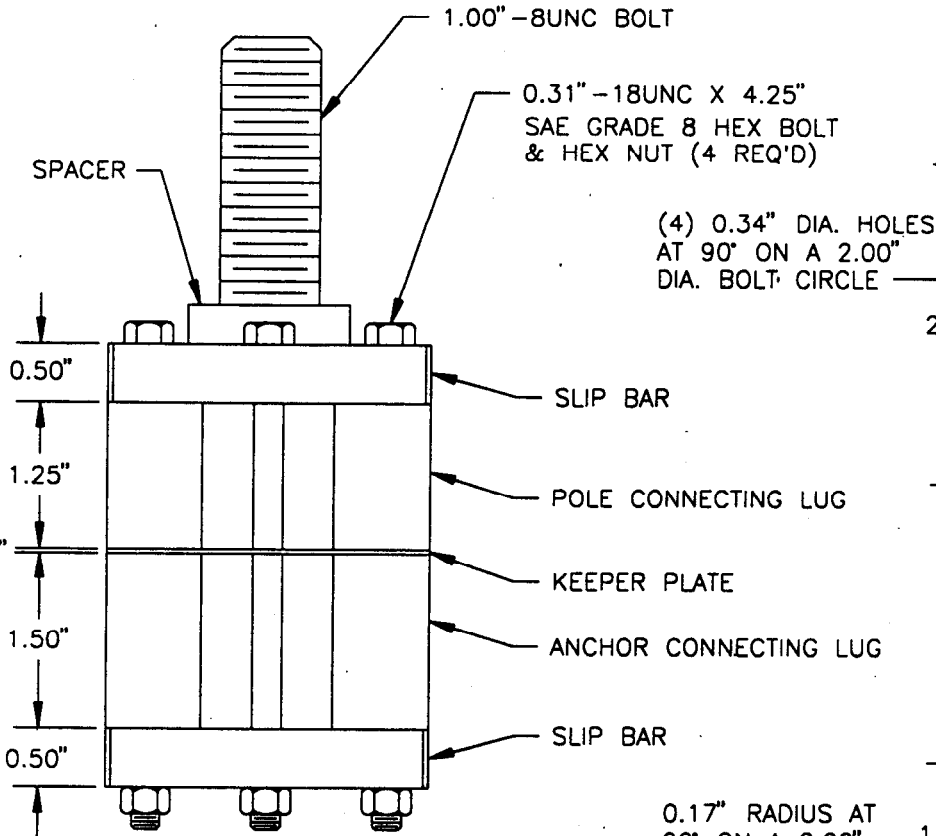

ELEVATION VIEW

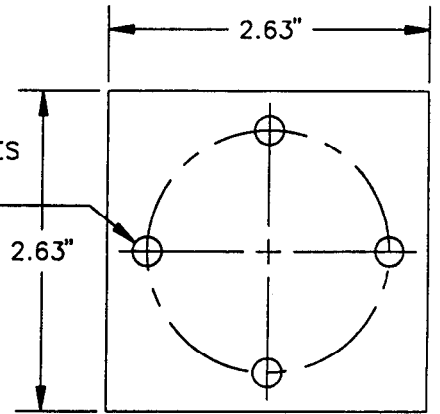

MATERIAL- ZINC SHEET STOCK
KEEPER PLATE
PLAN VIEW

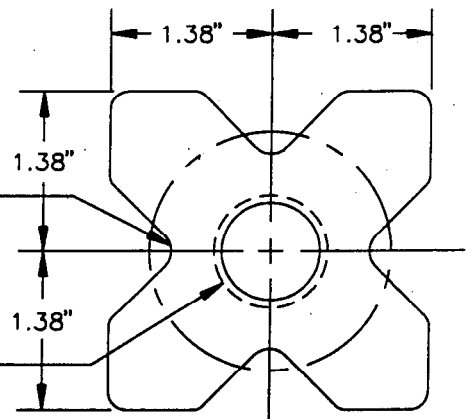

MATERIAL- ASTM: A36 PLATE

POLE & ANCHOR
CONNECTING LUG
PLAN VIEW

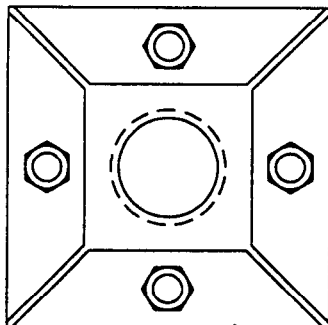

BOTTOM VIEW

FINISH:
ALL PIECE PARTS MECHANICALLY
GALVANIZED TO ASTM: B695
CLASS 55.

HNG-14
LS-44A



U.S. Department
of Transportation

Federal Highway
Administration

February 24, 1997

400 Seventh St., S.W.
Washington, D.C. 20590

Refer to: HNG-14

Armand A. Damiano, P.E.
Product Development Manager
Valmont Industries, Inc.
West Highway 275
P.O. Box 358
Valley, Nebraska 68064-0358

Dear Mr. Damiano:

This is in response to your December 30, 1996, letter to Mr. Gerald L. Eller in which you requested the Federal Highway Administration's (FHWA) acceptance of your company's breakaway coupling design for use with luminaire supports. Your letter was accompanied by the Southwest Research Institute report, Pendulum Test Report of a Breakaway Coupling, Test No. VM-3, dated December 1996. Our letter of May 28, 1996, to Mr. Dennis O'Brien accepted a prototype version of this coupling which was fabricated from ASTM A-36 steel. The recently tested production model was made using powdered metal technology. The powdered metal parts met MPIF Standard 35 Designation Code FC-0208-50. A copy of this specification, which was issued by Metal Powdered Industry Federation, was provided to us on January 23.

Pendulum testing was done in accordance with the National Cooperative Highway Research Program Report 350, Recommended Procedures for the Safety Performance Evaluation of Highway Features. Requirements for breakaway supports are those in the American Association of State Highway and Transportation Officials' (AASHTO) Standard Specifications for Structural Supports for Highway Signs, Luminaires and Traffic Signals. Drawings of the test installation and your company's couplings are enclosed.

A summary of the crash test is presented below:

Test Number	VM-3
Foundation Condition	Rigid test mounting
Luminaire & Support Mass Kg (wt ,lbs)	461 (1017)
Bolt Circle Diameter, mm (in)	381 (15)
Pendulum Mass, kg (wt, lbs)	816 (1800)
Impact Speed, km/h (mph)	35.28 (23.4)
Pendulum Velocity Change, m/s (fps)	3.2 (10.6)
Calc. Vel., Change @ 100 km/h, m/s (fps)	4.9 (16.0)
Stub Height, mm (in)	38 (1.5)

The results of the test and the high-speed extrapolation meet the change-in-velocity and stub-height requirements adopted by the FHWA. Your company's breakaway coupling for luminaire supports as shown in the cited, enclosed drawing is therefore acceptable for use on projects on the National Highway System (NHS) where breakaway systems are required if proposed by a State.

Our acceptance is limited to the breakaway characteristics of the tested coupling as shown in the enclosed drawings and does not cover its structural features. Presumably, you will supply potential users with sufficient information on design and installation requirements to ensure proper performance. We anticipate that the States will require certification from Valmont Industries that the hardware furnished has essentially the same chemistry, mechanical properties, and geometry as those used in the crash testing, and that it will meet the FHWA change in velocity requirements.

We understand that you are seeking to patent this breakaway coupling. If patented, it will be a proprietary product. To be used in Federal-aid projects, except exempt, non-NHS projects, proprietary products: (a) must be supplied through competitive bidding with equally suitable unpatented items; (b) the highway agency must certify that they are essential for synchronization with existing highway facilities or that no equally suitable alternative exists; or (c) they must be used for research or for a distinctive type of construction on relatively short sections of road for experimental purposes. Our regulations concerning proprietary products are contained in Title 23, Code of Federal Regulations, Section 635.411, a copy of which is enclosed.

Sincerely yours,

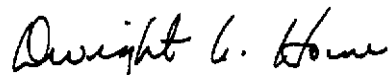

Dwight A. Horne, Chief
Federal-Aid and Design Division

2 Enclosures

Federal Highway Administration
HNG-14:NArtimovich:366-1331:gm:2-10-97:DAMIANO
copies to: HNG-1 HNG-10 HNG-14
Reader, 3128 File 3128
RAs HFL-1 HHS-10 HNG-30 HNG-20 HSR-20

Supplemental Geometric and Safety Design Group Acceptance
Letter LS-44A



U.S. Department
of Transportation
**Federal Highway
Administration**

APR 2 1997

400 Seventh St., S.W.
Washington, D.C. 20590

Refer to: HNG-14

Armand A. Damiano, P.E.
Product Development Manager
Valmont Industries, Inc.
West Highway 275
P.O. Box 358
Valley, Nebraska 68064-0358

Dear Mr. Damiano:

This is in response to your March 3 letter to Mr. Nicholas A. Artimovich, II, in which you requested Federal Highway Administration's acceptance of a change in the fastener hardware used in your company's breakaway coupling design for use with luminaire supports. The coupling with original hardware, shown in the enclosed drawing with the new hardware, was found acceptable in our letter LS-44A dated February 24 and used SAE Grade 8 fasteners. Your request is to substitute ASTM A574 fasteners for the originally accepted fasteners. These substitute fasteners have a 20 percent higher tensile strength than the original. You indicate that this change will increase the load capacity and fatigue strength of the coupling.

Because *of your* manufacturing and quality control procedures, this change in fasteners will have no effect on the clamping force they exert and, thus, no effect on the breakaway performance of the Valmont coupling, we find that such a substitution will be acceptable. All other conditions in our previous letter, referenced above, regarding the use of the coupling remain in-effect.

Sincerely yours,

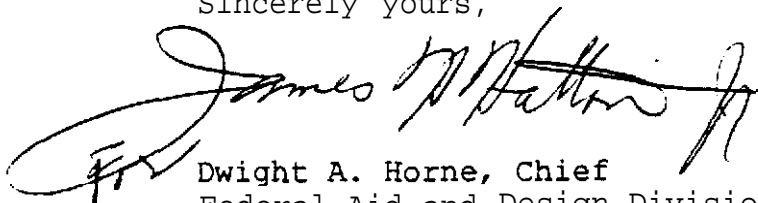

Dwight A. Horne, Chief
Federal-Aid and Design Division

Enclosure

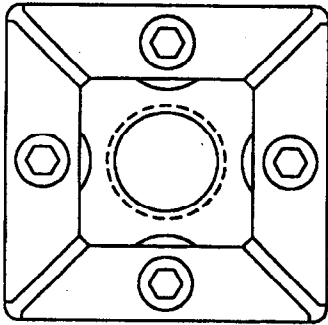
BREAKAWAY COUPLING

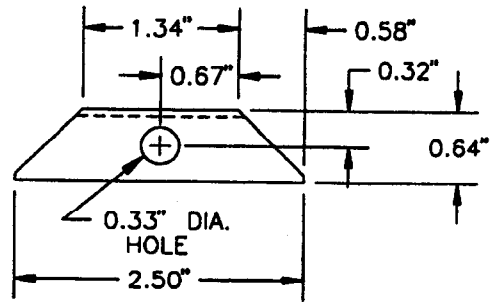

TOP VIEW



MATERIAL - MPIF STANDARD 35
DESIGNATION CODE FC-0208-50

SLIP BAR
PLAN VIEW

(4) 0.34" DIA. HOLES
AT 90° ON A 2.15"
DIA. BOLT CIRCLE

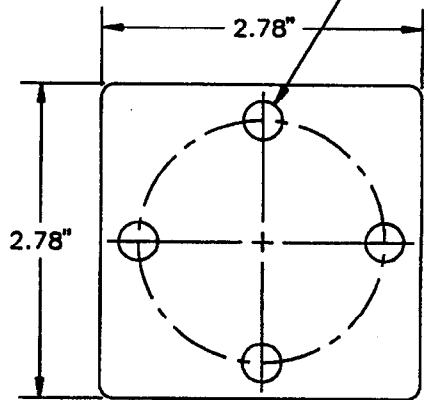

MATERIAL - ZINC ALLOY 750
KEEPER PLATE
PLAN VIEW

0.31" - 18UNC (M8 METRIC)
X 2.75" LONG ASTM A574
ALLEN SOCKET HEAD SCREW
W/HEX NUT (4 REQ'D)

SLIP BAR
CONNECTING LUG
KEEPER PLATE
CONNECTING LUG
SLIP BAR

0.31" REGULAR HELICAL
SPRING LOCK WASHER
0.078" MEAN THICKNESS
ANSI B18.21.1 (4 REQ'D)

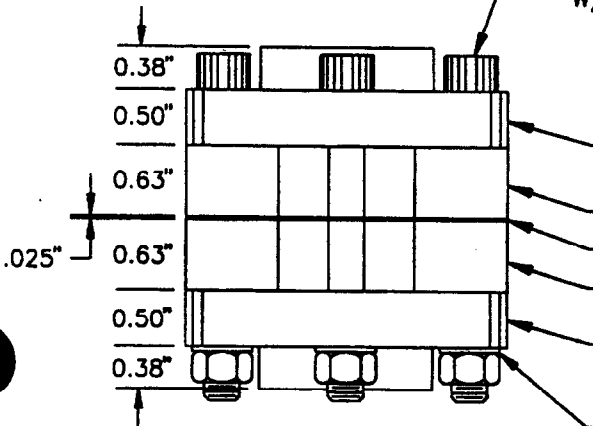

ELEVATION VIEW

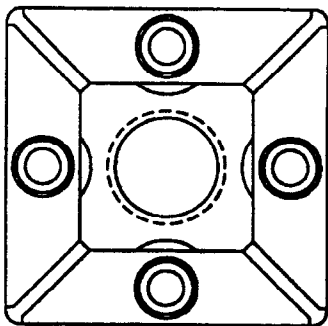

BOTTOM VIEW

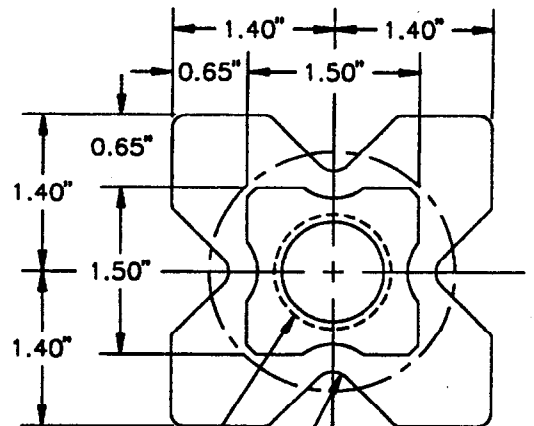

THREADED HOLE
TO 1.00" ENGLISH
OR M27 METRIC

0.17" RADIUS AT
90° ON A 2.15"
DIA. BOLT CIRCLE

MATERIAL - MPIF STANDARD 35
DESIGNATION CODE FC-0208-50

CONNECTING LUG
PLAN VIEW

FINISH:
ALL PIECE PARTS (EXCEPT KEEPER PLATE)
MECHANICALLY GALVANIZED TO ASTM: B695
CLASS 55.