

FHWA Report No. FHWA-RD-99-147

Materials and Procedures for Sealing and Filling Cracks in Asphalt-Surfaced Pavements

Manual of Practice



Federal Highway Administration
U.S. Department of Transportation



Strategic Highway Research Program
National Research Council

FOREWORD

This manual (FHWA-RD-99-147) is an update of the Strategic Highway Research Program (SHRP) manual of practice (SHRP-H-348) on asphalt-surfaced pavement repair. The Federal Highway Administration, Long Term Pavement Performance Program (LTPP) conducted five years of additional research on asphalt-surfaced pavement repair after the conclusion of SHRP. This research validated the repair procedures contained in the original SHRP manual. The manual presents guidelines and recommendations to assist highway maintenance agencies and other related organizations in planning, constructing, and monitoring the performance of asphalt pavement crack treatment (i.e., sealing and filling) projects. Included in the manual are discussions pertaining to when crack treatment operations are appropriate, the types of sealant/filler materials and construction methods that should be used, how each individual step in a crack treatment operation should be performed, and how the performance and cost-effectiveness of crack treatments can be evaluated. This report will be of interest and benefit to various levels of agency maintenance personnel, from crew supervisors to the chief maintenance engineer.

NOTICE

This document is disseminated under the sponsorship of the Department of Transportation in the interest of information exchange. The United States Government assumes no liability for its contents or use thereof. This report does not constitute a standard, specification, or regulation.

The United States Government does not endorse products or manufacturers. Trade and manufacturers' names appear in this report only because they are considered essential to the object of the document.

1. Report No. FHWA-RD-99-147		2. Government Accession No.		3. Recipient's Catalog No.	
4. Title and Subtitle MATERIALS AND PROCEDURES FOR SEALING AND FILLING CRACKS IN ASPHALT-SURFACED PAVEMENTS--MANUAL OF PRACTICE		5. Report Date			
		6. Performing Organization Code			
7. Author(s) K.L. Smith and A.R. Romine		8. Performing Organization Report No.			
9. Performing Organization Name and Address ERES Consultants A Division of Applied Research Associates, Inc. 505 W. University Avenue Champaign, IL 61820-3915		10. Work Unit No. (TRAIS)			
		11. Contract or Grant No. DTFH61-93-C-00051			
12. Sponsoring Agency Name and Address Federal Highway Administration Pavement Performance Division 6300 Georgetown Pike McLean, Virginia 22101		13. Type of Report and Period Covered Updated Manual of Practice October 1993 - June 1999			
		14. Sponsoring Agency Code			
15. Supplementary Notes FHWA Contracting Officer's Technical Representative (COTR): Shahed Rowshan, HRDI Project Consultants: Charlie Smyth					
16. Abstract The Strategic Highway Research Program (SHRP) H-106 maintenance experiment and the Federal Highway Administration (FHWA) <i>Long-Term Monitoring (LTM) of Pavement Maintenance Materials Test Sites</i> project studied the treatment (sealing and filling) of cracks in asphalt-surfaced pavements. Many different treatment materials and methods were investigated between 1991 and 1998 through test sites installed at five locations in the United States and Canada. The findings of these combined studies have been merged with standard highway agency procedures to provide the most useful and up-to-date information on the practice of asphalt crack treatment. This Manual of Practice is an updated version of the 1993 SHRP Crack Sealing and Filling Manual. It contains the latest information pertaining to the performance of treatment materials and methods, the availability and relative costs of sealant/filler materials, and the proper ways of planning, designing, constructing, and monitoring the performance of crack treatment projects. It also provides an updated partial listing of material and equipment manufacturers. This Manual is intended for field and office personnel within highway maintenance agencies and contracted maintenance firms. It contains valuable information for supervisors and foremen in charge of individual crack treatment operations, engineers in charge of planning and overseeing many crack treatment projects, and managers in charge of establishing crack treatment policies and standards.					
17. Key Words Asphalt pavement, pavement maintenance, cracks, crack sealing, crack filling, crack treatment, configuration, performance, effectiveness, cost-effectiveness			18. Distribution Statement No restrictions. This document is available to the public through the National Technical Information Service, Springfield, Virginia 22161.		
19. Security Classif. (of this report) Unclassified		20. Security Classif. (of this page) Unclassified		21. No of Pages 108	22. Price

Preface

This manual is intended for use by highway maintenance agencies and contracted maintenance firms in the field and in the office. It is a compendium of good practices for asphalt concrete (AC) crack sealing and filling operations, stemming from the Strategic Highway Research Program (SHRP) pavement maintenance studies and a follow-up study sponsored by the Federal Highway Administration (FHWA).

In SHRP project H-105, *Innovative Materials and Equipment for Pavement Surface Repair*, the researchers conducted a massive literature review and a nationwide survey of highway agencies to identify potentially cost-effective repair and treatment options (Smith et al., 1991). The information and findings from that study were then used in the subsequent field experiments conducted under SHRP project H-106, *Innovative Materials Development and Testing*.

In project H-106, many different test sections were installed and evaluated to determine the cost-effectiveness of maintenance materials and procedures. Test sections were installed at 22 sites throughout the United States and Canada between March 1991 and February 1992, under the supervision of SHRP representatives. The researchers collected installation and productivity information at each site and periodically evaluated the experimental repairs and treatments through the end of 1992. The first version of this manual was prepared in October 1993 and was based on this work effort.

Following the conclusion of SHRP H-106 in 1993, the FHWA sponsored a study to continue monitoring the performance of the experimental repairs and treatments, beginning in October 1993. Under the *Long-Term Monitoring (LTM) of Pavement Maintenance Materials Test Sites* project, the repairs and treatments were evaluated annually through the end of 1997.

Pertinent long-term performance and cost-effectiveness information generated by the continued monitoring of the experimental crack treatments has been included in this revised manual.

For the reader's convenience, potentially unfamiliar terms are italicized at their first occurrence in the manual and are defined in a glossary. Readers who want more information on topics included in this manual should refer to the reference list provided at the back. The final report for the H-106/*LTM* AC crack treatment study may be of particular interest to many readers (Smith and Romine, 1999). It details the installation procedures, laboratory testing of the materials, and long-term field performance and cost-effectiveness of each crack treatment type investigated.

Acknowledgments

The research described herein was supported by the Strategic Highway Research Program and the Federal Highway Administration. SHRP was a unit of the National Research Council that was authorized by section 128 of the Surface Transportation and Uniform Relocation Assistance Act of 1987.

Special thanks are due to the project management teams at SHRP and the FHWA, and to the following State/Provincial highway agencies:

- ! Texas State Department of Highways and Public Transportation.
- ! Kansas Department of Transportation.
- ! Washington State Department of Transportation.
- ! Iowa Department of Transportation.
- ! Ministry of Transportation of Ontario.

The contributions of the following individuals are also acknowledged: Michael Darter, Sam Carpenter, David Peshkin, Mike Belangie, Henry Bankie, Jim Chehovits, and Charlie Smyth.

Contents

1.0	Introduction	1
1.1	Scope of Manual	2
2.0	Need for Crack Treatment	5
2.1	Pavement/Crack Evaluation	5
2.2	Determining the Type of Maintenance	7
2.2.1	Other Considerations	10
2.3	Objectives of Sealing and Filling	10
2.4	Determining Whether to Seal or Fill	11
2.4.1	When to Seal and When to Fill	12
3.0	Planning and Design	15
3.1	Primary Considerations	15
3.2	Selecting a Sealant or Filler Material	16
3.2.1	Laboratory Testing	22
3.3	Selecting a Placement Configuration	23
3.4	Selecting Procedures and Equipment	29
3.4.1	Crack Cutting	31
3.4.2	Crack Cleaning and Drying	36
3.4.3	Material Preparation and Application	40
3.4.4	Material Finishing/Shaping	44
3.4.5	Material Blotting	45
3.5	Estimating Material Requirements	46
3.6	Cost-Effectiveness Analysis	46
4.0	Construction	49
4.1	Traffic Control	49
4.2	Safety	50
4.3	Crack Cutting	50
4.4	Crack Cleaning and Drying	51
4.4.1	High-Pressure Airblasting	53
4.4.2	Hot Airblasting	53
4.4.3	Sandblasting	55
4.4.4	Wirebrushing	55

4.5	Material Preparation and Application	56
4.5.1	Installing Backer Rod	57
4.5.2	Material Preparation	58
4.5.3	Material Application	60
4.5.4	Asphalt Kettle Cleanout	62
4.6	Material Finishing/Shaping	63
4.7	Material Blotting	64
5.0	Evaluating Crack Treatment Performance	65
Appendix A	Material Testing Specifications	67
Appendix B	Determining Material Quantity Requirements	71
Appendix C	Sample Cost-Effectiveness Calculations	73
Appendix D	Inspection Checklists for Construction	77
D.1	Crack Cutting	77
D.2	Crack Cleaning and Drying	78
D.3	Material Preparation and Installation	79
D.3.1	Backer Rod Installation	79
D.3.2	Sealant or Filler Preparation and Installation	80
D.4	Material Finishing/Shaping	81
D.5	Material Blotting	82
Appendix E	Material and Equipment Safety Precautions	83
E.1	Materials	83
E.2	Equipment	83

Appendix F	Partial List of Material and Equipment Sources	85
F.1.	Materials	83
F.1.1.	Manufacturers of Cold-Applied Thermoplastic Bituminous Materials	85
F.1.2.	Manufacturers of Hot-Applied Thermoplastic Bituminous Materials	86
F.1.3.	Manufacturers of Self-Leveling Silicone	86
F.2.	Equipment	87
F.2.1.	Manufacturers of Cutting Equipment	87
F.2.2.	Manufacturers of Heat Lances	87
F.2.3.	Manufacturers of Asphalt Kettles . .	87
F.2.4.	Manufacturers of Silicone Pumps . .	88
Glossary	89
References	93

List of Figures

Figure 1.	Asphalt pavement/crack survey form	6
Figure 2.	Pavement candidate for surface treatment: high-density cracking	8
Figure 3.	Pavement candidate for crack repair	8
Figure 4.	Pavement candidate for transverse crack sealing	9
Figure 5.	Pavement candidate for longitudinal crack filling	9
Figure 6.	Material placement configurations	24
Figure 7.	Rotary-impact router	35
Figure 8.	Diamond-blade crack saw	35
Figure 9.	High-pressure airblasting using compressed air	38
Figure 10.	Hot airblasting using HCA (heat) lance	38
Figure 11.	Sandblasting operation	39
Figure 12.	Backer rod installation tool	41
Figure 13.	Asphalt kettle with pressure applicator	42

Figure 14.	Industrial squeegee molded into a "U" shape	45
Figure 15.	Worksheet for determining material quantity requirements	47
Figure 16.	Cost-effectiveness computation worksheet	48
Figure 17.	Crack segment missed by cutting equipment	51
Figure 18.	Primary crack accompanied by secondary crack	52
Figure 19.	Sandblasting wand with wooden guide attached	56
Figure 20.	Example graph of treatment effectiveness versus time	66
Figure B-1.	Solution to material requirements problem	72
Figure C-1.	Example cost-effectiveness analysis	75

List of Tables

Table 1.	Steps in a crack treatment program	3
Table 2.	Guidelines for determining the type of maintenance to be performed	7
Table 3.	Recommended criteria for determining whether to seal or fill	13
Table 4.	Summary of AC crack treatment materials	19
Table 5.	Properties associated with various material types	20
Table 6.	Placement configuration considerations	30
Table 7.	Crack treatment equipment characteristics and recommendations	32
Table 8.	Typical manpower requirements and production rates for crack treatment operations	34
Table A-1.	Asphalt rubber specifications	68
Table A-2.	Self-leveling silicone specifications	68
Table A-3.	Rubberized asphalt specifications	69

1.0 Introduction

Cracking in asphalt concrete (AC)-surfaced pavements is a phenomenon that pavement design and maintenance engineers have had to contend with for years. It is one of two principal considerations (fatigue cracking and rutting) in the pavement design process, and it is often the primary mode of deterioration in AC pavements. Cracks are inevitable, and neglect leads to accelerated cracking and potholing, further reducing pavement *serviceability*.*

The problem of cracks is handled in many ways, ranging from pavement maintenance activities, such as surface treatments and crack filling, to full-scale pavement rehabilitation projects, such as resurfacing. Maintenance departments bear most of the burden of dealing with cracks. Departments with sufficient funding are often responsible for adding a few more years of serviceable life to deteriorated pavements through preventive or routine maintenance, or both.

Two of the more common options exercised by maintenance departments are crack sealing and crack filling. These operations have been conducted for many years, generally on a routine basis. However, only in the last two decades has their potential benefits as preventive maintenance tools been realized. With proper and timely application, crack sealing and filling can extend pavement life past the point where the cost-benefit of added pavement life exceeds the cost of conducting the operation.

* Italicized words are defined in the glossary.

1.1 Scope of Manual

This manual has been prepared to guide pavement maintenance personnel (i.e., engineers, supervisors, and crewpersons) in the selection, installation, and evaluation of materials and procedures used to treat (seal or fill) cracks in AC-surfaced pavements. The information contained herein is based on the most recent research, obtained through literature reviews and current practices, and on the results of a large-scale, long-term crack treatment field study sponsored by the Strategic Highway Research Program (SHRP) and the Federal Highway Administration (FHWA) (Smith et al., 1991; Evans et al., 1993; Smith and Romine, 1999).

This manual provides both general and specific information for carrying out each of four primary phases associated with a *crack treatment* program. These phases are as follows:

1. Determining the need for crack treatment.
2. Planning and designing the crack treatment project.
3. Construction.
4. Evaluating and assessing the performance of the crack treatment.

Crack treatment is far from being the long, involved process typical of a pavement construction or rehabilitation project. However, like these projects, it must be carefully planned and conducted to be successful. Table 1 illustrates the steps involved in the crack treatment process, as well as the factors that must be considered.

Table 1. Steps in a crack treatment program.

Step	Description
1	Obtain and review construction and maintenance records. - Pavement age, design, repairs, and so on.
2	Perform pavement/crack survey. - Record distress types, amounts, and severities.
3	Determine appropriate type of maintenance for cracked pavement based on density and condition of cracks. - High density of cracks having moderate to no edge deterioration Y pavement surface treatment. - Moderate density of cracks having moderate to no edge deterioration Y crack treatment. - Moderate density of cracks having high level of edge deterioration Y crack repair.
4	For crack treatment, determine whether cracks should be sealed or filled. ^a - Cracks typically showing significant annual horizontal movement Y crack sealing. - Cracks typically showing very little annual horizontal movement Y crack filling.
5	Select materials and procedures for crack treatment operation based on the following considerations: - Climate (dry-freeze, dry-nonfreeze, wet-freeze, wet-nonfreeze). - Traffic (high, medium, low). - Crack characteristics (width, deterioration). - Available equipment. - Available manpower. - Cost-effectiveness (anticipated treatment cost and performance).
6	Acquire materials and equipment.
7	Conduct and inspect crack treatment operation.
8	Periodically evaluate treatment performance.

^a See sections 2.3 and 2.4.

2.0 Need for Crack Treatment

If a particular cracked pavement appears to be in need of some sort of maintenance, a relatively quick assessment can be made to ascertain the need and, more importantly, to help in determining the appropriate action. Such an assessment requires an evaluation of existing pavement conditions and a knowledge of future rehabilitation plans, both of which may be found in a pavement management system (PMS).

2.1 Pavement/Crack Evaluation

Although maintenance engineers or supervisors are normally quite familiar with the roads they maintain, a quick review of construction, maintenance, and other records will provide important general information regarding the following:

- ! Pavement age.
- ! Pavement and geometric design.
- ! Pavement section boundaries.
- ! Traffic.
- ! Climate.
- ! Type and extent of previous maintenance treatments.
- ! Condition rating.

After these records are reviewed, a shoulder survey should then be performed on a small representative sample of the pavement section, about 150 m, to determine the amount, type, and condition or severity of cracks, as well as the condition or *effectiveness* of any previously applied crack treatments (see section 5.0). A sample survey form for recording pavement and crack information is provided in figure 1.

Asphalt Pavement/Crack Survey Form

Location and Geometrics

Highway/Road: Milepost/Station of Section:
Number of Lanes: Length of Section:
Lane Widths: Shoulder Type and Width:

Design, Construction, and Rehabilitation

Pavement Type (full-depth AC, conventional AC, composite AC/PCC):
Year of Original Construction:
Type and Year of Most Recent Rehabilitation:
Future Rehabilitation Planned:

Climate, Traffic, and Highway Classification

Average Annual Precipitation (mm):	Pavement Cross-Section	
No. Days Below 0°C:	Material 1 (top) =	Thickness =
No. Days Above 38°C:	Material 2 =	Thickness =
Functional Classification:	Material 3 =	Thickness =
Most Recent 2-Way ADT:	Material 4 (bottom) =	Thickness =

Pavement Condition

Cracking Distress

Primary Crack Type/Orientation:
Density (lin m/150-m section): Average Width (mm):
Edge Deterioration (%):
Cupping? Lipping? Faulting? Average Depth/Height (mm):
Previous Treatment? Y N
Material Type?
Effectiveness (% crack length not failed):

Other Crack Type/Orientation:
Density (lin m/150-m section): Average Width (mm):
Edge Deterioration (%):
Cupping? Lipping? Faulting? Average Depth/Height (mm):
Previous Treatment? Y N
Material Type?
Effectiveness (% crack length not failed):

Other Significant Distresses

Type: Density:
Type: Density:
Type: Density:

Figure 1. Asphalt pavement/crack survey form.

2.2 Determining the Type of Maintenance

The appropriate type of maintenance for cracked pavements often depends on the density and general condition of the cracks. If cracks are abundant and do not exhibit a high degree of *edge deterioration*, they may best be treated through chip seals, slurry seals, or the like. If cracks are low to moderate in density and have typically progressed to a point of high edge deterioration, then *crack repair* strategies, such as partial-depth patching or spot patching, may be warranted. If cracks are moderate in density and show moderate to no deterioration at the edges, then they may be treated effectively through sealing or filling operations. Table 2 summarizes these guidelines.

As table 2 indicates, crack density levels are described in general terms. This is because experienced personnel can make reasonable assessments of density. Figures 2 through 5 illustrate typical crack situations and potential remedies.

Table 2. Guidelines for determining the type of maintenance to be performed.

Crack Density	Average Level of Edge Deterioration (percentage of crack length)		
	Low (0 to 25)	Moderate (26 to 50)	High (51 to 100)
Low	Nothing	Nothing or Crack Treatment	Crack Repair
Moderate	Crack Treatment	Crack Treatment	Crack Repair
High	Surface Treatment	Surface Treatment	Rehabilitation



Figure 2. Pavement candidate for surface treatment:
high-density cracking.



Figure 3. Pavement candidate for
crack repair.



Figure 4. Pavement candidate for transverse crack sealing.



Figure 5. Pavement candidate for longitudinal crack filling.

In general, a large number of cracks or severely deteriorated cracks indicate a pavement in an advanced state of decay. Crack sealing or filling in these circumstances is both uneconomical and technically unsound, as it does little to delay the need for more extensive corrective actions.

Most highway agencies have established policies that specify the type of maintenance to be performed on cracked pavements and when to perform it. The policies are often based on an assessment of the overall pavement condition (extent of cracking) or specific crack characteristics (type and width).

2.2.1 Other Considerations

On occasion, cracks may have other types of deficiencies. In particular, crack edges may exhibit vertical distresses, such as *cupping*, *lipping*, or *faulting*, or may undergo significant vertical deflections or movements under traffic loading. Such deficiencies can add significantly to overall pavement roughness and can deteriorate rapidly.

Normally, repair alternatives such as patching or milling are appropriate for correcting these deficiencies. However, if the amount of vertical deflection and the severity of the distress are not too high, a temporary fix with crack treatment may be adequate.

2.3 Objectives of Sealing and Filling

Although little distinction has been made in the past between crack sealing and crack filling, the purposes and functions of each must be clearly understood so that the most cost-effective and long-lasting treatment is applied.

Crack Sealing—The placement of specialized treatment materials above or into *working* cracks using unique configurations to prevent the intrusion of water and *incompressibles* into the crack.

Crack Filling—The placement of ordinary treatment materials into *non-working* cracks to substantially reduce infiltration of water and to reinforce the adjacent pavement.

As these definitions indicate, the objectives of crack sealing are significantly more difficult to accomplish than those of crack filling. Sealing requires considerably more forethought, greater costs, and the use of more specially formulated materials and more sophisticated equipment.

It is assumed in this manual that where cracks are exhibiting significant vertical deflections, the appropriate repair strategy will be sought. Hence, for cracks with limited vertical movement, horizontal movement becomes the critical factor in determining the need for, and planning of, a crack treatment operation.

2.4 Determining Whether to Seal or Fill

Frequently, the first cracks to appear in a pavement are *transverse* cracks. However, several different types of cracks may appear at one time. In these cases, one treatment, using a material appropriate for the most demanding crack type, is desirable.

Though crack width may be a factor in determining whether to seal or fill, the amount of annual horizontal movement of the targeted crack type should be the principal basis for this decision. Normally, working cracks with limited edge deterioration should be sealed, whereas non-working cracks with moderate to no edge deterioration should be filled.

Whether a crack is working or non-working can generally be determined by its type. Working cracks are usually transverse in orientation; however, some *longitudinal* and diagonal cracks may meet the 3-mm movement criteria. Materials placed in working cracks must adhere to the crack sidewalls and flex as the crack opens and closes. Rubber-modified materials designed for low-stress elongation, especially at low temperatures, are preferred for treating these cracks.

Non-working cracks typically include diagonal cracks, most longitudinal cracks, and some block cracks. Because of the relatively close spacing or free edges between non-working cracks, little movement occurs. Minimal movement permits the use of less expensive, less specialized crack-filler materials. Experienced personnel can usually determine if the targeted crack type is working or non-working, and table 3 provides recommended criteria for determining which cracks to seal and which to fill.

2.4.1 When to Seal and When to Fill

Crack sealing is a preventive maintenance activity. Ideally, it is conducted shortly after working cracks have developed to an adequate extent and at a time of year when temperatures are moderately cool (7 to 18°C), such as in the spring or fall. When newly developed cracks are sealed, deteriorated crack segments (i.e., *secondary cracks, spalls*), which adversely affect seal performance, are minimized. Typically, transverse

Table 3. Recommended criteria for determining whether to seal or fill.

Crack Characteristics	Crack Treatment Activity	
	Crack Sealing	Crack Filling
Width, mm	5 to 19	5 to 25
Edge Deterioration (i.e., spalls, secondary cracks)	Minimal to None (≤ 25 percent of crack length)	Moderate to None (≤ 50 percent of crack length)
Annual Horizontal Movement, mm	≥ 3	< 3
Type of Crack	Transverse Thermal Cracks Transverse Reflective Cracks Longitudinal Reflective Cracks Longitudinal Cold-Joint Cracks	Longitudinal Reflective Cracks Longitudinal Cold-Joint Cracks Longitudinal Edge Cracks Distantly Spaced Block Cracks

thermal cracks in AC flexible pavements appear 2 to 7 years after construction, whereas transverse reflection cracks in AC-overlaid concrete pavements often materialize 1 to 3 years after resurfacing.

Sealing in moderately cool temperatures is beneficial from two standpoints. First, cracks are partly opened so that a sufficient amount of material can be placed in the crack if cutting is not to be performed. Second, the width of the *crack channel*, whether cut or uncut, is nearly at the middle of its working range. This is important to the performance of the sealant material because it will not have to undergo excessive extension or contraction.

Most crack filling operations can be conducted year-round; however, they often take place during cool or moderately cool weather (2 to 13°C). At these temperatures, cracks are mostly or completely open, and more material can be applied.

Crack filling operations can be preventive or routine in nature, depending on the highway agency's approach to treating the cracks. Like sealing operations, preventive crack filling maintenance should be conducted shortly after non-working cracks have developed adequately. Depending on the type of cracks to be filled, this may occur as early as between 4 and 8 years after construction or resurfacing. Durable filler materials should be used to reduce the number of repeat applications. By filling cracks shortly after they are fully developed, further growth is delayed.

Historically, most crack filling has been performed on a routine basis with inappropriate materials that provide less than desirable performance. This approach to crack filling is rarely cost-effective because treatment performance is generally poor and maintenance costs are high. In addition, the safety of the workers and traveling public is compromised, since the filling operation must be repeated frequently.

3.0 Planning and Design

3.1 Primary Considerations

The following factors should be addressed when planning crack sealing or crack filling operations:

1. Climatic conditions.
 - a. At time of installation.
 - b. In general.
2. Highway classification.
3. Traffic level and percent trucks.
4. Crack characteristics and density.
5. Materials.
6. Material placement configurations.
7. Procedures and equipment.
8. Safety.

The planning process centers on selecting an appropriate material and placement configuration, and determining the procedures and equipment to be used based on existing and future roadway conditions.

The site-specific climatic conditions during treatment operations can occasionally influence which procedures or materials should be used. For instance, in areas where moisture or cold temperatures present scheduling problems, the use of a heat lance may expedite operations.

Overall climatic conditions must also be considered in deciding which materials and procedures are to be used. Hot climates necessitate the use of materials that will not significantly soften and track at high temperatures. Very cold climates, on the other hand, will generally require materials that retain good flexibility at low temperatures.

Highway classification and traffic characteristics are important from two standpoints. First, highway geometrics and traffic levels may be such that overall safety during installation is greatly compromised. Applying longer lasting treatments reduces the number of subsequent applications. Fewer applications means less time on the roadway and increases safety.

Second, if a material is to be placed in an *overband* configuration, consideration must be given to the amount of traffic expected over the material and whether or not snowplows, particularly direct-contact plows, are used. The most durable, yet flexible, material would be desirable on roads where traffic levels are medium or high (average daily traffic [ADT] > 5,000 vehicles/day) or snowplows are operated.

Crack characteristics, such as width, movement, and edge deterioration, will also influence which materials and procedures should be used. Some of these characteristics, along with crack density, are needed for estimating the amount of material required for the project.

3.2 Selecting a Sealant or Filler Material

There are many crack treatment material products on the market today, each with distinct characteristics. The products essentially comprise three material families and are often grouped by material type, according to their composition and manufacturing process. The principal material families and types are as follows:

- ! Cold-applied *thermoplastic* bituminous materials.
- ŷ Liquid asphalt (emulsion).
- ŷ Polymer-modified liquid asphalt.

- ! Hot-applied thermoplastic bituminous materials.
 - ŷ Asphalt cement.
 - ŷ Fiberized asphalt.
 - ŷ Asphalt rubber.
 - ŷ Rubberized asphalt.
 - ŷ Low-modulus rubberized asphalt.
- ! Chemically cured *thermosetting* materials.
 - ŷ Self-leveling silicone.

Three materials excluded from the list above are asphalt cutbacks, mineral-filled (stone, lime, flyash dust) asphalts, and sand–asphalt mixes. Cutbacks are rarely used today because of environmental hazards, whereas mineral-filled asphalts have generally been found not cost-effective. Sand–asphalt mixes are considered to be crack repair materials.

Among the thermoplastic bituminous materials, asphalt cement and liquid asphalt possess little, if any, flexibility and are very temperature-susceptible. Hence, they are limited to use as fillers for non-working cracks. Similarly, since fiber particles provide minimal elasticity to asphalt and do not significantly affect temperature susceptibility, fiberized asphalts are most appropriate in crack filling operations.

The addition of rubber polymer to liquid or heated asphalt generally improves field performance because it imparts flexibility to the asphalt. The degree of flexibility basically depends on the type and nature of the asphalt, the percentage of vulcanized rubber used, and how the rubber is incorporated into the asphalt (i.e., mixed or melted in). Other polymers are often incorporated into asphalt, either exclusively or along with rubber, to increase resilience. The following is the generally increasing trend in performance characteristics of polymer-modified asphalts:

Polymer-Modified Liquid Asphalt 6 Asphalt Rubber 6
Rubberized Asphalt 6 Low-Modulus Rubberized Asphalt

Chemically cured thermosetting materials are one- or two-component materials that cure by chemical reaction from a liquid state to a solid state. This type of material has been used in AC pavements only in recent years. Self-leveling silicone is a one-component, cold-applied sealant that requires no tooling.

Table 4 provides general information about each material type, including applicable specifications, recommended applications, and typical cost ranges. Generally speaking, the complexity and quality of the materials increase as one scans down the table. Consequently, the costs also increase and the recommended application changes from crack filling to crack sealing.

The first step in selecting a material is to identify the key properties that a material must possess to be efficiently placed and to perform successfully under the conditions provided for the time desired. Several of the more desirable properties include the following:

- ! Short preparation time.
- ! Quick and easy to place (good workability).
- ! Short cure time.
- ! *Adhesiveness*.
- ! *Cohesiveness*.
- ! Resistance to softening and flow.
- ! *Flexibility*.
- ! *Elasticity*.
- ! Resistance to aging and weathering.
- ! *Abrasion* resistance.

Table 5 illustrates the material types that possess most of the above properties. As can be seen, the rubberlike properties associated with some materials make them good choices for

Table 4. Summary of AC crack treatment materials.

Material Type	Applicable Specifications	Recommended Application	Cost Range, \$/kg ^a
Asphalt Emulsion	ASTM ^b D 977, AASHTO ^c M 140, ASTM D 2397, AASHTO M 208	Filling	0.15 to 0.30
Asphalt Cement	ASTM D 3381, AASHTO M 20, AASHTO M 226	Filling	0.15 to 0.30
Fiberized Asphalt	Manufacturer's recommended specs	Filling	0.35 to 0.60
Polymer-Modified Emulsion	ASTM D 977, AASHTO M 140, ASTM D 2397, AASHTO M 208	Filling (possibly sealing)	0.80 to 1.20
Asphalt Rubber	State specs, ASTM D 5078	Sealing (possibly filling)	0.45 to 0.65
Rubberized Asphalt	ASTM D 1190, AASHTO M 173, Fed SS-S-164	Sealing	0.55 to 0.85
	ASTM D 3405, AASHTO M 301, Fed SS-S-1401	Sealing	0.65 to 1.10
Low-Modulus Rubberized Asphalt	State-modified ASTM D 3405 specs	Sealing	0.75 to 1.40
Self-Leveling Silicone	ASTM D 5893	Sealing	5.75 to 6.75

^a Based on 1998 costs.

^b ASTM = American Society for Testing and Materials.

^c AASHTO = American Association of State Highway and Transportation Officials.

Table 5. Properties associated with various material types.

Property	Material Type							
	Emulsion	Asphalt Cement	Fiberized Asphalt	Polymer- Modified Emulsion	Asphalt Rubber	Rubberized Asphalt	Low-Modulus Rubberized Asphalt	Self-Leveling Silicone
Short Preparation	T			T				TT
Quick & Easy to Place	T	TT	TT	T	TT	TT	TT	
Short Cure Time		TT	TT		TT	TT	TT	T
Adhesiveness	TT	TT	T	T	T	T	T	T
Cohesiveness					T	T	TT	T
Resistance to Softening & Flow (cured state)				T	T	T	TT	TT
Flexibility				T	T	T	TT	TT
Elasticity				T	T	T	T	TT
Resistance to Aging & Weathering						T	T	TT
Resistance to Abrasion					T	TT	T	

T Applicable
 TT Very Applicable

sealing working cracks, whereas the preparation and installation attributes of emulsion and asphalt cement make them desirable for crack filling.

Table 5 shows which material types will best meet the demands of the project. For instance, if the material to be used must be moderately flexible, resistant to tracking and abrasion, and rapidly installable, then a rubberized asphalt should be considered. If the project requires a material that is adhesive, resistant to abrasion, rapidly installable, and quick to cure, then asphalt rubber or rubberized asphalt should be considered.

Actual field performance should always be considered when determining which material to use. Maintenance planners should not only keep abreast of the results of national and State crack treatment studies, they should also stay informed of local experiences with material performance. Results from the recently concluded SHRP H-106 crack treatment study indicate the following material performance capabilities, given proper installation (Smith and Romine, 1999):

- ! Emulsion and asphalt cement filler materials placed flush in unrouted, non-working cracks can perform satisfactorily for between 2 and 4 years, whereas rubber- and fiber-modified asphalt fillers placed flush or overbanded in the same cracks can serve effectively for 6 to 8 years.
- ! Rubberized asphalt sealants placed flush or overbanded in routed, working cracks can provide between 5 and 9 years of service, whereas placed overbanded in non-routed working cracks, they can provide 2.5 to 5 years of service.

- ! Self-leveling silicone placed recessed in routed/sawn working cracks can perform satisfactorily for at least 4 to 6 years.

- ! Fiberized asphalt placed overbanded in unrouted, working cracks can provide a maximum of 2 years of adequate service.

To obtain the maximum benefit from each maintenance dollar spent, all costs associated with installing a material must be added and compared with the service life of the material. This is referred to as a cost-effectiveness analysis.

The process of cost-effectiveness analysis is discussed in detail in section 3.6. Results from the SHRP H-106 crack treatment study indicate that the most cost-effective crack fillers are rubber-modified asphalts placed flush or overbanded and fiber-modified asphalts placed overbanded (Smith and Romine, 1999). Results also showed that the most cost-effective, long-term (5 to 8 years) crack sealants are modified rubberized asphalts placed overbanded in routed cracks (Smith and Romine, 1999).

3.2.1 Laboratory Testing

Laboratory testing of the selected sealant or filler material is highly recommended. Testing ensures that the material obtained exhibits the properties for which it was selected.

The testing process begins with material sampling. As a general rule, a minimum sample of 2 to 4 kg should be taken from each batch, or lot, of material shipped. These samples should then be submitted for testing at an agency-approved testing laboratory prior to placement.

Laboratory testing should be conducted in full accordance with the test methods specified for the material. Variations in testing parameters, such as rates, temperatures, and specimen sizes, can significantly affect test results.

If the material does not meet all applicable specifications, it should be rejected. On the other hand, good performance does not guarantee material compliance with specifications. **Proper installation is a must, no matter how good the material!**

For commonly used test criteria for the major sealant material types, refer to appendix A.

3.3 Selecting a Placement Configuration

Sealant and filler materials can be placed in cracks in numerous configurations; the most common are shown in figure 6. These placement configurations are grouped into four categories (Cook et al., 1991):

- ! Flush fill.
- ! Reservoir.
- ! Overband.
- ! Combination (reservoir and overband).

In the flush fill configuration, material is simply dispensed into the existing, uncut crack and excess material is struck off. Configuration A in figure 6 illustrates the flush fill configuration.

In a reservoir configuration, material is placed only within the confines of a cut crack (i.e., *crack reservoir*). The material is placed either flush with or slightly below the pavement surface. Configurations D, F, H, J, and K in figure 6 are reservoir-type configurations.

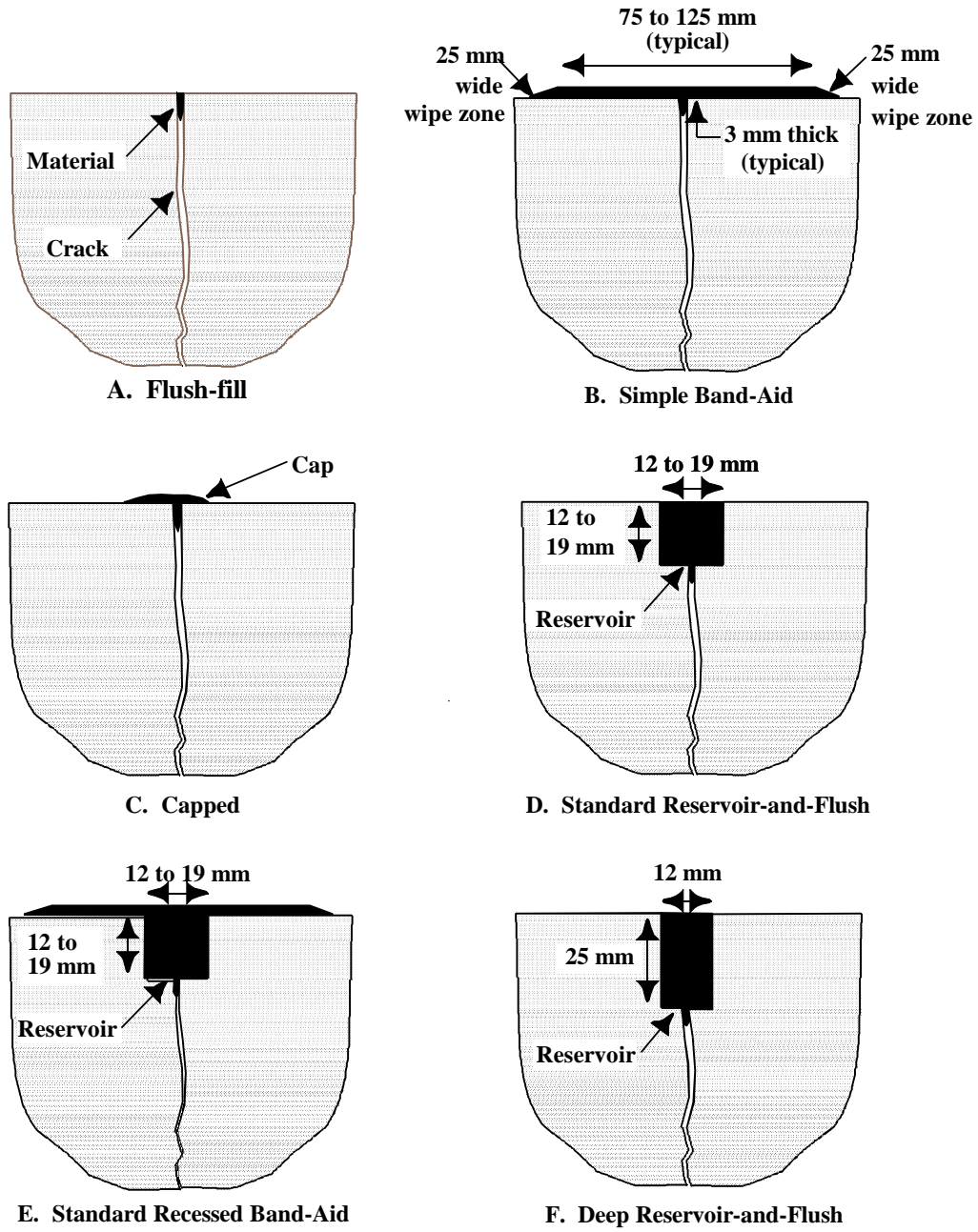
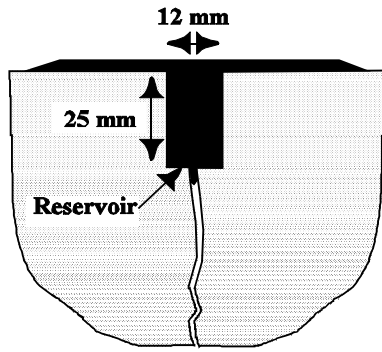
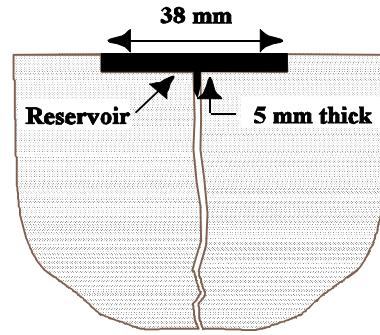

Figure 6. Material placement configurations



G. Deep Recessed Band-Aid



H. Shallow Reservoir-and-Flush

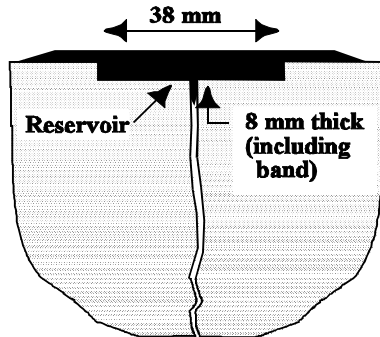

I. Shallow Recessed Band-Aid

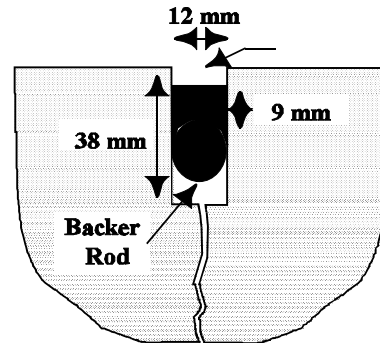

J. Deep Reservoir-and-Recess (backer rod)

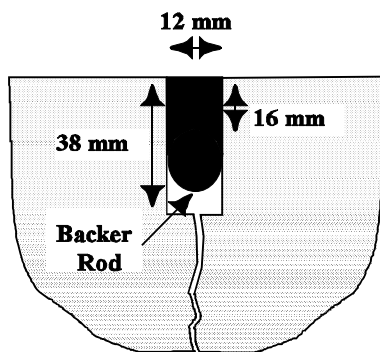

K. Deep Reservoir-and-Flush (backer rod)

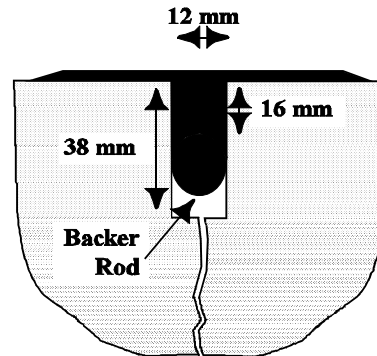

L. Deep Recessed Band-Aid (backer rod)

Figure 6. Material placement configuration (continued).

In an overband configuration, the material is placed into and over an uncut crack. If the material over the crack is shaped into a band using a squeegee, then the simple *band-aid* configuration is formed (configuration B). If the material over the crack is left unshaped, then the *capped* configuration is created (configuration C).

A combination configuration consists of a material placed into and over a cut crack. A squeegee is used to shape the material into a band that is centered over the crack reservoir. Configurations E, G, I, and L in figure 6 are combination-type configurations.

Individual configurations are based on four controlling variables.

1. Type of application.
 - a. Direct—Material applied directly to crack channel.
 - b. Bond-Breaker—Backer material placed at bottom of crack reservoir prior to material installation in order to prevent three-sided adhesion (i.e., bonding by material to crack reservoir bottom and sidewalls).
2. Type of crack channel.
 - a. Uncut.
 - b. Cut—Router or saw used to create uniform crack reservoir.
3. Strike-off or finishing characteristics.
 - a. Recessed.
 - b. Flush.
 - c. Capped.
 - d. Band-aid.
4. Dimensions of crack reservoir and overband.

Nearly all sealing and filling operations have the material applied directly to the crack channel (configurations A through I). Occasionally, however, a bond-breaker material, such as

polyethylene foam backer rod, is placed at the reservoir bottom of a working crack prior to sealant application (configurations J, K, and L). The backer rod prevents sealant material from running down into the crack during application and also from forming a three-sided bond with the reservoir perimeter. As a result, the sealant's potential performance is enhanced.

Sealant shape, particularly for reservoir configurations, also influences performance. It is the primary design consideration and is often dealt with in terms of shape factor. The shape factor is defined as the ratio between the width and depth of the sealant (Peterson, 1982). In direct applications, shape factor is controlled solely by the crack-cutting operation (i.e., cutting width and depth). In backer rod applications, shape factor is controlled by both the cutting operation and the depth to which the backer rod is placed.

Current recommendations for both direct and bond-breaker applications are to give rubber-modified asphalt sealants a shape factor of 1 and silicone sealants a shape factor of 2. Generally, seals with smaller shape factors risk adhesion loss, while those with larger shape factors have increased resistance to adhesion loss.

Bond-breaker application should only be considered when the following two factors apply:

- ! The costs of installing backer rod are anticipated to be lower than the cost benefits of improved performance.
- ! Working cracks are relatively straight (as with joint reflection cracks) and are accompanied by very little edge deterioration.

Most hot-applied rubber-modified sealants are recommended for direct application; the increased costs of using backer rod with these materials is not justified. Silicone is perhaps the only material recommended for placement with backer rod.

A meandering crack is often difficult to follow accurately with cutting equipment. Portions of the crack may occasionally be missed, resulting in two adjacent channels. This presents the dilemma of whether to seal both the cut and uncut crack segments or to cut the missed crack segment and seal both reservoirs. A similar dilemma arises with secondary cracks along the primary crack.

Routers and saws are usually equipped with controls for varying the depth of cut, and the width setting can normally be adjusted manually. Backer rod can be placed in deep reservoirs (25 to 38 mm) to a depth that allows for the desired shape factor. This depth normally varies between 12 and 19 mm. The backer rod should be about 25 percent wider than the width of the crack reservoir for it to maintain its vertical position and provide proper shape for the material.

The decision of whether to overband a sealant or filler material depends primarily on the material being used. Some materials, such as silicone and emulsion, simply must not come in contact with traffic. Also, some materials wear away more easily under traffic than others.

If overbanding of hot-applied, rubber-modified asphalt is desired, it also must be decided if the material will be shaped into a band-aid or left as a capped configuration. The latter process generally means one less laborer, but possibly at the sacrifice of treatment effectiveness. This is because shaping with a squeegee or dish attachment helps in establishing a "hot bond" for the entire band. In capped configurations, the material may continue to flow and level out after being applied.

Bonds occurring as a result of this self-leveling are likely to be weaker because the material will have decreased in temperature.

The dimensions of the band-aid are typically 75 to 125 mm wide and 3 to 6 mm thick. The simple band-aid configuration (configuration B) evolved out of a desire to make application quick and easy by eliminating crack-cutting operations. The recessed band-aid configuration was devised to improve the performance of reservoir-type configurations through the addition of the band as a wearing surface.

Selecting a placement configuration is an involved process. Table 6 offers a few basic considerations to aid the planner.

3.4 Selecting Procedures and Equipment

Crack treatment consists of at least two and up to five steps, depending on the type of treatment (sealing or filling), treatment policy, and available equipment. These steps are:

1. Crack cutting (i.e., routing or sawing).
2. Crack cleaning and drying.
3. Material preparation and application.
4. Material finishing/shaping.
5. Blotting.

Steps 1, 4, and 5 are considered optional. Crack cutting is rarely done in filling operations, but is frequently done in sealing operations. In regions with significant annual temperature variations, typical of many northern States, crack cutting is often performed to achieve material shape factors that can provide added flexibility for withstanding high crack movements.

Table 6. Placement configuration considerations.

Consideration	Applicability
Type and Extent of Operation	Most filling operations, and some sealing operations, omit crack cutting operation. Many northern States find crack cutting necessary or desirable.
Traffic	Overband configurations experience wear and, subsequently, high tensile stresses directly above the crack edges, leading to internal rupture.
Crack Characteristics	Overband configurations are more appropriate for cracks having a considerable amount of edge deterioration (> 10 percent of crack length), because the overband simultaneously fills and covers the deteriorated segments in the same pass.
Material Type	Materials such as emulsion, asphalt cement, and silicone must be placed unexposed to traffic due to serious tracking or abrasion problems.
Desired Performance	For long-term sealant performance, flush, reservoir, and recessed band-aid configurations should be considered.
Aesthetics	Overband and combination configurations detract from the general appearance of the pavement.
Cost	Omission of crack cutting operation reduces equipment and labor costs. Combination configurations require significantly more material than reservoir configurations, resulting in higher costs.

Most crack treatment programs use squeegees to finish or shape the material at the surface; capped and recess configurations require no finishing.

Finally, blotting, in which a temporary covering such as toilet paper, sand, or limestone dust is placed directly on top of the treatment material, may be necessary to prevent tracking. Asphalt emulsions and hot-applied materials placed in overband configurations and prematurely subjected to traffic are prime candidates for blotting.

Many types and brands of equipment are available for crack treatment operations. Table 7 lists the types of equipment commonly used, examples of equipment manufacturers, and general recommendations concerning each piece of equipment. Table 8 provides additional information about the manpower requirements and typical production rates associated with each procedure.

3.4.1 Crack Cutting

Crack cutting is done with routers or saws, as illustrated in figures 7 and 8. However, because crack cutting can inflict additional damage on the pavement and is often the slowest activity in sealing operations, it is desirable to use a high-production machine that follows cracks well and produces minimal spalls or fractures.

The vertical-spindle router is perhaps the least damaging and most maneuverable cutting machine; however, its production rate is quite low. Rotary-impact routers are much more productive than vertical-spindle routers; however, depending on the type of cutting bit used, they can cause considerably more damage. Carbide router bits are highly recommended over steel router bits.

Table 7. Crack treatment equipment characteristics and recommendations.

Operation	Type of Equipment	Recommendations
Crack Cutting	Vertical-Spindle Router	Use only with sharp carbide-tipped or diamond router bits.
	Rotary-Impact Router	Use only with sharp carbide-tipped router bits.
	Random Crack Saw	Use only on fairly straight cracks. Diamond-blade saw, 200-mm maximum diameter.
Crack Cleaning/ Drying	Blowers (Backpack & Power-Driven)	Not recommended —Insufficient blast velocity (60 to 100 m/s).
	Air Compressor	Equipped with oil and moisture filters. Pressure—690 kPa minimum. Flow—0.07 m ³ /s minimum. Velocity—990 m/s minimum.
	Hot-Air Lance	Velocity—610 m/s minimum. Temperature—1370°C minimum. No direct flame on pavement. <u>Highly Recommended</u> Velocity—915 m/s minimum. Temperature—1650°C minimum.
	Sandblaster	Acceptable air compressor (minimum 690 kPa pressure and 0.07 m ³ /s flow). Minimum 25-mm-inside-diameter lines and 6-mm-diameter nozzle.
	Wirebrush	Do not use with worn brushes. Not recommended for cleaning previously treated cracks, as there is a tendency to smear material.

Table 7. Crack treatment equipment characteristics and recommendations (continued).

Operation	Type of Equipment	Recommendations
Material Installation	Pour Pots	Not recommended for production operations.
	Asphalt Distributor	Not suitable for fiber- or rubber-modified asphalt materials.
	Melter-Applicator	Direct-heat kettles not suitable for fiber- or rubber-modified asphalt materials. Indirect-heat kettles should be equipped with: * Double-boiler, mechanical agitator with separate automatic temperature controls for oil and melting chamber. * Sealant heating range to 230°C. * Full-sweep agitator. * Accurately calibrated material and heating oil temperature gauges.
	Backer Rod Installation Tools	Maintains proper recess. Does not damage backer rod.
	Silicone Pump & Applicator	Flow Rate—0.025 L/s minimum. Hose lined with Teflon; all seals and packing made from Teflon.
Material Finishing	Squeegee	Heavy-duty, industrial U- or V-shaped.

Table 8. Typical manpower requirements and production rates for crack treatment operations.

Operation	Equipment	Manpower		Approximate Productivity, linear m/min
		Equipment	Driver	
Crack Cutting	Routing (vertical-spindle router)	1	—	0.5 to 1.0
	Routing (rotary-impact router)	1	—	3.5 to 4.5
	Sawing (diamond-blade crack saw)	1 to 2	—	1.0 to 2.5
Crack Cleaning/ Drying	Airblasting (blowers)	1	—	3.5 to 5.5
	Airblasting (compressed air)	1	1	3.0 to 4.5
	Hot airblasting (hot compressed-air lance)	1	1	1.5 to 3.0
	Sandblasting (sandblaster)	2 to 3	1	1.0 to 1.5 (2 passes)
	Wirebrushing (wirebrush)	1	—	2.5 to 4.0
Material Installation	Drums & pour pots	2 to 3	1	1.5 to 3.0
	Asphalt distributor with wand and hose	2	1	4.5 to 8.0
	Melter-applicator	2	1	4.5 to 8.0
	Backer rod	2	—	2.5 to 4.5
	Silicone pump & applicator	2	1	1.5 to 3.5
Material Finishing	U- or V-shaped squeegee	1	—	7.5 to 10.5
Material Blotting	Sand	1 to 2	0 to 1	3.5 to 5.5
	Toilet paper	1	—	9.0 to 14.0



Figure 7. Rotary-impact router.



Figure 8. Diamond-blade crack saw.

A random crack saw with 150- to 200-mm-diameter diamond blades can follow meandering cracks moderately well. Although its cutting rate is not nearly as high as the rotary-impact router, it provides a more rectangular reservoir with smoother walls and a higher percentage of aggregate surface area.

3.4.2 Crack Cleaning and Drying

Crack preparation procedures are the techniques used to clean or dry crack channels to attain the best conditions possible for the material to be placed. It is perhaps the most important aspect of sealing and filling operations because a high percentage of *treatment failures* are adhesion failures that result from dirty or moist crack channels.

The four primary procedures used in preparing crack channels are airblasting, hot airblasting, sandblasting, and wirebrushing. These procedures are discussed in the following sections.

Airblasting

Airblasting is done with one of two types of equipment:

- ! Portable backpack or power-driven blowers.
- ! High-pressure air compressors with hoses and wands.

Backpack and power-driven blowers are generally used to clean pavement surfaces prior to sealcoating. However, they have been used to clean cracks. These blowers deliver high volumes of air at low pressures. As a result, blast velocity is generally limited to between 75 and 110 m/s. Although blowers require only one laborer and provide better mobility, the high-pressure (>690 kPa) capabilities of compressed-air units make them more desirable than blowers for crack cleaning.

High-pressure airblasting (figure 9) is fairly effective at removing dust, debris, and some loosened AC fragments. However, it is not nearly as effective in removing laitance or in drying the crack channel.

Compressed-air units should have a minimum blast pressure of 690 kPa and a blast flow of 0.07 m³/s. In addition, compressed-air units equipped with oil- and moisture-filtering systems are highly recommended, as the introduction of oil or moisture to the crack channel can seriously inhibit bonding of the sealant to the sidewall.

Hot Airblasting

Hot airblasting is performed with a hot compressed-air (HCA) lance, or heat lance, connected to a compressed-air unit, as shown in figure 10. This form of crack preparation is quite effective at removing dirt, debris, and laitance. Moreover, the extreme heat it delivers to a crack provides two benefits. First, crack moisture is quickly dissipated, thereby improving the potential for bonding of the sealant or filler material. Second, assuming the material installation operation follows closely behind the hot airblasting operation, the heated crack surface can enhance bonding of hot-applied sealant or filler materials.

There are a number of HCA lance models available on the market today, each with its own heat and blast capacities and operational control features (e.g., push-button ignition, wheels, balancing straps). Minimum requirements for these units should be a 1370°C heat capacity and a 610-m/s blast velocity.



Figure 9. High-pressure airblasting using compressed air.



Figure 10. Hot airblasting using HCA (heat) lance.

Heat lances with high heat and blast velocity (1650°C and 915 m/s) are preferred for production operations. However, caution must be exercised with these units to avoid burning the AC pavement. Finally, direct-flame torches should never be used, and air compressors used in hot airblasting operations should be equipped with oil- and moisture-filter systems.

Sandblasting

Sandblasting is a labor-intensive operation that is quite effective at removing debris, laitance, and loosened AC fragments from the sidewalls of sawn cracks. The procedure, depicted in figure 11, leaves a clean, textured surface that is ideal for bonding.

Sandblasting equipment consists of a compressed-air unit, a sandblast machine, hoses, and a wand with a Venturi-type nozzle. A second air compressor is often necessary for follow-up cleaning after the sandblasting operation.



Figure 11. Sandblasting operation.

The compressed air supply is the most critical part of a sandblasting operation. At least 690 kPa of pressure and 0.07 m³/s of oil- and moisture-free air volume should be provided. Large air supply and sandblast hoses should also be used to reduce friction losses and resulting pressure drops. A minimum of 25-mm-inside-diameter lines and a 6-mm-diameter nozzle orifice size are recommended.

Wirebrushing

Occasionally, sawn or routed cracks are cleaned using mechanical, power-driven wirebrushes in conjunction with some form of compressed air. Depending on the brush and bristle characteristics, this combination is quite effective at removing debris lodged in the crack reservoir, but not as effective at removing laitance and loosened AC fragments from the crack sidewalls.

Wirebrushes are available commercially, with and without built-in airblowers. Some agencies have had success modifying pavement saws by removing the sawblades and attaching wirebrush fittings to the rotor of the machine.

3.4.3 Material Preparation and Application

Bond-Breaker Installation

The simplest and easiest tool for placing backer rod is one equipped with two roller wheels and an adjustable central insertion wheel, as illustrated in figure 12. This type of tool generally accommodates a threaded broom handle and comes with additional insertion wheels of various widths.



Figure 12. Backer rod installation tool.

Cold-Applied Thermoplastic Bituminous Materials

Emulsion materials can be prepared and applied in various ways. They can be loaded into distributors for partially heated application or kept in drums for unheated application. Distributors are often equipped with pressure or gravity hoses for wand application. Hand-held or wheeled pour pots may be used to apply heated or unheated emulsion in the cracks.

Determining which method to use for preparing and installing emulsion depends primarily on the availability of equipment. However, the need for partial heating and the size of the job must also be considered.

Hot-Applied Thermoplastic Bituminous Materials

Material heating for hot-applied thermoplastic bituminous materials is usually done with an asphalt distributor or an asphalt kettle/melter, similar to that shown in figure 13. Unmodified asphalt materials, such as asphalt cement, are usually heated and placed using distributors or direct-heat kettles. These units typically burn propane gas for heat, and the heat is applied directly to the melting vat containing the asphalt material. The direct-heat system is not recommended for heating modified asphalt materials as it can cause uneven heating or overheating of the asphalt, particularly when no agitation devices are available.

Rubber- and fiber-modified asphalt materials must be heated and mixed in indirect-heat, agitator-type kettles. These machines burn either propane or diesel fuel, and the resulting heat is applied to a transfer oil that surrounds a double-



Figure 13. Asphalt kettle with pressure applicator.

jacketed melting vat containing the treatment material. This indirect method of heating is safer and provides a more controlled and uniform way to heat the material. Agitation devices are usually standard equipment on these units.

As with other crack treatment equipment, several types and sizes of asphalt kettles are available and in use. Some items that should be considered when determining which kettle to use include the following:

- ! Type of material.
- ! Size of job.
- ! Constraints on preparation time.
- ! Air temperature during preparation.
- ! Safety.

Rubber-modified asphalt sealants can be adequately heated and applied by most indirect-heat kettles equipped with pressure applicators. However, because of their thick consistency, fiberized asphalt materials often require the use of kettles with heavy-duty application pumps, large hoses, and full-sweep agitation equipment. A 15-kW engine is generally recommended for fiberized applications, along with a 50-mm recirculating pump and discharge line.

For small jobs, a small-capacity kettle (380 L maximum) is desirable. Since it is generally recommended that kettles be filled to at least one-third of their capacity to avoid overheating the material and to allow effective operation, large-capacity kettles would not be appropriate because more material would be heated than necessary.

Unless the kettle operator begins work several hours prior to normal starting time, material heating time can substantially cut into operational time. This is particularly true in cold weather and when using large kettles. Depending on the amount of

material prepared, large kettles (1,515 L or greater) may take as long as 3 hours to bring a material to application temperature. Conversely, small kettles (190 to 380 L) usually take between 60 and 75 min.

In general, kettles should allow the operator to regulate material temperatures up to 220°C. Accurate thermostats should monitor both the material and heating oil temperatures, and these thermostats should control the operation of the burners. The kettle should allow recirculation of materials back into the vat during idle periods. Insulated applicator hoses and wands are recommended, and hoses should meet or exceed the kettle manufacturer's specifications.

Cold-Applied Thermosetting Materials

Silicone pumps must be capable of being directly attached to the original material container, typically a 19- or 208-L drum. Pumps and applicators should provide sealant to the crack at a rate that does not limit the operator; 0.03 L/s is recommended as a minimum flow rate. Teflon-lined application hoses and seals are also recommended because they are able to prevent silicone from curing in the pump or hose.

3.4.4 Material Finishing/Shaping

Material finishing can be accomplished in two ways. First, various sizes of dish-shaped attachments are available that can be connected to the end of the application wand for one-step application and finishing. Second, industrial rubber squeegees, like the one shown in figure 14, can be used behind the material applicator to provide the desired shape.

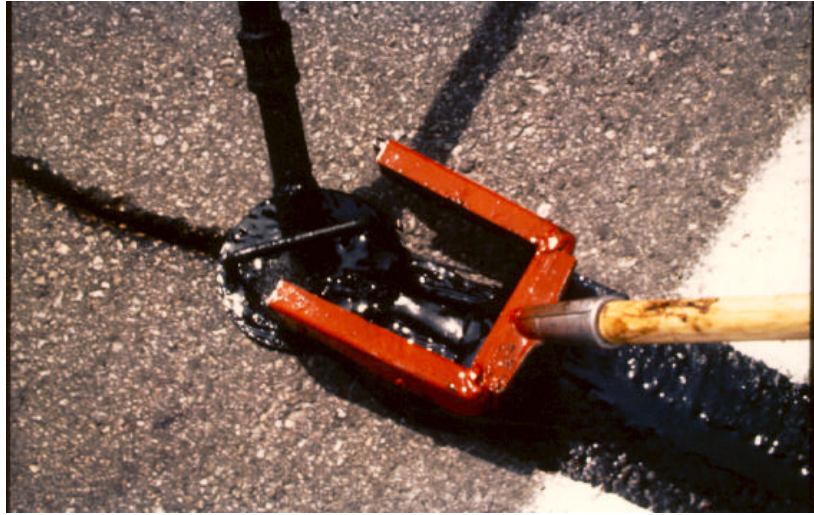

Figure 14. Industrial squeegee molded into a “U” shape.

The one-step method requires one less worker, but often does not provide as much control in finishing as the squeegee method, especially for overband configurations.

3.4.5 Material Blotting

The equipment necessary for blotting depends on the type of blotter material to be used. Sand will generally require a truck or trailer on which it can be stored, along with shovels for spreading.

Toilet paper can often be loaded on the same truck with the prepackaged sealant blocks. Rolls of toilet paper can then be placed on a modified paint roller (equipped with a long handle) for easy application.

3.5 Estimating Material Requirements

Although maintenance agencies frequently purchase a year's supply of one or two materials, reliable estimates of material necessary for a particular project can be very useful in attempting to use the right material in each situation. The worksheet in figure 15 should help the crack treatment planner compute how much material to acquire for a project. An example calculation is provided in appendix B.

3.6 Cost-Effectiveness Analysis

Although performance is important, cost-effectiveness is often the preferred method of determining which materials and procedures to use. Obviously, a treatment that costs \$15/m in-place and performs adequately for 5 years is more desirable than a treatment that costs \$30/m in-place and performs for the same amount of time. However, this philosophy has limits. For instance, even if biannual applications of asphalt cement were determined to be the most cost-effective treatment alternative, it would most likely be impractical because crews would be restrained from tending to other activities and would be placed in harm's way much more often.

The worksheet in figure 16 should assist the planner in computing treatment cost-effectiveness. An example of how to compute cost-effectiveness with this worksheet is provided in appendix C.

Determining Material Quantity Requirements	
A. Length of section to be treated.	_____ m
B. Length of sample segment inspected.	_____ m
C. Amount (length) of targeted crack in sample segment inspected.	_____ lin m
D. Amount (length) of targeted crack in section. D = C × (A/B)	_____ lin m
E. Average estimated width of targeted crack.	_____ mm
F. Type of material configuration planned.	_____
G. Cross-sectional area of planned configuration.	_____ mm ²
H. Total volume in m ³ of targeted crack to be treated. H = (G/10 ⁶) × D	_____ m ³
I. Total volume in L of targeted crack to be treated. I = H × 1000 L/m ³	_____ L
J. Unit weight of planned treatment material in kg/L.	_____ kg/L
K. Theoretical amount of material needed in kg. K = J × I	_____ kg
L. Total material amount recommended with ___ % wastage. L = 1. ___ × K	_____ kg

Figure 15. Worksheet for determining material quantity requirements.

Crack Treatment Cost-Effectiveness

- A. Cost of purchasing and shipping material in \$/kg. \$ _____ /kg
- B. Application rate in kg/lin m (including wastage). _____ kg/lin m
- C. Placement cost (labor & equipment) in \$/day. \$ _____ /day
- D. Production rate in lin m of crack per day. _____ lin m/day
- E. User delay cost in \$/day. \$ _____ /day
- F. Total installation cost in \$/lin m.
 $F = (A \times B) + (C/D) + (E/D)$ \$ _____ /lin m
- G. Interest rate. _____ percent
- H. Estimated service life of treatment in years
 (time to 50 percent failure). _____ years
- I. Average annual cost in \$/lin m.
- $$I = F \times \frac{G \times (1 + G)^H + (1 + G)^H - 1}{(1 + G)^H - 1}$$
- \$ _____ /lin m

Figure 16. Cost-effectiveness computation worksheet.

4.0 Construction

Once the most appropriate material and placement procedure are selected, proper field application must be carried out. The best method for achieving proper application is to ensure that the objective of each step in the crack treatment operation is met. Toward this end, crews should be fully aware of what they are expected to do and of the importance of what they will be doing. Likewise, supervisors/inspectors must know what to expect as a result of each operation.

This chapter presents the fundamental objective of each operational step and provides general guidance on how the operations should be performed to best meet the objectives. Operational checklists that help both crews and supervisors/inspectors monitor work quality are provided in appendix D.

4.1 Traffic Control

Whether it's provided as a moving operation or a stationary work zone, good traffic control is necessary to provide a safe working environment for the installation crew and a safe, minimally disruptive travel path for traffic.

The appropriate traffic control setups are usually stipulated by departmental policies. However, a quick survey of the roadway to be treated can be helpful for identifying any special precautions needed, as well as any additional safety equipment needed during the installation. Flag persons are often needed on operations that encroach into adjacent traveled lanes, particularly on moderately and highly trafficked highways. Such operations often include crack cutting, crack cleaning, and squeegeeing.

4.2 Safety

Another aspect of safety is worker protection from material and equipment hazards. Mandated highway safety attire, such as vests and hard hats, should always be worn by crews and foremen during operations. In addition, individual crews should be made aware of all safety precautions associated with the particular materials and equipment they are using. A more detailed account of material and equipment safety is provided in appendix E.

4.3 Crack Cutting

Objective: To create a uniform, rectangular reservoir, centered as closely as possible over a particular crack, while inflicting as little damage as possible on the surrounding pavement.

If crack cutting is to be performed, saw blades or router bits must be checked for sharpness and sized or spaced to produce the desired cutting width. Most cutting equipment has mechanical or electric-actuator cutting depth controls and depth gauges for quick depth resetting. The desired cutting depth and corresponding gauge setting should be established prior to formal cutting of cracks.

Regardless of the type of cutting equipment used, every effort should be made to accurately follow the crack while cutting. Even though production may be considerably compromised on meandering cracks, missed crack segments, such as those shown in figure 17, can be minimized and high performance potential can be maintained. Centering the cut over the crack as much as possible provides added leeway when cutting.



Figure 17. Crack segment missed by cutting equipment.

If a secondary crack is encountered along a primary crack, such as that shown in figure 18, a decision must be made as to whether to cut it. Two closely spaced channel cuts can significantly weaken the integrity of the AC along that particular segment. A general rule is to cut only secondary cracks spaced farther than 300 mm from a primary crack. Secondary cracks closer than 300 mm should be cleaned and sealed only.

4.4 Crack Cleaning and Drying

Objective: To provide a clean, dry crack channel, free of loosened AC fragments, in which the crack treatment material and any accessory materials can be placed.



Figure 18. Primary crack accompanied by secondary crack.

Crack-cleaning operators are likely to encounter some loosened AC fragments while cleaning, particularly if cracks are cut. Operators should remove these fragments because they will be detrimental to sealant or filler performance. If the cleaning equipment is unable to remove these fragments, they should be removed manually with hand tools.

Finally, the cutting operator should periodically inspect newly created reservoirs for shape and size. Cold temperatures, coarse AC mixes, or dull cutting elements can lead to spalled crack edges or highly distorted rectangular channels. These have an adverse effect on material performance.

4.4.1 High-Pressure Airblasting

Because high-pressure airblasting provides no heat and very little drying, it should only be performed when the pavement and crack channels are completely dry and when ambient temperatures are above 4°C and rising. Furthermore, since many modern air compressors are known to introduce water and oil into the air supply, compressors should be equipped with moisture and oil filters that effectively remove these contaminants.

High-pressure airblasting equipment must be able to provide a continuous, high-volume, high-pressure airstream using clean, dry air. Recommended operational criteria are 690 kPa pressure and 0.7 m³/s flow.

Operators should make at least two passes of high-pressure airblasting along each crack or crack segment. The first pass dislodges loose dirt and debris from the crack channel. The wand should be held no less than 50 mm away from the crack. The second pass completely removes all the dislodged crack particles from the roadway and shoulder. In this pass, the wand can be held further away from the pavement surface to make use of a larger blast area.

High-pressure airblasting should be conducted just ahead of the sealing or filling operation. The greater the time interval between these two operations, the more likely dust and debris will resettle in the crack channel.

4.4.2 Hot Airblasting

Unlike high-pressure airblasting, hot airblasting can be used in both ideal and partly adverse conditions for cleaning, drying, and warming cracks. Its most practical applications include drying damp cracks resulting from overnight dew or a short

sprinkle and warming cracks below 10°C to promote bonding with hot-applied materials. However, a heat lance should not be used as part of a crack treatment operation being conducted during rainshowers or in saturated pavement conditions.

Heat lances should provide a continuous stream of hot, high-pressure air with no flame at the exit nozzle. As stated earlier, units with high heat and blast capabilities (1650°C and 915 m/s) are recommended, but must be used with extreme caution so that the AC pavement is not burned.

Like high-pressure airblasting, hot airblasting should be conducted in two steps. A first pass, made along the crack in a steady fashion, should clean and heat, but not burn, the crack sidewalls (and surrounding pavement if material is to be overbanded). The heat lance should be held approximately 50 mm above the crack channel. Proper heating is manifested by a slightly darkened color; burning is apparent by a black color and a very gritty texture. The second pass completely removes all the dislodged crack particles from the roadway and shoulder.

Hot airblasting should be conducted immediately ahead of the sealing or filling operation. This will not only limit the amount of dust and debris blown into the cleaned crack channel, but it will also maximize crack warmth and minimize the potential for the formulation of moisture condensation in the crack channel. The less time between the two operations, the greater the bonding potential of the sealant or filler material.

4.4.3 Sandblasting

Sandblasting operations should be done in dry weather and should be followed up by airblasting to remove abrasive sand from the crack reservoir and roadway. The sandblasting equipment must be capable of removing dirt, debris, and sawing residue with a correctly metered mixture of air and abrasive sand.

A minimum of 690 kPa and 0.7 m³/s of oil- and moisture-free air should be supplied to the sandblaster, such that a minimum nozzle pressure of 620 kPa is maintained. In addition, 25-mm-inside-diameter hoses and a 6-mm-diameter nozzle orifice are recommended.

One pass of the sandblaster should be made along each side of the crack reservoir. The flow of air and sand should be directed toward the surfaces (generally crack sidewalls), which will form bonds with the sealant material. In general, the wand should be kept 100 to 150 mm from the crack channel to provide optimal cleaning without damaging the integrity of the crack reservoir. An adjustable guide, such as that shown in figure 19, can be attached to the nozzle to consistently provide the desired results and reduce operator fatigue.

4.4.4 Wirebrushing

Power-driven, mechanical wirebrushes should be used only for cleaning dry crack channels that possess very little laitance. They must be able to closely follow the crack and should be supplemented with some form of airblasting. In addition, brush attachments should contain bristles flexible enough to allow penetration into the crack channel, yet rigid enough to remove dirt and debris.



Figure 19. Sandblasting wand with wooden guide attached.

As with saws and routers, most mechanical wirebrushes have actuator-type depth-control switches. The absence of depth gauges, however, usually requires frequent setting adjustments for optimal cleaning of each new crack.

4.5 Material Preparation and Application

Objective: To install any accessory materials into the crack channel, prepare the crack treatment material for recommended application, and place the proper amount of material into or over the crack channel to be treated.

The material installation operation must follow closely behind the crack cleaning and drying operation in order to ensure the cleanest possible crack channel.

4.5.1 Installing Backer Rod

If bond-breaker sealant application is specified, backer rod may be installed only after the crack reservoir and pavement surface have been adequately cleaned. The recommended method of installing backer rod is as follows:

1. Adjust the insertion disk on the backer rod installation tool to the appropriate depth for placement. The depth should be slightly greater than the required depth of backer rod because the rod compresses slightly when installed.
2. Reel out a sufficient amount of backer rod from the spool to cover the length of the crack.
3. Insert the end of the rod into one end of the crack reservoir.
4. Tuck the rod loosely into the reservoir at various points along the crack, leaving a little slack in the rod between points. Stretching and twisting of the backer rod should be avoided where possible.
5. Starting from the end, push the rod into the reservoir to the required depth using the installation tool. It will be necessary during this time to periodically take out any slack in the rod that might have developed or already existed.
6. Roll over the rod a second time with the installation tool to ensure proper depth.
7. Cut the rod to the proper length, making sure no gaps exist between segments of backer rod.
8. If segments of the crack reservoir are wider than the rod, it will be necessary to either place additional pieces of rod or install larger diameter backer rod in those sections.

4.5.2 Material Preparation

Every crack treatment material requires some form of preparation, whether it's loading the material into the applicator, heating it to the appropriate temperature, or mixing it for proper consistency and uniform heating. While this manual presents some basic guidelines for the preparation and installation of materials, the specific recommendations provided by the manufacturer of the material to be placed should be followed closely. These recommendations generally pertain to items such as minimum placement temperature, material heating temperatures, prolonged heating, and allowable pavement temperature and moisture conditions.

The best placement conditions for most materials are dry pavement and an air temperature that is at least 4°C and rising. However, the use of a heat lance will usually permit many hot-applied materials to be placed in cold or damp conditions, as discussed earlier. Some emulsion materials can be placed in temperatures below 4°C, but the threat of rain generally precludes their placement because they are susceptible to being washed away by water.

Two temperatures are important to monitor while preparing hot-applied materials:

- ! **Recommended Application Temperature**—The temperature of the material at the nozzle that is recommended for optimum performance.
- ! **Safe Heating Temperature**—The maximum temperature that a material can be heated to before experiencing a breakdown in its formulation.

Recommended application temperatures for hot-applied asphalt materials generally range from 188 to 200°C. Notable

exceptions include some fiberized asphalt materials that must be applied at temperatures in the range of 138 to 160°C. Emulsions may be applied at ambient temperature or may be partially heated to between 52 and 66°C.

Prior to heating a material, kettle operators should know its safe heating temperature and the effects of overheating or extended heating. Safe heating temperatures for hot-applied materials are typically 11 to 17°C higher than recommended application temperatures. The effects of overheating or extended heating depend on the specific material. Some materials exhibit a thickened, gel-like consistency, while others thin out or soften considerably. In either case, the material should be discarded and new material should be prepared.

Other preparation-related concerns for hot-applied materials include prolonged heating and reheating as a result of work delays. Most hot-applied materials have prolonged heating periods between 6 and 12 hours, and they may be reheated once. In both instances, more material should be added, if possible, to extend application life.

Substantial carbon buildup should be cleaned off the melting vat walls before an asphalt kettle is used. In addition, all temperature gauges on the unit should be calibrated to display exact temperatures. An ASTM 11F or equivalent thermometer should be available for verifying material temperatures in the kettle and measuring material temperatures at the nozzle. Hand-held, calibrated infrared thermometers can be used to easily check sealant, air, and pavement temperatures.

A few guidelines for initial heating of hot-applied materials include the following:

1. Heating should begin so that the material is ready by the time normal work operations begin.

2. Heating oil temperature should be kept no more than 28 to 42°C above the safe heating temperature of the material, depending on the material manufacturer's recommendation.
3. Material temperatures must remain below the recommended pouring temperature.
4. The agitator should be started as soon as possible.

An emulsion material that is applied cold from the original container may need to be mixed if asphalt particles have settled during storage. Simple stirring at the bottom of the container will bring the material to a uniform consistency.

4.5.3 Material Application

Hot-pour application should commence once the material has reached the recommended application temperature and the first few cracks have been prepared. From here, the focus is on three items:

- ! Consistently maintaining the material at or near the recommended application temperature without overheating.
- ! Maintaining a sufficient supply of heated material in the kettle.
- ! Properly dispensing the right amount of material into the crack channels.

The kettle operator must be fully aware of the recommended application temperature and the safe heating temperature of the material being installed. These temperatures are generally marked on the material containers for quick and easy reference.

Maintaining a consistent material temperature can be rather difficult, especially in cold weather. Underheated material may produce a poor bond or freeze the application line, causing a

work delay. Overheating, on the other hand, will lead to either poor treatment performance or a suspended operation.

Guidelines for maintaining hot-applied material in a sufficient quantity and at the proper temperature during application are as follows:

1. Check the temperature of the material at the nozzle and in the melting vat using a high-temperature thermometer attached to a metal or wooden rod or a hand-held infrared thermometer.
2. Adjust the heating controls to reach the recommended application temperature (or as near as possible without exceeding the safe heating temperature).
3. Regularly check the sealant temperatures and adjust as necessary.
4. Watch for carbon buildup on the sidewalls of the heating chamber and visually inspect material for changes in consistency.
5. Periodically check the level of material in the melting vat. Add material as needed.

The application procedure for all crack treatment materials is basically the same, regardless of what application device is used. Pressure applicators are almost always used; however, pour pots are occasionally used for applying cold-applied emulsion materials. In all cases, a relatively free-flowing material must be poured into, and possibly over, the crack channel.

General guidelines for material application include the following:

1. Apply the material with the nozzle in the crack channel, so that the channel is filled from the bottom up and air is not trapped beneath the material.

2. Apply the material in a continuous motion, being sure to fill the channel to the proper level for recessed configurations or provide a sufficient amount of material for flush, capped, or overbanded configurations.
3. Reapply material to crack segments where material has sunk into the crack or an insufficient amount was furnished in the previous pass.
4. Recirculate material through the wand into the melting vat during idle periods.

4.5.4 Asphalt Kettle Cleanout

At the end of each day's work, the applicator system lines on asphalt kettles must be purged of hot-pour material. In addition, if non-reheatable materials are being used, material left in the melting vat must be removed. In any case, the amount of material in the melting vat should be monitored so that as little material as possible remains when work is finished for the day.

When using reheatable materials, the applicator lines can be purged of material using either reverse flow or air cleanout procedures. Thorough cleaning can be accomplished using reverse flow procedures followed by solvent flushing procedures.

When using non-reheatable materials, as much material as possible should be placed in cracks at the project site. Any leftover material will have to be discharged into containers for subsequent disposal. Solvent may then be added and circulated through the system to flush out any excess material.

If flushing solvents are used in cleanout, the kettle operator must ensure that they do not contaminate the sealant or filler material. Step-by-step instructions on how to clean kettles and applicator lines are generally found in the kettle manufacturer's operations manual.

4.6 Material Finishing/Shaping

Objective: To shape or mold the previously applied material to the desired configuration.

Prior to installation, the finishing tool should be tested to ensure that the desired configuration is achieved. If a dish attachment is to be used on the applicator wand, it should be the proper size and aligned to facilitate application.

Squeegees should be properly molded into a "U" or "V" shape so that the material can be concentrated over the crack. If the strike-off is to be flush, the rubber insert should be flat. If a band-aid configuration is required, the rubber insert should be cut to the desired dimensions. The depth of the cut should be a little larger than the desired thickness of the band because some thickness will be lost as a result of the squeegee being pushed forward and slightly downward.

A few recommendations for finishing are as follows:

1. Operate the squeegee closely behind the wand. If the material is runny enough to sink into the crack or flow from the mold provided by the squeegee, maintain a little distance to allow for reapplication or material cooling.
2. Concentrate on centering the application dish or band-aid squeegee over the crack channel.
3. Keep the squeegee free from material buildup by regularly scraping it on the pavement. It may be necessary periodically to remove built-up material with a propane torch.

4.7 Material Blotting

Objective: To apply a sufficient amount of blotter material to protect the uncured crack treatment material from tracking.

When rubber-modified asphalt materials must be blotted to prevent tracking, toilet paper, talcum powder, and limestone dust are often used. These blotters should be applied immediately after finishing so that they can stick to the material and serve as temporary covers. Care must be taken not to overapply dust and powder materials.

Sand is used primarily as a blotter for many emulsion materials and occasionally asphalt cement. It should be applied in a thin layer and should fully cover the exposed treatment material.

5.0 Evaluating Crack Treatment Performance

Monitoring the performance of crack treatments is good practice, and it can be done rather quickly (1 or 2 hours) with fair accuracy. At least one inspection should be made each year to chart the rate of failure and plan for subsequent maintenance. A mid-winter evaluation is highly recommended, as it will show treatment effectiveness during a time of near maximum pavement contraction and near maximum crack opening.

As in the initial pavement/crack survey, a small representative sample of the pavement section, about 150 m, should be selected for the evaluation. The sealant or filler material in each crack within the sample section should then be visually examined to determine how well the material is performing its function of keeping out water.

Items signifying treatment failures include the following:

- ! Full-depth adhesion loss.
- ! Full-depth cohesion loss.
- ! Complete pull-out of material.
- ! Spalls or secondary cracks extending below treatment material to crack.
- ! Potholes.

A good estimate of the percentage of treatment failure can be calculated by measuring and summing the lengths of failed segments and dividing this figure by the total length of treated cracks inspected.

$$\% \text{ Fail} = 100 \times L_f / L_t \qquad \text{Eq. 1}$$

where: $\%Fail$ = Percentage of treatment length failed.
 L_f = Length of treatment failure, m.
 L_t = Total treatment length, m.

Treatment effectiveness can then be determined by subtracting the percentage of treatment failure from 100 percent.

$$\% Eff = 100 - \% Fail \quad \text{Eq. 2}$$

where: $\% Eff$ = Percentage of treatment length that is effective.
 $\% Fail$ = Percentage of treatment length failed.

After a few inspections, a graph of effectiveness versus time can be constructed, like the one shown in figure 20. A minimum allowable effectiveness level—say 50 or 75 percent—will help indicate when future maintenance should be performed.

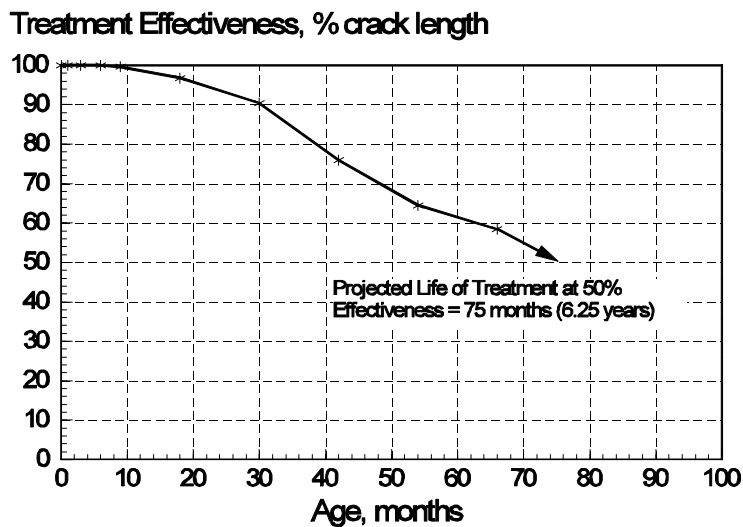

Figure 20. Example graph of treatment effectiveness versus time.

Appendix A

Material Testing Specifications

This appendix presents testing specifications for the primary material types used for sealing cracks. These criteria are based on specifications prepared by national agencies, such as ASTM and AASHTO, State highway agencies, and material manufacturers. Specifications are revised frequently, and the sponsoring agency should be contacted to obtain the latest edition.

ASTM Specifications

American Society for Testing and Materials
100 Barr Harbor Drive
West Conshohocken, PA 19428
(610) 832-9500
www.astm.org

AASHTO Specifications

The American Association of State Highway and
Transportation Officials
444 North Capitol Street NW, Suite 249
Washington, D.C. 20001
www.aashto.org

U.S. Federal Specifications

National Technical Information Service
5285 Port Royal Road
Springfield, VA 22161
(800) 553-6847
www.ntis.gov
www.fhwa.dot.gov

Table A-1. Asphalt rubber specifications.

Test	ASTM D 5078 Test Criteria
Cone penetration (25°C), dmm	70 max
Cone penetration (4°C), dmm	15 min
Resilience (25°C), % recovery	30 min
Softening point, °C	150 min
Asphalt compatibility	Pass

Table A-2. Self-leveling silicone specifications.

Test	Test Method	ASTM D 5893 Test Criteria ^a
Extrusion Rate, mL/min	ASTM C 1183	\$ 50
Tensile stress at 150% strain (23°C), kPa	ASTM D 412(C)	# 310
Rheological properties	ASTM D 2202	Type 1, smooth
Tack-Free Time, h	ASTM C 679	# 5
Bond (-29°C, 100% extension, immersed, non-immersed, oven-aged)	ASTM D 5893	Pass
Hardness (-29°C, type A2)	ASTM C 661	# 25
Hardness (23°C, type A2)	ASTM C 661	\$ 30
Flow	ASTM D 5893	No flow
Ultimate elongation, %	ASTM D 412(C)	\$ 600
Accelerated weathering	ASTM C 793	Pass
Resilience, %	ASTM D 5893	\$ 75

^a Based on 21-day cure time.

Table A-3. Rubberized asphalt specifications.

Test	Test Criteria						
	Previous Standard			Current Standard			Low Modulus
	ASTM D 1190	AASHTO M 173	Federal SS-S-164	ASTM D 3405	AASHTO M 301	Federal SS-S-1401	State Specification
Cone penetration (25°C), dmm	# 90	# 90	# 90	# 90	# 90	# 90	110 to 150
Flow (60°C), mm	# 5	# 5	# 5	# 3	# 3	# 3	# 3
Resilience (25°C), % recovery				\$ 60	\$ 60	\$ 60	\$ 60
Bond (-18°C, 50% extension)	Pass 5 cycles	Pass 5 cycles	Pass 5 cycles				
Bond (-18°C, 100% extension) or (-29°C, 50% extension)						Pass 3 cycles	
Bond (-29°C, 100% extension) or (-29°C, 200% extension)				Pass 3 cycles	Pass 3 cycles		Pass 3 cycles
Asphalt compatibility						Pass	
Cone penetration (-18°C), dmm							\$ 40

Appendix B

Determining Material Quantity Requirements

The following is an example of how to calculate the amount of sealant or filler material needed for a project.

A pavement/crack survey reveals the following information about a particular pavement section:

Project length: 12.88 km or 12,880 m.

Length of sample segment: 152 m.

Length of targeted crack in segment: 61 m.

Average width of targeted crack: 6 mm.

A rubberized asphalt product with a unit weight of 1.18 kg/L will be placed in the shallow reservoir-and-flush configuration (configuration H, figure 6). A 15 percent waste factor is assumed.

Calculation of the amount of material required is shown in figure B-1.

A. Length of section to be treated.	<u>12,880 m</u>
B. Length of sample segment inspected.	<u>152 m</u>
C. Amount (length) of targeted crack in sample segment inspected.	<u>61 lin m</u>
D. Amount (length) of targeted crack in section. D = C × (A/B)	61 × (12,880/152) = <u>5,168 lin m</u>
E. Average estimated width of targeted crack.	<u>6 mm</u>
F. Type of material configuration planned.	<u>Shallow Reservoir & Flush</u>
G. Cross-sectional area of planned configuration. 5 mm deep × 38 mm wide =	<u>190 mm²</u>
H. Total volume in m ³ of design crack to be treated. H = (G/10 ⁶) × D	(190/10 ⁶) × 5,168 = <u>0.98 m³</u>
I. Total volume in L of design crack to be treated. I = H × 1,000 L/m ³	0.98 × 1,000 = <u>980 L</u>
J. Unit weight of planned treatment material in kg/L.	<u>1.18 kg/L</u>
K. Theoretical amount of material needed in kg. K = I × J	980 × 1.18 = <u>1,156 kg</u>
L. Total amount of material recommended with 15 percent overage. L = 1.15 × K	1.15 × 1,156 = <u>1,329 kg</u>

Figure B-1. Solution to material requirements problem.

Appendix C

Sample Cost-Effectiveness Calculations

The following is an example illustration of how material cost-effectiveness can be computed using the worksheet provided in figure 16. In the exercise, two different treatment options are being considered by an agency for an AC transverse crack sealing project.

Option #1

Rubberized asphalt, unit weight = 1.14 kg/L or 1,140 kg/m³.
Standard recessed band-aid configuration (see figure 6).
Material and shipping cost: \$1.43/kg.
Estimated production rate: 762 lin m of crack per day.
Estimated service life: 3 years.

Option #2

Low-modulus rubberized asphalt, unit weight = 1.07 kg/L or 1,070 kg/m³.
Shallow recessed band-aid configuration (see figure 6).
Material and shipping cost: \$1.90/kg.
Estimated production rate: 915 lin m of crack per day.
Estimated service life: 5 years.

The following assumptions are made for both options:

- ! Same wastage factors (15 percent).
- ! 10 laborers each @ \$120/day.
- ! 1 supervisor @ \$200/day.
- ! Equipment costs = \$500/day.
- ! User delay cost = \$2,000/day.

Application rates are computed on the following page, and the actual cost-effectiveness analysis is illustrated in figure C-1.

Option #1

Cross-sectional area
of reservoir $= (13 \text{ mm} \times 13 \text{ mm}) + (102 \text{ mm} \times 3 \text{ mm})$
 $= 475 \text{ mm}^2 (0.000475 \text{ m}^2)$

Volume of reservoir
(1 lin m of crack) $= 1 \text{ m} \times 0.000475 \text{ m}^2$
 $= 0.000475 \text{ m}^3$

Gross Application
Rate (no waste) $= 1,140 \text{ kg/m}^3 \times 0.000475 \text{ m}^3$
 $= 0.54 \text{ kg/lin m of crack}$

Net Application
Rate (15% waste) $= 1.15 \times 0.54 \text{ kg/lin m}$
 $= 0.62 \text{ kg/lin m of crack}$

Option #2

Cross-sectional area
of reservoir $= (38 \text{ mm} \times 5 \text{ mm}) + (102 \text{ mm} \times 3 \text{ mm})$
 $= 496 \text{ mm}^2 (0.000496 \text{ m}^2)$

Volume of reservoir
(1 lin m of crack) $= 1 \text{ m} \times 0.000496 \text{ m}^2$
 $= 0.000496 \text{ m}^3$

Gross Application
Rate (no waste) $= 1,070 \text{ kg/m}^3 \times 0.000496 \text{ m}^3$
 $= 0.53 \text{ kg/lin m of crack}$

Net Application
Rate (15% waste) $= 1.15 \times 0.53 \text{ kg/lin m}$
 $= 0.61 \text{ kg/lin m of crack}$

Placement Cost (both options)

Labor cost $= (10 \text{ lab} \times \$120/\text{lab}) + (1 \text{ sup} \times \$200/\text{sup})$
 $= \$1,400/\text{day}$

Equipment cost $= \$500/\text{day}$

Placement cost $= \$1,400/\text{day} + \$500/\text{day}$
 $= \$1,900/\text{day}$

Crack Treatment Cost-Effectiveness

	Option #1	Option #2
A. Cost of purchasing and shipping material.	\$ <u>1.43/kg</u>	\$ <u>1.90/kg</u>
B. Net application rate.	<u>0.62 kg/lin m</u>	<u>0.61 kg/lin m</u>
C. Placement cost (labor & equipment).	\$ <u>1,900/day</u>	\$ <u>1,900/day</u>
D. Production rate.	<u>762 lin m/day</u>	<u>915 lin m/day</u>
E. User delay cost.	\$ <u>2000/day</u>	\$ <u>2000/day</u>
F. Total installation cost.		
$F = (A \times B) + (C/D) + (E/D)$	$(1.43 \times 0.62) + (1900/762)$ $+ (2000/762)$	$(1.90 \times 0.61) + (1900/915)$ $+ (2000/915)$
	= \$ <u>6.00/lin m</u>	= \$ <u>5.42/lin m</u>
G. Interest rate.	<u>5.0 percent</u>	<u>5.0 percent</u>
H. Estimated service life (time to 50 percent failure).	<u>3 years</u>	<u>5 years</u>
I. Average annual cost.		
$I = \frac{F \times [G \times (1 + G)^H]}{(1 + G)^H - 1}$	$\frac{6.00 \times [0.05 \times (1 + 0.05)^3]}{[(1 + 0.05)^3 - 1]}$	$\frac{5.42 \times [0.05 \times (1 + 0.05)^5]}{[(1 + 0.05)^5 - 1]}$
	= \$ <u>2.20/lin m</u>	= \$ <u>1.25/lin m</u>

Figure C-1. Example cost-effectiveness analysis.

Based on the calculations made in figure C-1, option #2, with an average annual cost of \$1.25/lin m, is more cost-effective than option #1, with an average annual cost of \$2.20/lin m.

Appendix D

Inspection Checklists for Construction

This appendix contains inspection checklists for the various operational steps in a sealing or filling operation. These checklists were developed for use by inspectors or supervisors to maximize workmanship in the field, giving crack treatment the best chance possible to perform well.

D.1 Crack Cutting

- G 1. Cutting tips or blades are sufficiently sharp to minimize spalling and cracking.
- G 2. Operator is wearing appropriate safety attire.
- G 3. All guards and safety mechanisms on equipment are functioning properly.
- G 4. Cutting equipment follows cracks so that the percentage of missed cracks is minimized (less than 5 percent missed cracks).
- G 5. AC surface is not so cold as to inhibit cutting operations and cause excessive spalling or cracking.
- G 6. AC surface mixture is not so coarse as to inhibit cutting operations and cause excessive spalling or cracking.
- G 7. Cut reservoir dimensions are satisfactory and uniform, especially for bond-breaker application so that appropriate backer rod depth can be achieved.

D.2 Crack Cleaning and Drying

- G 1.** Oil and moisture filters on air compressor functioning properly. Periodic check for oil and moisture made by placing white towel over nozzle during operation.
- G 2.** Operator is wearing appropriate safety attire.
- G 3.** Dirt and debris are adequately blown from crack channel and surrounding pavement area to well off edge of roadway.
- G 4.** At least one pass on each side of crack channel is made with cleaning equipment.
- G 5.** When cleaning and drying with hot compressed air, intended bonding surfaces are darkened but not burned.
- G 6.** Cleaning operation is maintained just ahead of sealing or filling operation in order to retain crack cleanliness.
- G 7.** Hot airblasting operation is conducted immediately ahead of hot-applied sealant or filler installation so that the potential for moisture condensation is minimized and crack surface warmth is maximized (5 minutes or 50 m maximum).
- G 8.** Check periodically for crack cleanliness by running finger along crack sidewalls and examining for dirt, dust, or oxidized asphalt grit.
- G 9.** Check periodically for crack moisture visually and by feeling crack sidewalls.

- G 10. Consistently check cracks for loosened fragments, and remove by hand those that will come free.
- G 11. Blasting operations (sand or air) always proceeding away from and are directed away from passing traffic.
- G 12. Airblasting and hot airblasting nozzles are held no more than 50 mm away from crack channel during first pass.
- G 13. Sandblasting nozzle is directed against crack sidewalls and maintained 100 to 150 mm away.

D.3 Material Preparation and Installation

D.3.1 Backer Rod Installation

- G 1. Backer rod placed to specified depth.
- G 2. Wide crack segments filled with additional or larger backer rod.
- G 3. Backer rod sufficiently compressed in reservoir so that the weight of uncured sealant does not force it down into the reservoir.
- G 4. Surface of backer rod not damaged, twisted, or excessively stretched during installation.

D.3.2 Sealant or Filler Preparation and Installation

- G 1.** A double-boiler, agitator-type kettle with oil heat transfer is used for hot-applied, rubber-modified asphalt materials.
- G 2.** Kettle with full-sweep agitation and 50-mm recirculating pump used for fiberized asphalt applications.
- G 3.** Operator is wearing appropriate safety attire.
- G 4.** Melting vat kept at least one-third full of material to reduce chance of burning material or introducing air into pumping system.
- G 5.** Systematic check of material temperature in vat by both kettle temperature gauge and thermometer probe.
- G 6.** Recirculate material during idle periods.
- G 7.** Pump functions efficiently (no loss of power causing surges of material extrusion).
- G 8.** Crack channel filled with material from bottom up.
- G 9.** Crack channel filled with material to specified level in recessed configurations.
- G 10.** Sufficient amount of material is dispensed to form design configuration, but not so much as to oversupply squeegee.

- G 11. Material is reapplied to crack segments that initially received too little material or experienced settling of material.
- G 12. Material installation operations follow immediately behind cleaning and drying operation to retain crack cleanliness and, if hot airblasting, the potential for moisture condensation in the crack is minimized and crack warmth is maximized.
- G 13. No bubbling due to moisture in crack channel after installing hot-applied materials.
- G 14. Spilled material removed from the pavement surface.
- G 15. Melter vat and application equipment thoroughly cleaned of contaminant materials.

D.4 Material Finishing/Shaping

- G 1. Squeegee size and shape appropriate for planned material placement configuration.
- G 2. Rubber inserts on squeegee cut to desired dimension for creating overband (periodically checking for cut-out wear).
- G 3. Material buildup on squeegee being removed with propane torch.
- G 4. Squeegee operated immediately after material application or strike-off delayed to allow overly runny material to cool in order to prevent slumping of band.

- G 5. Band-aid squeegee consistently centered over crack.
- G 6. Hot-applied material is cooling sufficiently to prevent tracking given the type of traffic control setup and ambient conditions.
- G 7. Bond checked by peeling "cooled" hot-applied sealant from crack channel (check for moisture and dirt).
- G 8. No bubbling due to moisture in crack channel after installation of hot-applied materials.

D.5 Material Blotting

- G 1. Sufficient amount of sand applied to fully cover emulsion material.
- G 2. Toilet paper, dust, or powder applied to fully cover hot-applied rubber-modified asphalts.

Appendix E

Material and Equipment Safety Precautions

E.1 Materials

To protect their health and well-being, maintenance workers who handle the various treatment materials should review material safety data sheets (MSDS's). These sheets provide important information about health, fire, and reactivity hazards.

Some common-sense precautions for preventing harmful contact or ingestion of materials include wearing the following protective clothing and equipment:

- ! Long-sleeved shirts.
- ! Long pants.
- ! Gloves.
- ! Steel-toed boots.
- ! Eye protection.

E.2. Equipment

Safety precautions should also be taken for those operating the various pieces of equipment used in sealing or filling operations. In general, these include the following:

- ! Routers/Saws—Eye and hearing protection, protective clothing, steel-toed boots.
- ! Air Compressors—Eye and hearing protection, protective clothing.

- ! HCA/Heat Lances—Eye and hearing protection, fire-retardant clothing including boots and leggings that cover lower legs.
- ! Sandblasters—Air-fed protective helmet, air supply purifier, and protective clothing.
- ! Distributors and Asphalt Kettles—Eye protection, protective clothing.

Appendix F

Partial List of Material and Equipment Sources

This appendix includes a partial listing of crack treatment material and equipment manufacturers. Addresses and phone numbers are provided for major manufacturers who can provide the user with information regarding products, installation practices, and safety procedures.

This list is intended to serve as a starting point for the user pursuing information about materials and equipment. It is not an endorsement for the manufacturers included and is not intended to carry negative connotations for manufacturers not included.

F.1 Materials

F.1.1 Manufacturers of Cold-Applied Thermoplastic Bituminous Materials

Unique Paving
Materials Corporation
3993 East 93rd Street
Cleveland, OH 44105-4096
(800) 441-4881
www.upm.com

F.1.2 Manufacturers of Hot-Applied Thermoplastic Bituminous Materials

Koch Materials Company
4111 E. 37th Street North
P.O. Box 2338
Wichita, KS 67220
(316) 828-8399
(800) 654-9182
www.kochmaterials.com

Crafco Inc.
6975 W. Crafco Way
Chandler, AZ 85226
(602) 276-0406
(800) 528-8242
www.crafco.com

W.R. Meadows, Inc.
300 Industrial Drive
Box 338
Hampshire, IL 60140-0338
(847) 683-4500
(800) 342-5976
www.wrmeadows.com

Meggison Enterprises, Inc.
870 E. 50th Avenue
Denver, CO 80216
(800) 296-3439

F.1.3 Manufacturers of Self-Leveling Silicone

Dow Corning Corporation
P.O. Box 994
Midland, MI 48686-0994
(517) 496-4000
www.dowcorning.com

F.2 Equipment

F.2.1 Manufacturers of Cutting Equipment

Crafco Inc.
6975 W. Crafco Way
Chandler, AZ 85226
(602) 276-0406
(800) 528-8242
www.crafco.com

Cimline, Inc.
2601 Niagara Lane
Minneapolis, MN 55447
(800) 328-3874
www.cimline.com

Aeroil Products Co., Inc.
450 Sweeney Drive
Crossville, TN 38555
(615) 456-8655
(800) 526-0987
www.aeroil.com

Target Products Inc.
4320 Clary Blvd.
Kansas City, MO 64130
(816) 923-5040

F.2.2 Manufacturers of Heat Lances

Cimline, Inc.
2601 Niagara Lane
Minneapolis, MN 55447
(800) 328-3874
www.cimline.com

Brewpro, Inc.
P.O. Box 43130
Cincinnati, OH 45243
(513) 577-7200

F.2.3 Manufacturers of Asphalt Kettles

Crafco Inc.
6975 W. Crafco Way
Chandler, AZ 85226
(602) 276-0406
(800) 528-8242
www.crafco.com

Cimline, Inc.
2601 Niagara Lane
Minneapolis, MN 55447
(800) 328-3874
www.cimline.com

Bear Cat Manufacturing
3650 Sabin Brown Road
Wickenburg, AZ 85390
(602) 684-7851

Stepp Manufacturing Co.
12325 River Road
North Branch, MN 55056
(612) 674-4491
(800) 359-8167
www.steppmfg.com

F.2.4 Manufacturers of Silicone Pumps

Graco, Inc.
P.O. Box 1441
Minneapolis, MN 55440-1441
(612) 623-6000
(800) 367-4023
www.graco.com

Glossary

Abrasion—The wearing away of treatment material by tire friction or snowplow scraping.

Adhesiveness—The ability of a material to remain bonded to crack sidewalls and the pavement surface.

Band-Aid—An overband configuration where material is shaped/finished to desired dimensions.

Capped—An overband configuration where material is not shaped/finished. The material is allowed to level over crack channel by itself.

Cohesiveness—The ability of a material to resist internal rupture.

Cost-Effectiveness—The degree to which a treatment is both useful and economical.

Crack Channel—The crack cavity as defined by either original (uncut) crack or cut crack.

Crack Repair—Maintenance in which badly deteriorated cracks are repaired through patching operations.

Crack Reservoir—A uniform crack channel resulting from cutting operations. Generally rectangular in shape.

Crack Treatment—Maintenance in which cracks are directly treated through sealing or filling operations.

Cupping—A depression in the pavement profile along crack edges caused by damaged or weakened sub-layers.

Edge Deterioration—Secondary cracks and spalls that occur within a few millimeters along the edges of a primary crack.

Effectiveness—See *Treatment Effectiveness*.

Elasticity—The ability of a material to recover from deformation and resist intrusion of foreign materials.

Faulting—A difference in elevation between opposing sides of a crack caused by weak or moisture-sensitive foundation material.

Flexibility—The ability of a material to extend to accommodate crack movement.

Incompressible—Material, such as sand, stone, and dirt, that resists the compression of a closing crack channel.

Lipping—An upheaval in the pavement profile along crack edges. Lipping may be the result of bulging in underlying PCC base or the infiltration and buildup of material in the crack.

Longitudinal—Parallel to the centerline of the pavement or laydown direction (SHRP, 1993).

Non-working (cracks)—Cracks that experience relatively little horizontal or vertical movement as a result of temperature change or traffic loading. As a general rule, movement less than 3 mm.

Overband—A type of finish in which material is allowed to completely cover crack channel by extending onto pavement surface. Overbands consist of band-aid and capped configurations.

Secondary Crack—A crack extending parallel to or radially from a primary crack. A form of edge deterioration.

Serviceability—The ability, at time of observation, of a pavement to serve traffic that uses the facility (AASHTO, 1986).

Spall—A chipped segment of AC pavement occurring along a primary crack edge. A form of edge deterioration.

Thermoplastic (material)—A material that becomes soft when heated and hard when cooled.

Thermosetting (material)—A material that hardens permanently when heated.

Transverse—Perpendicular to the pavement centerline or direction of laydown (SHRP, 1993).

Treatment Effectiveness—The degree to which a treatment is performing its function.

Treatment Failure—The degree to which a treatment is not performing its function.

Working (cracks)—Cracks that experience considerable horizontal or vertical movement as a result of temperature change or traffic loading. In general, movement greater than or equal to 3 mm.

References

American Association of State Highway and Transportation Officials (AASHTO). 1986. *AASHTO Guide for Design of Pavement Structures*, Washington, D.C.

Cook, J.P., F.E. Weisgerber, and I.A. Minkarah. 1991. *Development of a Rational Approach to the Evaluation of Pavement Joint and Crack Sealing Materials*, Final Report, University of Cincinnati.

Evans, L.D., et al. 1993. *Innovative Materials Development and Testing. Volume 1: Project Overview (SHRP-H-352); Volume 2: Pothole Repair (SHRP-H-353); Volume 3: Treatment of Cracks in Asphalt Concrete-Surfaced Pavements (SHRP-H-354); Volume 4: Joint Seal Repair (SHRP-H-355); Volume 5: Partial-Depth Spall Repair (SHRP-H-356)*, Strategic Highway Research Program (SHRP), National Research Council, Washington, D.C.

Peterson, D.E. 1982. "Resealing Joints and Cracks in Rigid and Flexible Pavements," *NCHRP Synthesis of Highway Practice No. 98*, Transportation Research Board (TRB), National Research Council, Washington, D.C.

Smith, K.L., et al. 1991. *Innovative Materials and Equipment for Pavement Surface Repairs. Volume I: Summary of Material Performance and Experimental Plans (SHRP M/UFR-91-504); Volume II: Synthesis of Operational Deficiencies of Equipment Used for Pavement Surface Repairs (SHRP M/UFR-91-505)*, Strategic Highway Research Program (SHRP), National Research Council, Washington, D.C.

Smith, K.L. and A.R. Romine. 1999. *Long-Term Monitoring of SHRP H-106 Pavement Maintenance Materials Test Sites: AC Crack Treatment Experiment, Final Report*, Federal Highway Administration (FHWA), McLean, Virginia.

Strategic Highway Research Program (SHRP). 1993. *Distress Identification Manual for the Long-Term Pavement Performance Project*, Report No. SHRP-P-338, National Research Council, Washington, D.C.