

SECTION VIEW

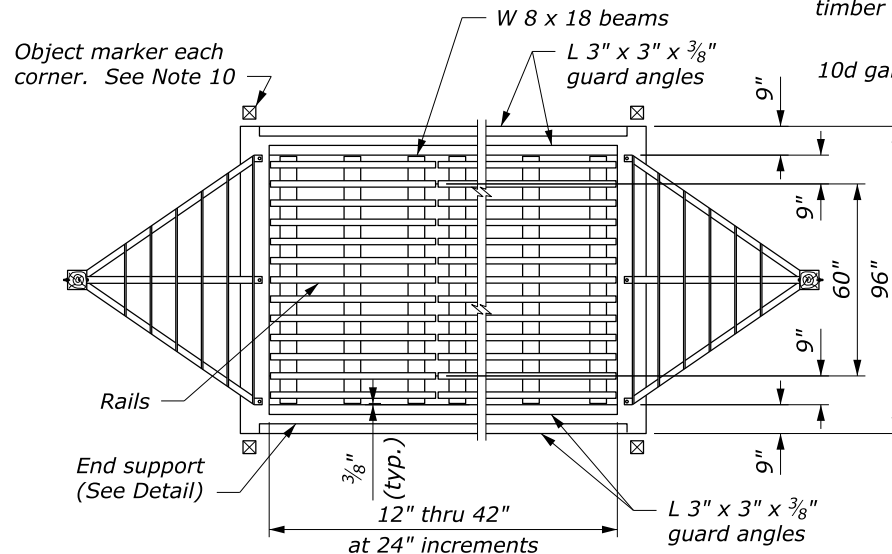

PLAN

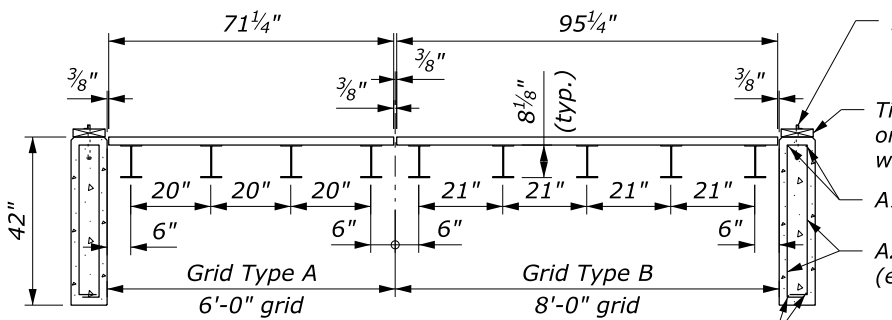

STANDARD GRID UNIT TYPES

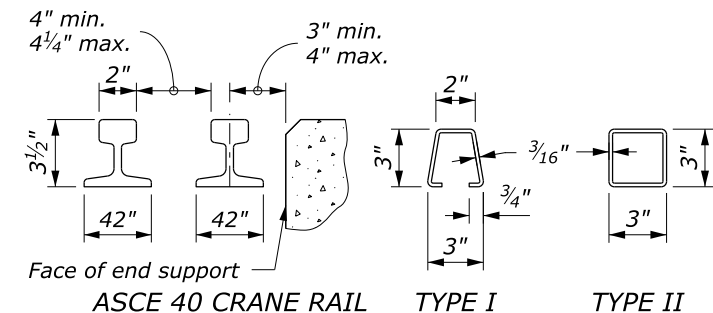

ACCEPTABLE ALTERNATE RAIL

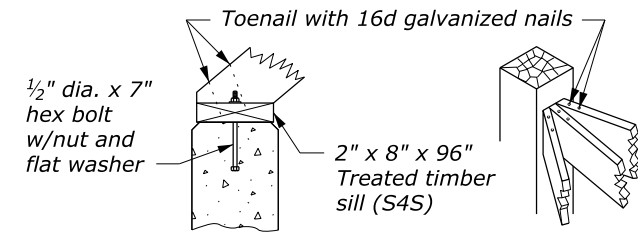

DETAIL A

DETAIL B

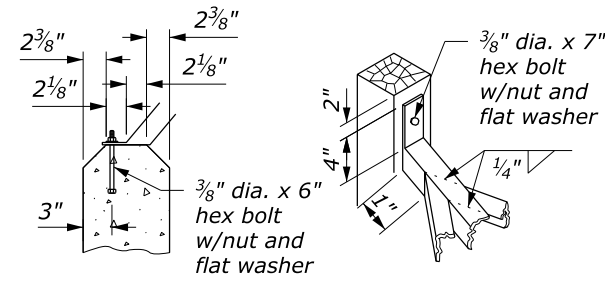

DETAIL C

DETAIL D

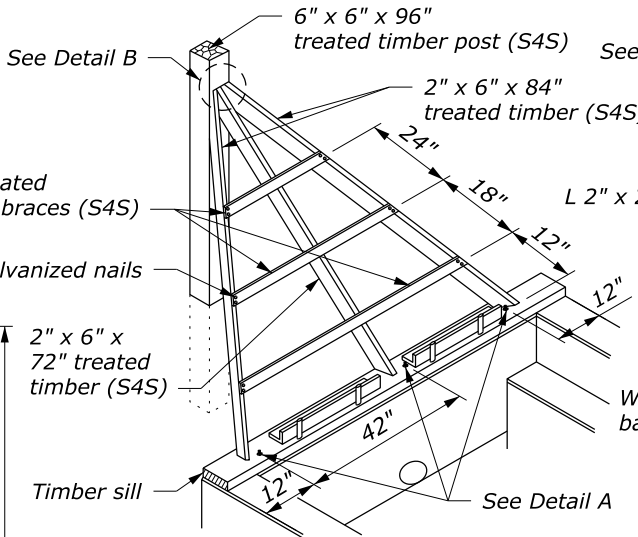

WOOD WING GUARD

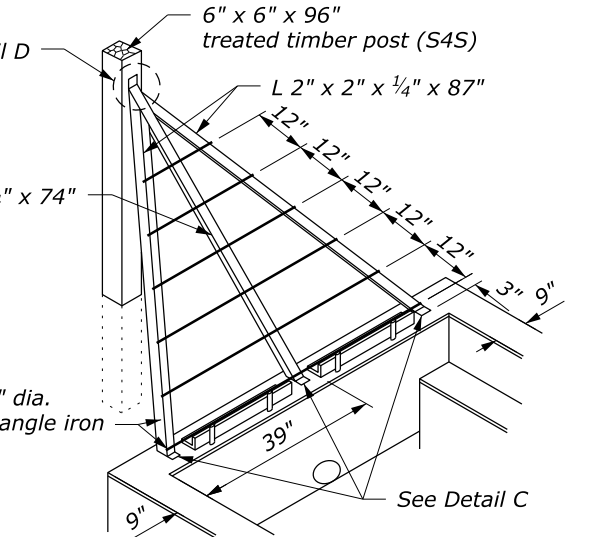

ANGLE IRON WING GUARD

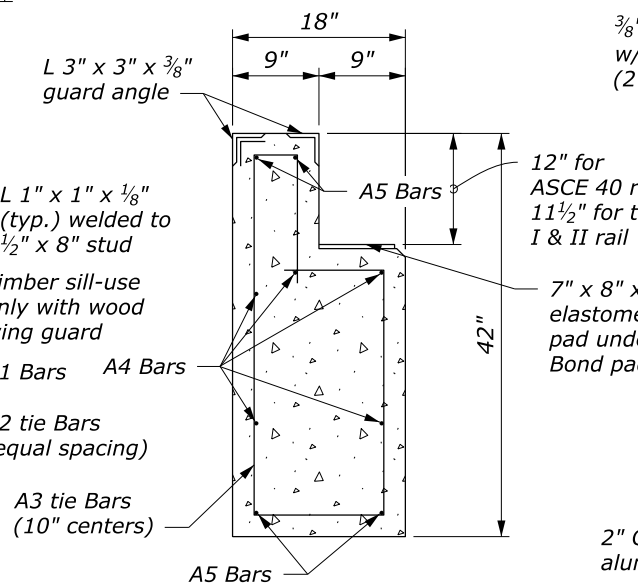

END SUPPORT DETAIL (#4 Reinforcing Bars)

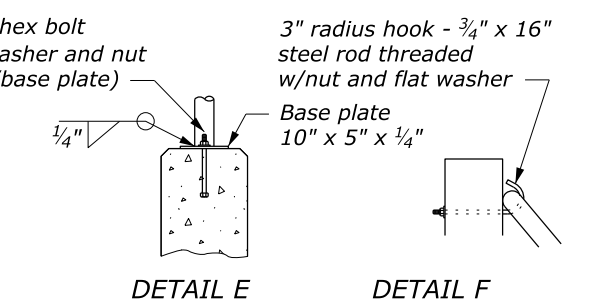

DETAIL E

DETAIL F

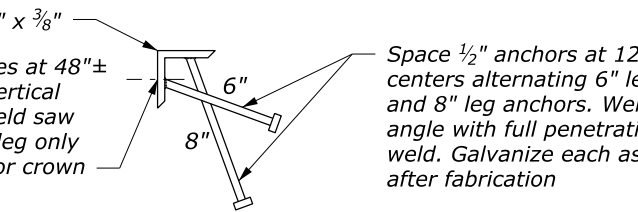

GUARD ANGLE DETAIL (4 required per cattle guard)

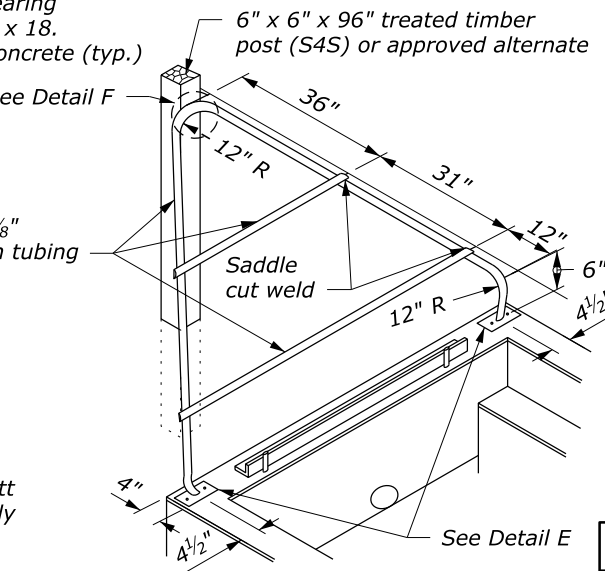

ALUMINUM TUBING WING GUARD

NO SCALE

NOTE:

- LOADING: AASHTO HS20.
- CONCRETE: Chamfer exposed edges 3/4" unless otherwise shown. Give all concrete surfaces a Class 1 finish.
- STRUCTURAL STEEL: Provide rails conforming to the requirements for ASCE 40 crane rail. Provide structural steel for alternate sections conforming to ASTM A 500, Grade B, Copper Steel or ASTM A 618, Grade 2. If the steel does not contain a minimum of 0.2 percent copper, galvanize the alternate sections. All other structural steel conforms to AASHTO ASTM A36 and is painted.
- Provide 2" minimum concrete cover to the face of any bar unless otherwise shown. All bars are #4.
- All welds are continuous 1/4" fillet shop welds. Weld rail or alternate sections on both sides to the W 8 x 18 beams at each intersection. Weld according to Section 555.
- Use aluminum alloy 6061-T6 or 6063-T6 for aluminum tubing.
- Provide timber conforming to AASHTO M 168. Treat timber with chromated copper arsenate according to AASHTO M 133.
- Galvanize all hardware according to AASHTO M 111.
- Construct the cattle guard to conform with the finished roadway grade and template.
- Place one object marker at each corner of the cattle guard as shown. Mount object markers on 4" x 4" x 6'-0" posts with the reflector located 42" above the elevation of the lateral support concrete.
- Install drain pipe as shown where required. Include drain pipe with cattle guard unless otherwise shown.
- Unless otherwise shown in the special contract requirements, shop apply coating according to Section 563. Use Federal Standard 595B, Gray, 36231 for the top coat. Repair any damage to the coating installation.
- Install channels and wood blocking on cattle guards wider than 16 feet to maintain grate spacing as shown on Standard 619-2.
- See Standard 619-3 for optional precast foundation details.

U.S. DEPARTMENT OF TRANSPORTATION, FHWA
OFFICE OF FEDERAL LANDS HIGHWAY

FLH STANDARD
619-1

CATTLE GUARD

SPECIFICATION
FP-24

APPROVED FOR USE
1/2024

CATTLE GUARD

REINFORCING STEEL, CONCRETE, STRUCTURAL STEEL, AND GRID UNIT TABLE OF QUANTITIES

DESCRIPTION	NOMINAL CATTLE GUARD WIDTH																												REMARKS								
	12'		14'		16'		18'		20'		22'		24'		26'		28'		30'		32'		34'		36'		38'			40'		42'					
	QTY	LENGTH	QTY	LENGTH	QTY	LENGTH	QTY	LENGTH	QTY	LENGTH	QTY	LENGTH	QTY	LENGTH	QTY	LENGTH	QTY	LENGTH	QTY	LENGTH	QTY	LENGTH	QTY	LENGTH	QTY	LENGTH	QTY	LENGTH		QTY	LENGTH	QTY	LENGTH				
#4 Reinforcing bars, A1	8	92"	8	92"	8	92"	8	92"	8	92"	8	92"	8	92"	8	92"	8	92"	8	92"	8	92"	8	92"	8	92"	8	92"	8	92"	8	92"	8	92"			
#4 Reinforcing bars, A2	20	86"	20	86"	20	86"	20	86"	20	86"	20	86"	20	86"	20	86"	20	86"	20	86"	20	86"	20	86"	20	86"	20	86"	20	86"	20	86"	20	86"	20	86"	See Bar Bending Detail
#4 Reinforcing bars, A3	32	108"	36	108"	40	108"	46	108"	50	108"	54	108"	60	108"	64	108"	70	108"	74	108"	80	108"	84	107"	90	108"	94	108"	98	108"	102	108"	108"	See Bar Bending Detail			
#4 Reinforcing bars, A4	10	156"	10	180"	10	204"	10	228"	10	252"	10	276"	10	300"	10	324"	10	348"	10	372"	100	396"	10	420"	10	444"	10	468"	10	492"	10	516"					
#4 Reinforcing bars, A5	8	140"	8	164"	8	188"	8	212"	8	236"	8	260"	8	284"	8	308"	8	332"	8	356"	8	380"	8	404"	8	428"	8	452"	8	476"	8	500"					
Grid unit A (6 ft)	2		1				3		2		1				3		2		5				3		6		1				7		See Grid Unit List of Materials				
Grid unit B (8 ft)			1		2				1		2		3		1		2				4		2				4		5				See Grid Unit List of Materials				
Concrete lateral supports, yd3	1.56		1.56		1.56		1.56		1.56		1.56		1.56		1.56		1.56		1.56		1.56		1.56		1.56		1.56		1.56		1.56						
Concrete end supports, yd3	4.03		4.70		5.37		6.04		6.71		7.38		8.05		8.73		9.40		10.07		10.74		11.41		12.08		12.75		13.42		14.10						
Total concrete, yd3	5.59		6.26		6.93		7.60		8.27		8.94		9.61		10.29		10.96		11.63		12.30		12.97		13.64		14.31		14.98		15.66						
W 8 x 18 beams	936		1053		1170		1404		1521		1638		1755		1989		2106		2340		2340		2574		2808		2808		2925		3276		Beams 18 lb/ft				
Rail, ASCE 40	2052		2398		2744		3078		3424		3770		4116		4450		4796		5130		5488		5822		6156		6514		6860		7182		13.30 lb/ft				
Rail, Type I	806		942		1078		1209		1345		1481		1617		1748		1884		2015		2156		2287		2418		2559		2695		2821		Approx. 5.22 lb/ft				
Rail, Type II	1060		1238		1416		1590		1768		1946		2124		2298		2476		2650		2832		3006		3180		3362		3540		3710		6.86 lb/ft				
Reinforcing steel, lb	478		526		574		634		683		731		791		839		899		947		1007		1055		1115		1164		1212		1260		0.668 lb/ft				

* Structural steel weights do not include hardware or guard angle.

CATTLE GUARD WING

LIST OF MATERIALS PER WING (TWO REQUIRED PER INSTALLATION)

PART DESCRIPTION	WOOD WING	ANGLE IRON WING	ALUMINUM TUBING WING
Outside diagonal supports	Two 2" x 6" x 84" treated S4S	Two 2" x 2" x 1/4" x 87" galvanized steel angle	One 2" OD x 1/8" x 165" aluminum tubing
Middle support	One 2" x 6" x 72" treated S4S	One 2" x 2" x 1/4" x 73" galvanized steel angle	
Horizontal brace No. 1	One 2" x 6" x 66" treated S4S	One 1/2" x 78" galvanized steel bar	One 2" OD x 1/8" x 72" aluminum tubing
No. 2	One 2" x 6" x 48" treated S4S	One 1/2" x 66" galvanized steel bar	One 2" OD x 1/8" x 30" aluminum tubing
No. 3	One 2" x 6" x 18" treated S4S	One 1/2" x 54" galvanized steel bar	None
No. 4	None	One 1/2" x 39" galvanized steel bar	None
No. 5	None	One 1/2" x 24" galvanized steel bar	None
No. 6	None	One 1/2" x 9" galvanized steel bar	None
Post	6" x 6" x 96" treated S4S	One 6" x 6" x 84" treated S4S or approved alternate	One 6" x 6" x 96" treated S4S or approved alternate
Top anchor assembly	Toenail diagonal supports to the post with 16d galvanized nails as required	3/8" dia. x 6" galvanized hex bolt w/nut and flat washer	3/4" dia. x 16" galvanized steel rod threaded on one end w/nut and washers & 3" radius hook in other end
Bottom anchor assembly	2" x 8" x 96" treated S4S sill attached to concrete w/ 3 each 1/2" dia. x 7" hex bolts w/nuts & washers embedded in concrete. Toenail diagonal supports to wooden sill w/16d galvanized nails	3 each 3/8" dia. x 6" galvanized hex bolts embedded in concrete. Attach steel L iron to bolt w/flat washer and nut	2 each 1/4" x 5" x 10" flat irons welded to 4" tubing. 4 each 3/4" dia. x 6" galvanized hex bolts embedded in concrete. Attach the flat iron plates to the bolts with washer & nuts

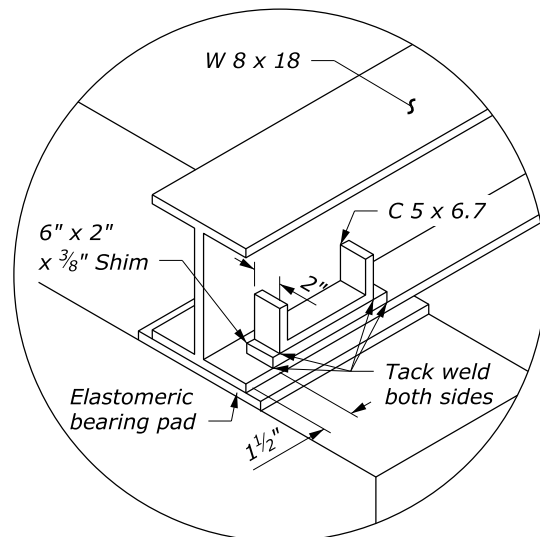

DETAIL A

GRID UNIT LIST OF MATERIALS
GRID UNIT TYPE A
4 each W 8 x 18 x 77" long 13 each ASCE 40 crane rail (with minimum spacing), or II tubular cross bar sections, (with minimum spacing), type I or type II, 71 1/4"
GRID UNIT TYPE B
5 each W 8 x 18 x 77" long 13 each ASCE 40 crane rail (with minimum spacing), or II tubular cross bar sections, (with minimum spacing), type I or type II, 95 1/4"

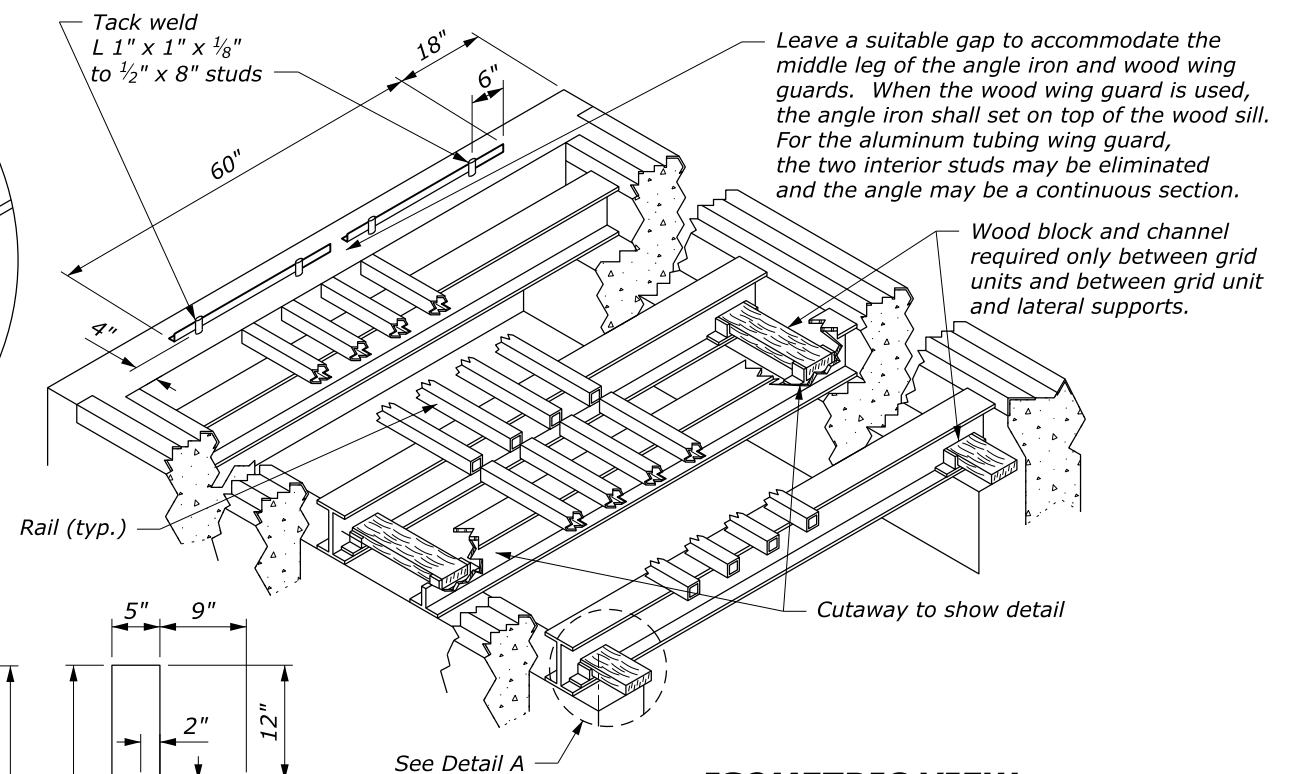

ISOMETRIC VIEW

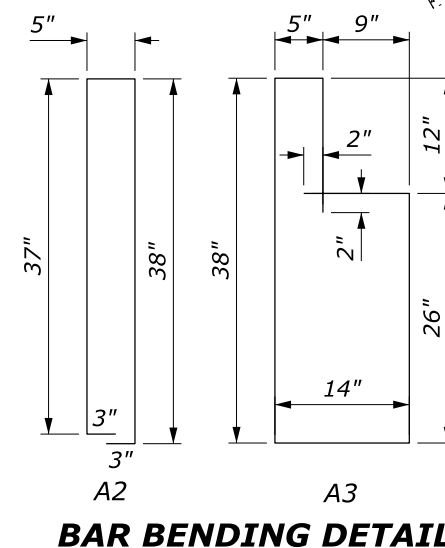

BAR BENDING DETAIL

NO SCALE

U.S. DEPARTMENT OF TRANSPORTATION, FHWA OFFICE OF FEDERAL LANDS HIGHWAY	FLH STANDARD 619-2
CATTLE GUARD	SPECIFICATION FP-24, FP-14
	APPROVED FOR USE 1/2024

CATTLE GUARD

REINFORCING STEEL, CONCRETE, STRUCTURAL STEEL, AND GRID UNIT TABLE OF QUANTITIES

DESCRIPTION	NOMINAL CATTLE GUARD WIDTH																												REMARKS								
	3.6 m		4.2 m		4.8 m		5.4 m		6.0 m		6.6 m		7.2 m		7.8 m		8.4 m		9.0 m		9.6 m		10.2 m		10.8 m		11.4 m			12.0 m		12.6 m					
	QTY	LENGTH	QTY	LENGTH	QTY	LENGTH	QTY	LENGTH	QTY	LENGTH	QTY	LENGTH	QTY	LENGTH	QTY	LENGTH	QTY	LENGTH	QTY	LENGTH	QTY	LENGTH	QTY	LENGTH	QTY	LENGTH	QTY	LENGTH		QTY	LENGTH	QTY	LENGTH				
#13 Reinforcing bars, A1	8	2300	8	2300	8	2300	8	2300	8	2300	8	2300	8	2300	8	2300	8	2300	8	2300	8	2300	8	2300	8	2300	8	2300	8	2300	8	2300	8	2300			
#13 Reinforcing bars, A2	20	2150	20	2150	20	2150	20	2150	20	2150	20	2150	20	2150	20	2150	20	2150	20	2150	20	2150	20	2150	20	2150	20	2150	20	2150	20	2150	20	2150	20	2150	See Bar Bending Detail
#13 Reinforcing bars, A3	32	2700	36	2700	40	2700	46	2700	50	2700	54	2700	60	2700	64	2700	70	2700	74	2700	80	2700	84	2700	90	2700	94	2700	98	2700	102	2700	102	2700	102	2700	See Bar Bending Detail
#13 Reinforcing bars, A4	10	3900	10	4500	10	5100	10	5700	10	6300	10	6900	10	7500	10	8100	10	8700	10	9300	100	9900	10	10500	10	11100	10	11700	10	12300	10	12900					
#13 Reinforcing bars, A5	8	3500	8	4100	8	4700	8	5300	8	5900	8	6500	8	7100	8	7700	8	8300	8	8900	8	9500	8	10100	8	10700	8	11300	8	11900	8	12500					
Grid unit A (1.8 m)	2		1				3		2		1				3		2				5				3		6		1				7		See Grid Unit List of Materials		
Grid unit B (2.4 m)			1		2				1		2				3		1		2				4		2				4		5				See Grid Unit List of Materials		
Concrete lateral supports, m3	1.19		1.19		1.19		1.19		1.19		1.19		1.19		1.19		1.19		1.19		1.19		1.19		1.19		1.19		1.19		1.15						
Concrete end supports, m3	3.07		3.59		4.11		4.62		5.12		5.66		6.16		6.67		7.19		7.71		8.21		8.73		9.24		9.76		10.26		10.78						
Total concrete, m3	4.26		4.78		5.30		5.81		6.31		6.85		7.35		7.86		8.38		8.90		9.40		9.92		10.43		10.95		11.45		11.93						
W 200 x 27 beams	416		468		540		624		676		728		780		884		936		1040		1040		1144		1248		1248		1300		1456		Beams 27 kg/m				
Rail, ASCE 40	920		1073		1226		1380		1533		1686		1839		1993		2146		2300		2452		2606		2760		2912		3065		3220		19.82 kg/m				
Rail, Type I	360		420		480		540		600		660		720		780		840		900		960		1020		1080		1140		1200		1260		Approx. 7.77 kg/m				
Rail, Type II	472		552		632		708		788		868		945		1024		1104		1180		1264		1340		1416		1500		1580		1652		10.2 kg/m				
Reinforcing steel, kg	101.0		109.5		118.0		126.5		135.0		143.5		152.0		160.5		169.0		177.5		186.0		194.5		203.0		211.5		220.0		493		0.994 kg/m				

* Structural steel weights do not include hardware or guard angle.

CATTLE GUARD WING

LIST OF MATERIALS PER WING (TWO REQUIRED PER INSTALLATION)

PART DESCRIPTION	WOOD WING	ANGLE IRON WING	ALUMINUM TUBING WING
Outside diagonal supports	Two 50 x 150 x 2100 mm treated S4S	Two 51 x 51 x 6.4 x 2210 mm galvanized steel angle	One 50 mm OD x 3.17 x 4200 mm aluminum tubing
Middle support	One 50 x 150 x 1800 mm treated S4S	One 51 x 51 x 6.4 x 1850 mm galvanized steel angle	
Horizontal brace No. 1	One 50 x 150 x 1675 mm treated S4S	One 12 x 1980 mm galvanized steel bar	One 50 mm OD x 3.17 x 1830 mm aluminum tubing
No. 2	One 50 x 150 x 1220 mm treated S4S	One 12 x 1675 mm galvanized steel bar	One 50 mm OD x 3.17 x 760 mm aluminum tubing
No. 3	One 50 x 150 x 455 mm treated S4S	One 12 x 1370 mm galvanized steel bar	None
No. 4	None	One 12 x 990 mm galvanized steel bar	None
No. 5	None	One 12 x 610 mm galvanized steel bar	None
No. 6	None	One 12 x 225 mm galvanized steel bar	None
Post	150 x 150 x 2400 mm treated S4S	One 150 x 150 x 2100 mm treated S4S or approved alternate	One 150 x 150 x 2400 mm treated S4S or approved alternate
Top anchor assembly	Toenail diagonal supports to the post with 16d galvanized nails as required	M10 x 150 mm galvanized hex bolt w/nut and flat washer	M20 x 400 mm galvanized steel rod threaded on one end w/nut and washers & 75 mm radius hook in other end
Bottom anchor assembly	50 x 200 x 2400 mm treated S4S sill attached to concrete w/ 3 each M12 x 175 mm hex bolts w/nuts & washers embedded in concrete. Toenail diagonal supports to wooden sill w/16d galvanized nails	3 each M10 x 150 mm galvanized hex bolts embedded in concrete. Attach steel L iron to bolt w/flat washer and nut	2 each 6.4 x 125 x 250 mm flat irons welded to 100 mm tubing. 4 each M10 x 150 mm galvanized hex bolts embedded in concrete. Attach the flat iron plates to the bolts with washer & nuts

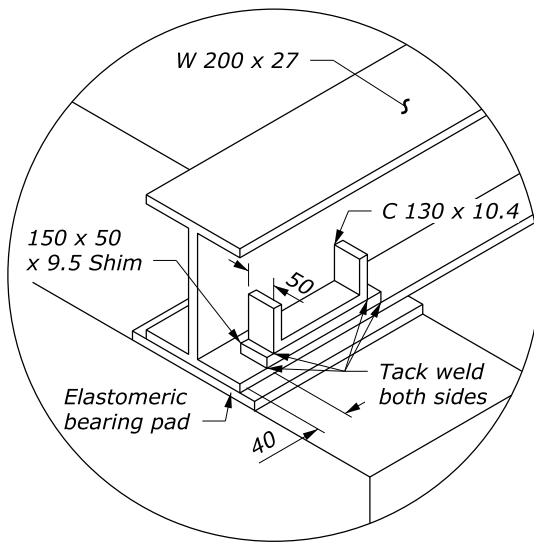

DETAIL A

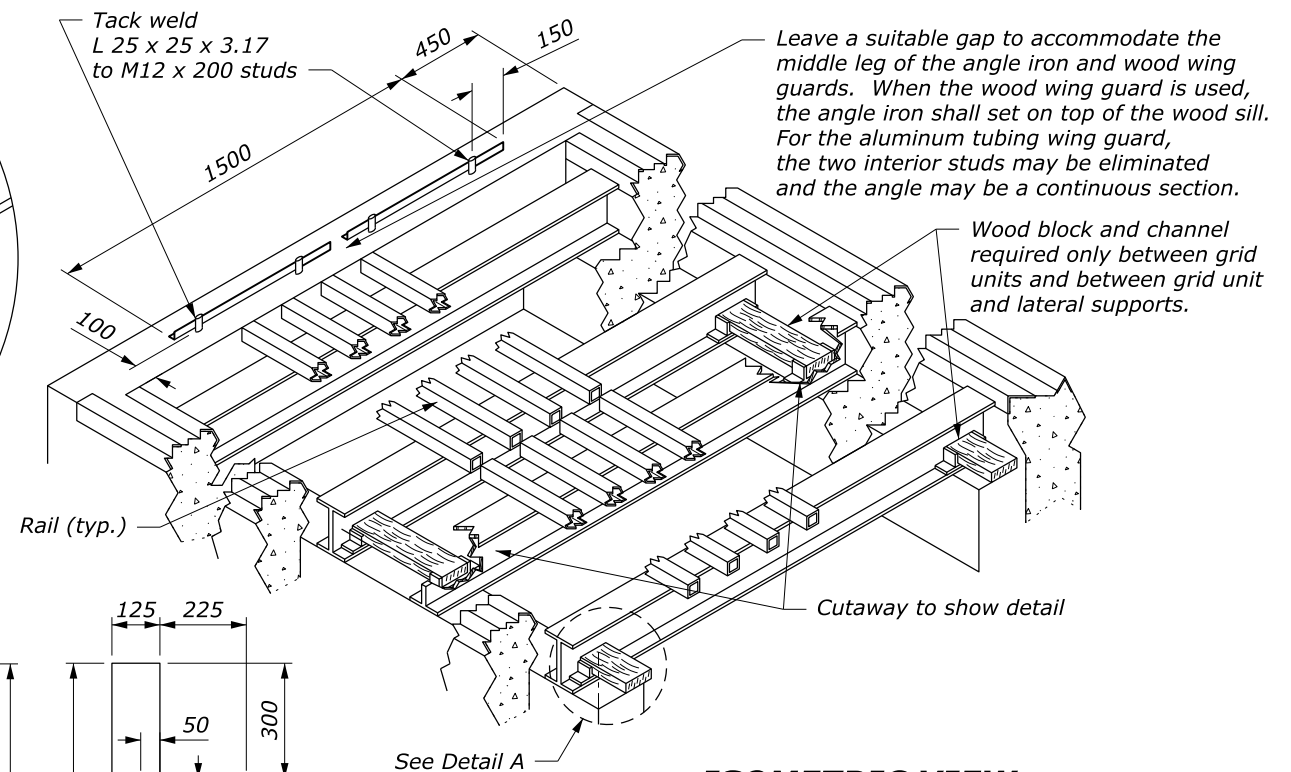

ISOMETRIC VIEW

GRID UNIT LIST OF MATERIALS
GRID UNIT TYPE A
4 each W 200 x 27 x 1925 mm long 13 each ASCE 40 crane rail (with minimum spacing), or II tubular cross bar sections, (with minimum spacing), type I or type II, 1780 mm
GRID UNIT TYPE B
5 each W 200 x 27 x 1925 mm long 13 each ASCE 40 crane rail (with minimum spacing), or II tubular cross bar sections, (with minimum spacing), type I or type II, 2380 mm

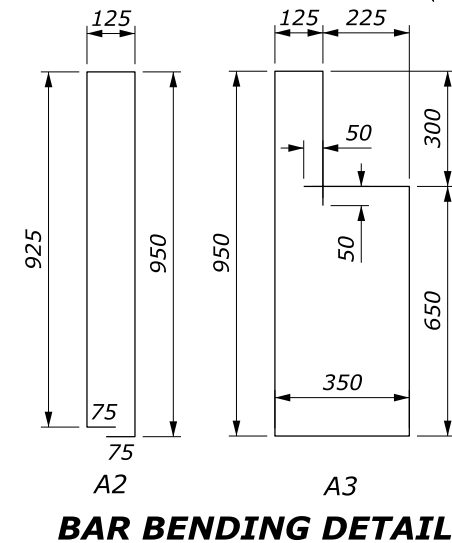

BAR BENDING DETAIL

NO SCALE

This drawing contains **Metric** units of measure. Dimensions without units are millimeters.

U.S. DEPARTMENT OF TRANSPORTATION, FHWA OFFICE OF FEDERAL LANDS HIGHWAY	FLH STANDARD M619-2
CATTLE GUARD	SPECIFICATION FP-24, FP-14
	APPROVED FOR USE 1/2024

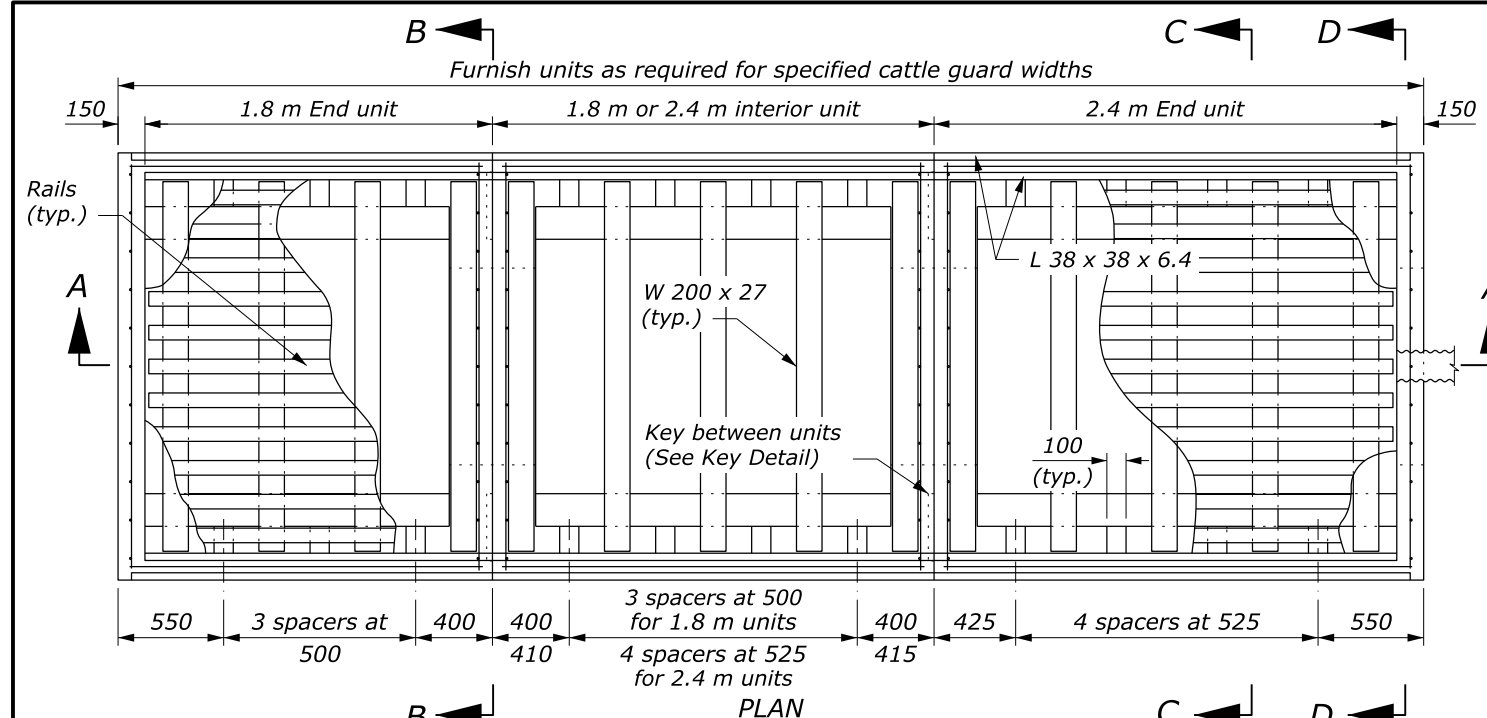

PLAN

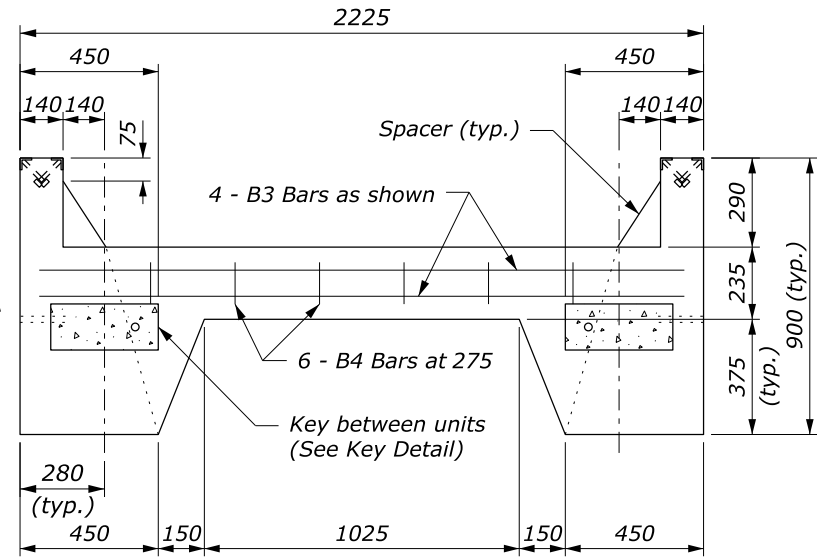

SECTION B-B

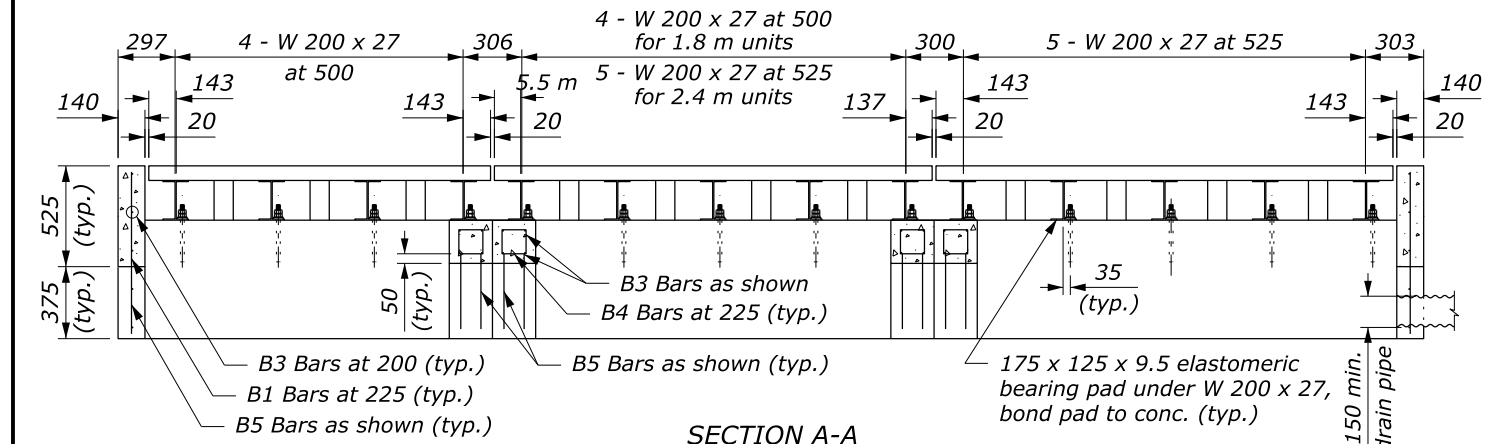

SECTION A-A

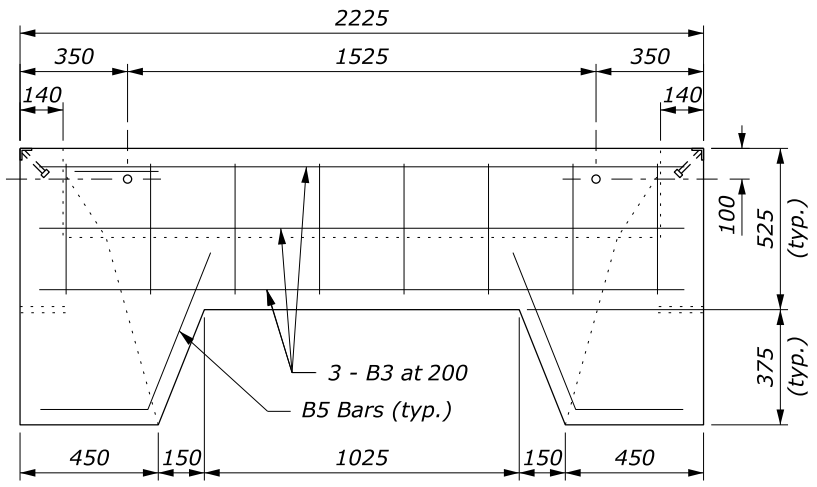

SECTION D-D

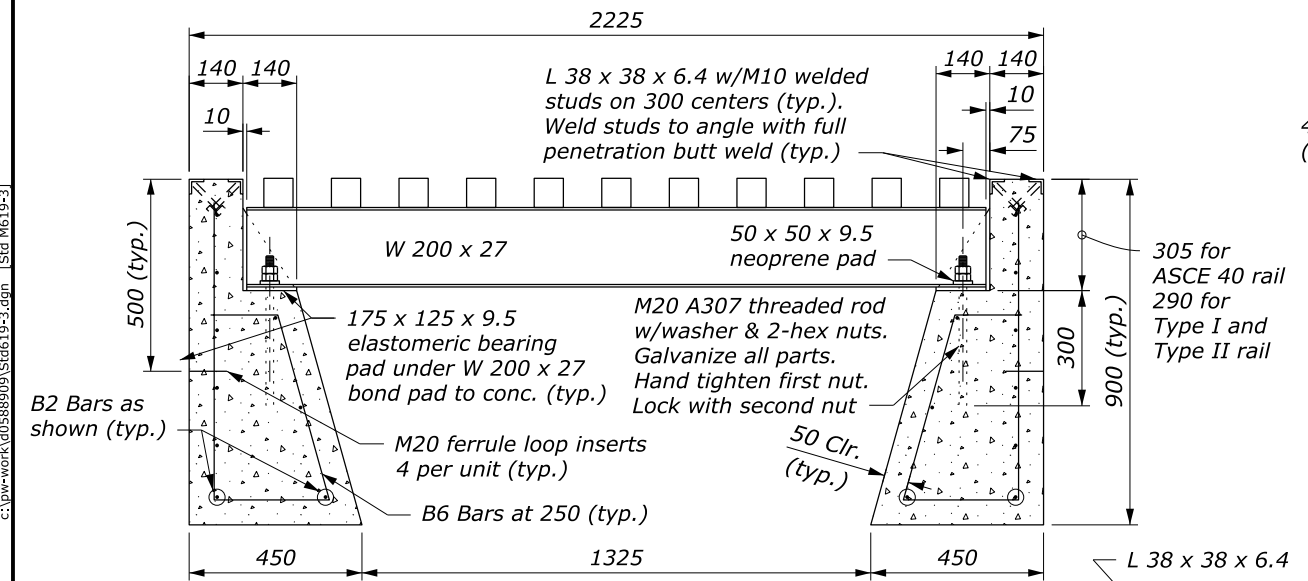

SECTION C-C



GUARD ANGLE DETAIL

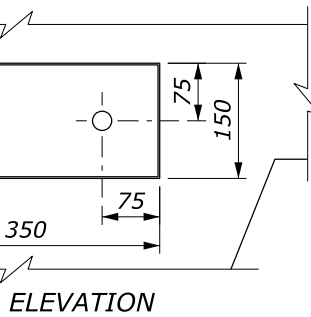
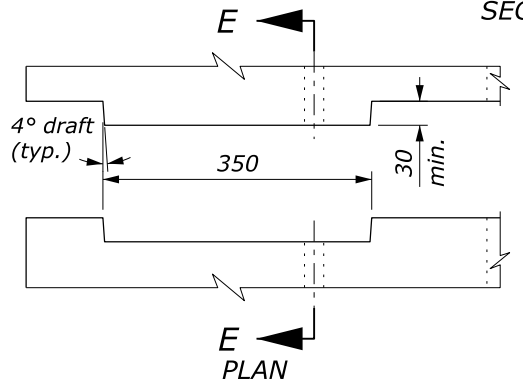

ELEVATION

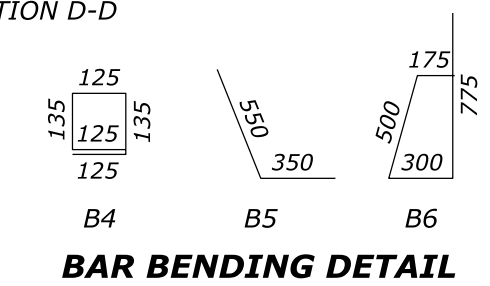

BAR BENDING DETAIL

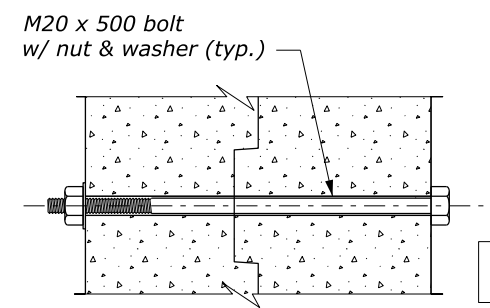

SECTION E-E

KEY DETAIL

NO SCALE

NOTE:

1. See Standard M619-1 for reinforcing steel size and grade.
2. See Standard M619-1 and 2 for cattle guard wing details. Fabricate end units to accommodate selected cattle guard wing.
3. Minimum soil bearing 19,500 kg/m². Place units in fine aggregate bed 75 mm thick over hand leveled soil compacted to not less than 95% density.
4. Chamfer exposed concrete edges 20 mm unless otherwise shown. Give all concrete surfaces a Class 1 finish.
5. Approved alternate designs may be used.

PRECAST CATTLE GUARD					
REINFORCING STEEL AND CONCRETE					
UNIT	No. of BARS	BAR MARK	LENGTH	MASS kg	CONCRETE m ³
1.8 m END	7	B3	2100	14.6	1.40
	10	B2	1850	18.4	
	8	B1	425	3.4	
	6	B4	650	3.9	
	18	B6	1750	31.3	
1.8 m INTERIOR	6	B5	900	5.4	1.41
	8	B3	2100	16.7	
	10	B2	1650	16.4	
	12	B4	650	7.8	
	18	B6	1750	31.3	
2.4 m INTERIOR	8	B5	900	7.2	1.73
	8	B3	2100	16.7	
	10	B2	2250	22.4	
	12	B4	650	7.8	
	20	B6	1750	34.8	
2.4 m END	8	B5	900	7.2	1.72
	7	B3	2100	14.6	
	10	B2	2450	24.4	
	8	B1	425	3.4	
	6	B4	650	3.9	
	20	B6	1750	34.8	
	6	B5	900	5.4	

This drawing contains **Metric** units of measure. Dimensions without units are millimeters.

U.S. DEPARTMENT OF TRANSPORTATION, FHWA
OFFICE OF FEDERAL LANDS HIGHWAY

**CATTLE GUARD
PRECAST FOUNDATION**

FLH STANDARD
M619-3
SPECIFICATION
FP-24, FP-14
APPROVED FOR USE
1/2024