

POST AND BLOCKOUT DETAIL

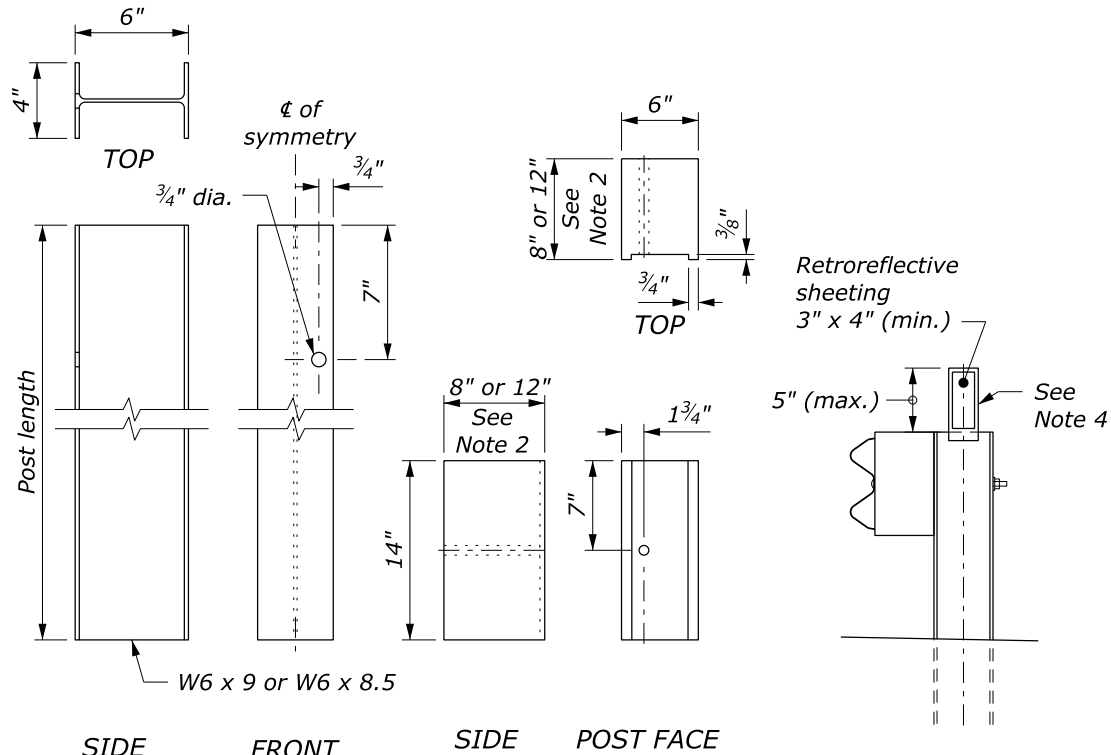

STRUCTURAL SHAPE POST **BLOCKOUT** **FLEXIBLE DELINEATOR GUARDRAIL MOUNT**

NOTE:

1. When encountering impenetrable material, one post may be omitted in locations where the typical guardrail cross section includes 2-feet (min.) between the back of the guardrail post and the hinge point. For all other locations, see Section 617 and Standard 617-13 or 617-37.
2. Size of blockout shown elsewhere in the plans. Blockout may be wood, plastic, or composite material. Use consistent material throughout the length of guardrail run.
3. Dimensional tolerances not shown or implied are intended to be those consistent with the proper functioning of the part, including its appearance, and accepted manufacturing practices.
4. Install a flexible hinged delineator every fourth post. Fasten delineator to the web of the steel post using either an adhesive or mechanical means according to the manufacturer's recommendations.

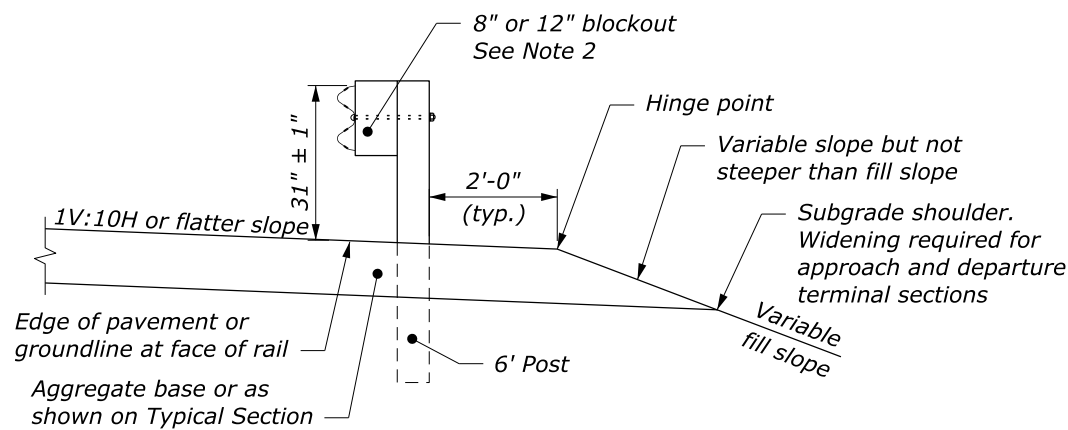

TYPICAL GUARDRAIL CROSS SECTION 6' POST, 8" OR 12" BLOCKOUT

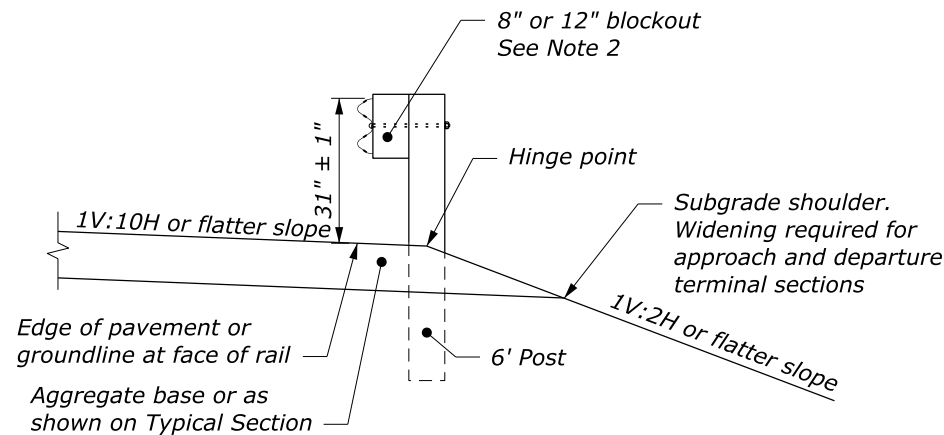

TYPICAL GUARDRAIL CROSS SECTION 6' POST CENTERED ON HINGE, 8" OR 12" BLOCKOUT

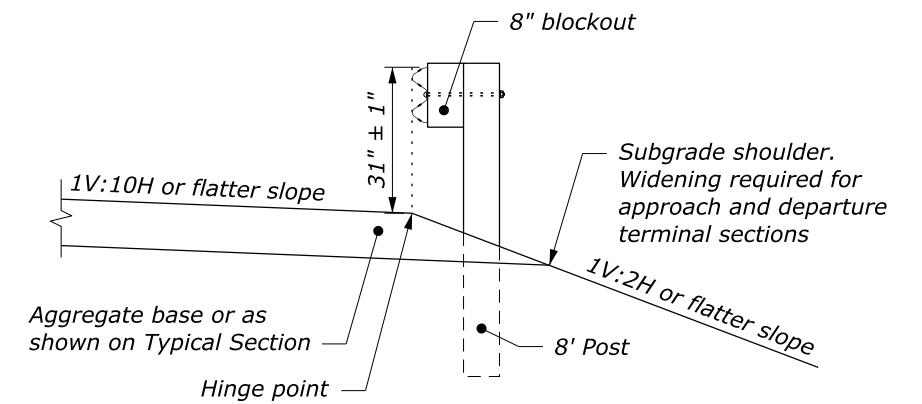

TYPICAL GUARDRAIL CROSS SECTION 8' POST ON SLOPE, 8" BLOCKOUT

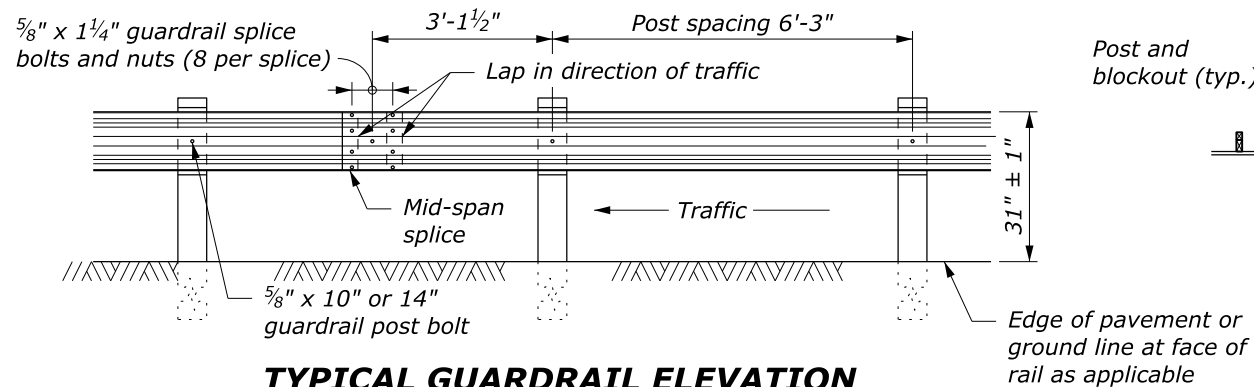

TYPICAL GUARDRAIL ELEVATION

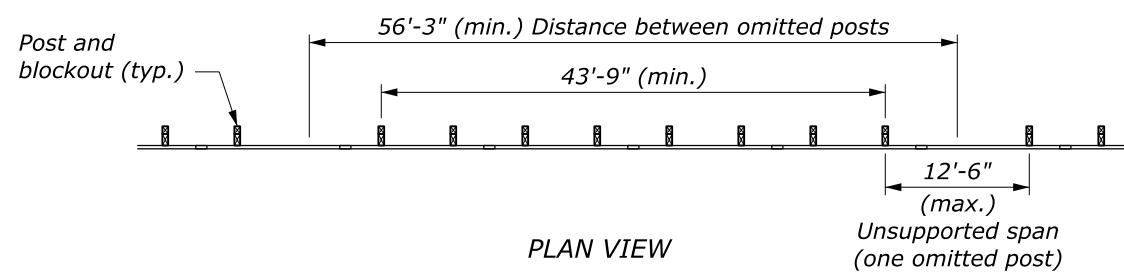

PLAN VIEW OMITTED POST DETAIL
See Note 1

NO SCALE

U.S. DEPARTMENT OF TRANSPORTATION, FHWA OFFICE OF FEDERAL LANDS HIGHWAY	FLH STANDARD 617-32
MGS W-BEAM GUARDRAIL STEEL POSTS	SPECIFICATION FP-14
	APPROVED FOR USE 2/2024

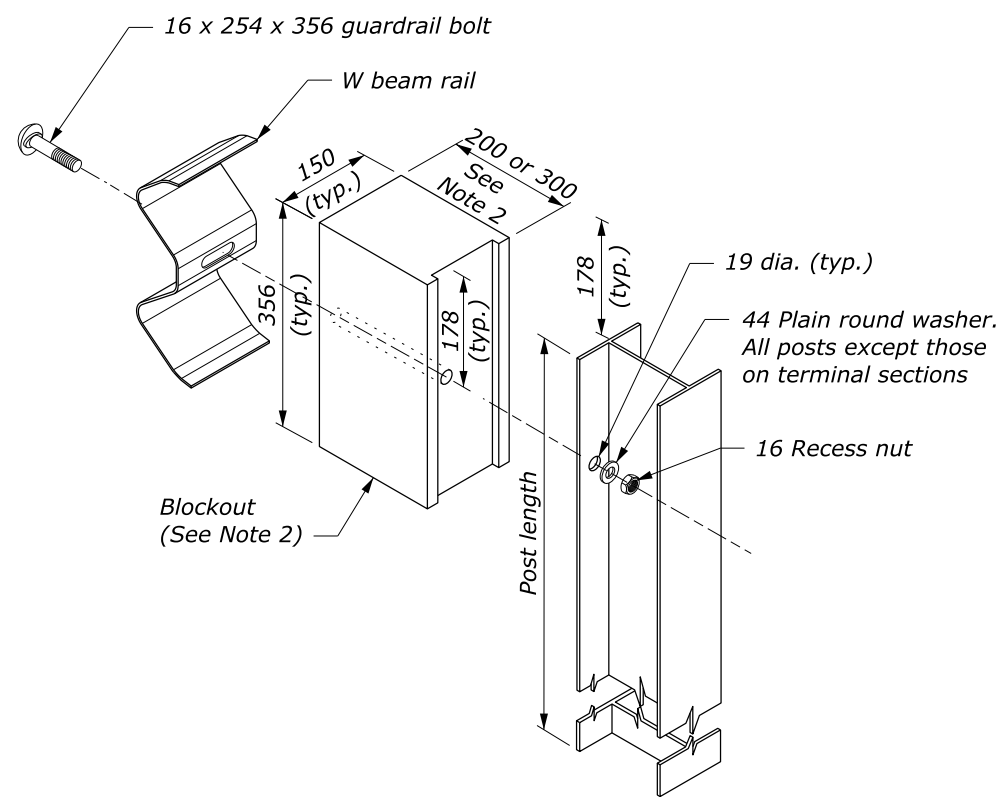

POST AND BLOCKOUT DETAIL

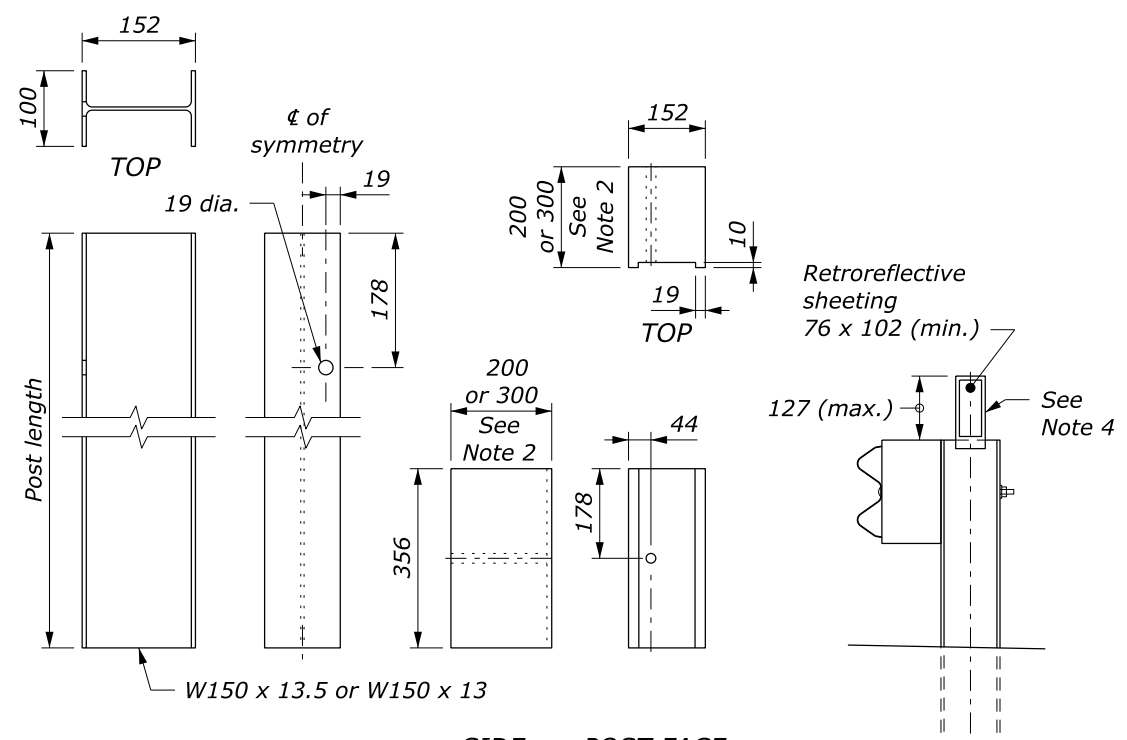

STRUCTURAL SHAPE POST BLOCKOUT FLEXIBLE DELINEATOR GUARDRAIL MOUNT

- NOTE:**
1. When encountering impenetrable material, one post may be omitted in locations where the typical guardrail cross section includes 609 mm (min.) between the back of the guardrail post and the hinge point. For all other locations, see Section 617 and Standard M617-13 or M617-37.
 2. Size of blockout shown elsewhere in the plans. Blockout may be wood, plastic, or composite material. Use consistent material throughout the length of guardrail run.
 3. Dimensional tolerances not shown or implied are intended to be those consistent with the proper functioning of the part, including its appearance, and accepted manufacturing practices.
 4. Install a flexible hinged delineator every fourth post. Fasten delineator to the web of the steel post using either an adhesive or mechanical means according to the manufacturer's recommendations.

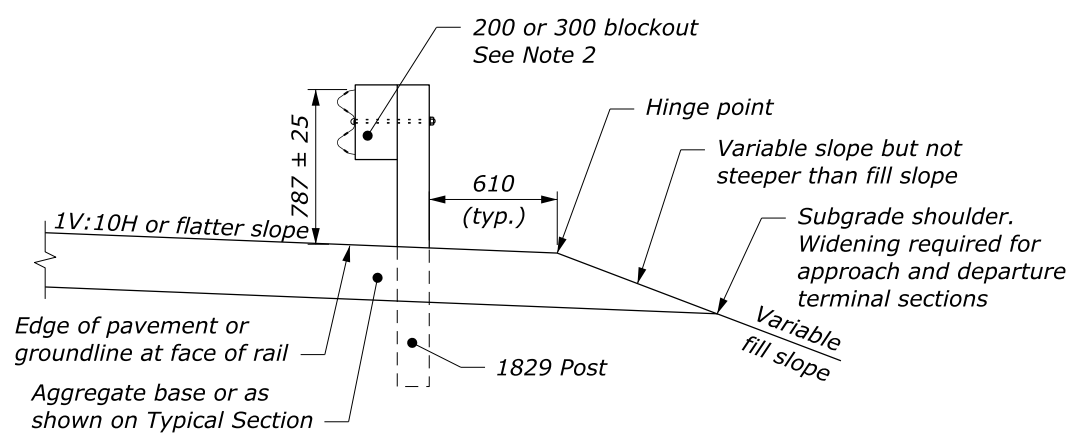

TYPICAL GUARDRAIL CROSS SECTION 1829 POST, 200 OR 300 BLOCKOUT

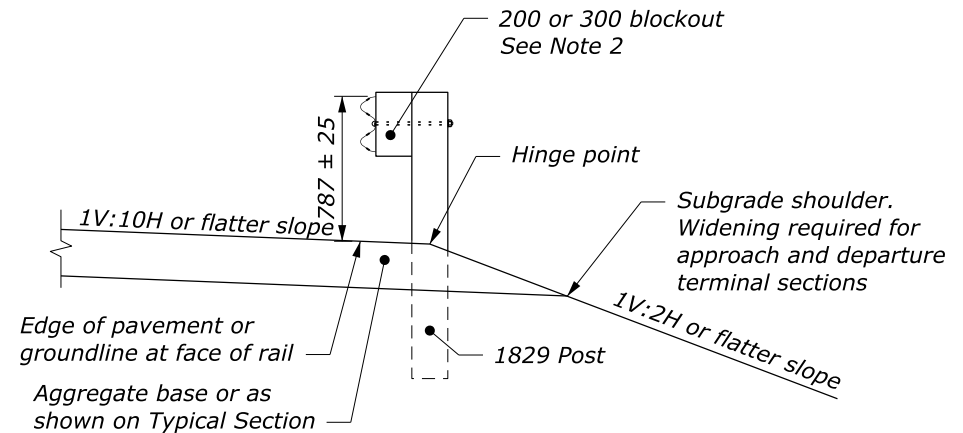

TYPICAL GUARDRAIL CROSS SECTION 1829 POST CENTERED ON HINGE, 200 OR 300 BLOCKOUT

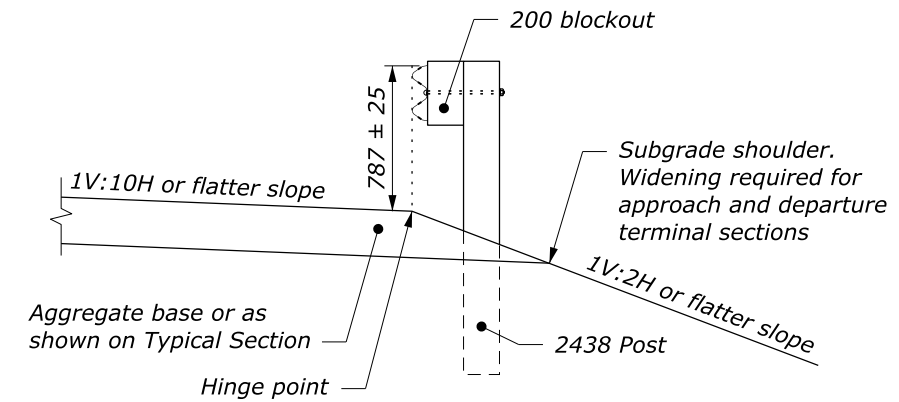

TYPICAL GUARDRAIL CROSS SECTION 2438 POST ON SLOPE, 200 BLOCKOUT

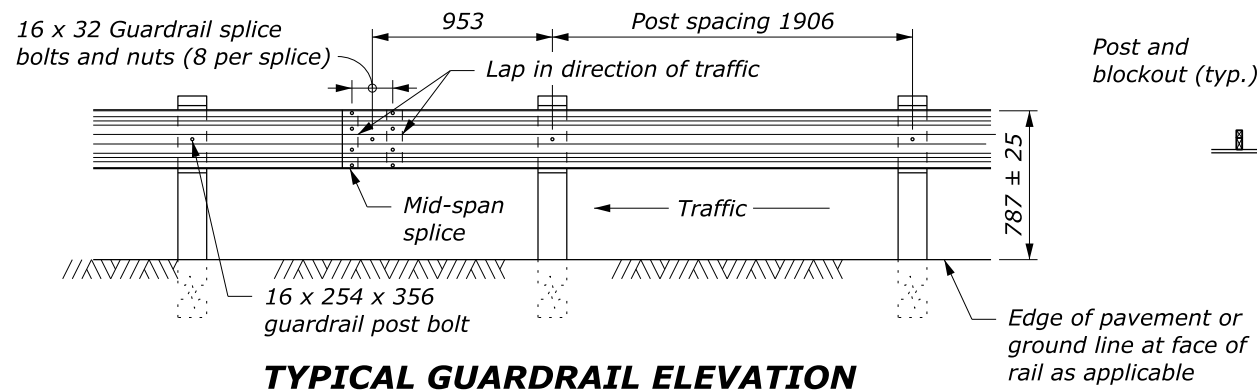

TYPICAL GUARDRAIL ELEVATION

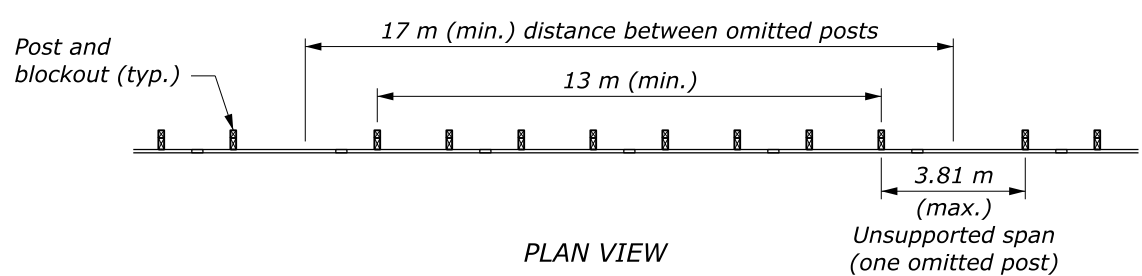

PLAN VIEW OMITTED POST DETAIL
See Note 1

This drawing contains **Metric** units of measure. Dimensions without units are millimeters.

U.S. DEPARTMENT OF TRANSPORTATION, FHWA OFFICE OF FEDERAL LANDS HIGHWAY	FLH STANDARD M617-32
MGS W-BEAM GUARDRAIL STEEL POSTS	SPECIFICATION FP-14
	APPROVED FOR USE 2/2024

NO SCALE

c:\pwwork\0419223\Std617-32\p14.dwg [Std M617-32] 10 July 2024 9:35 AM