

SECTION A-A

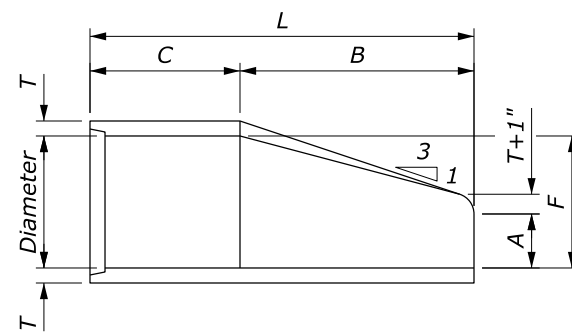
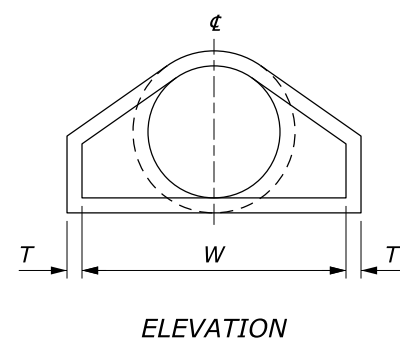
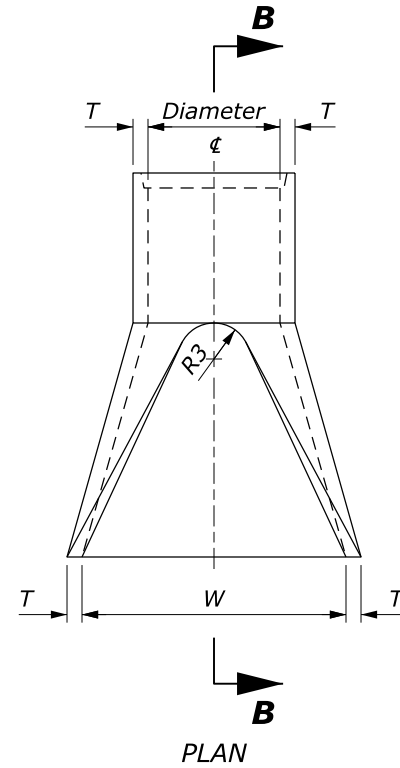

SECTION A-A

NOTE:

1. Variations in design and dimensions are permitted to allow for manufacturer's standards.
2. Fabricate the outlet end section with a groove end and the inlet end section with a tongue end.
3. Warp embankment slopes to match the slope of the flared end section.

END SECTIONS FOR ROUND PIPE CULVERT

PIPE SIZE DIAMETER inch	DIMENSIONS inch									
	T	A	B	C	L	W	F	R1	R2	R3
12	2	4	24	48 ⁷ / ₈	72 ⁷ / ₈	24	13	10 ¹ / ₈	9	4
15	2 ¹ / ₄	6	27	46	73	30	16	12 ¹ / ₂	11	6
18	2 ¹ / ₂	9	27	46	73	36	19	15 ¹ / ₂	12	7 ¹ / ₂
21	2 ³ / ₄	9	36	37	73	42	22	16 ¹ / ₂	13	5
24	3	9 ¹ / ₂	43 ¹ / ₂	30	73 ¹ / ₂	48	25	16 ³ / ₄	14	8
27	3 ¹ / ₄	10 ¹ / ₂	49 ¹ / ₂	24	73 ¹ / ₂	54	28	--	14 ¹ / ₂	9
30	3 ¹ / ₂	12	54	19 ³ / ₄	73 ³ / ₄	60	31	18 ¹ / ₂	15	8
33	3 ³ / ₄	13 ¹ / ₂ "	58 ¹ / ₂	37 ¹ / ₂	96	66	34	23 ³ / ₄	17 ¹ / ₂	9
36	4	15	63	33	96	72	37	23 ¹ / ₄	20	11
42	4 ¹ / ₂	21	63	33	96	78	43	--	22	11
48	5	24	72	24	96	84	49	--	22	12

NO SCALE

U.S. DEPARTMENT OF TRANSPORTATION, FHWA
OFFICE OF FEDERAL LANDS HIGHWAY

**CONCRETE END SECTION
FOR ROUND PIPE**

FLH STANDARD
602-8

SPECIFICATION
FP-24, FP-14

APPROVED FOR USE
1/2024

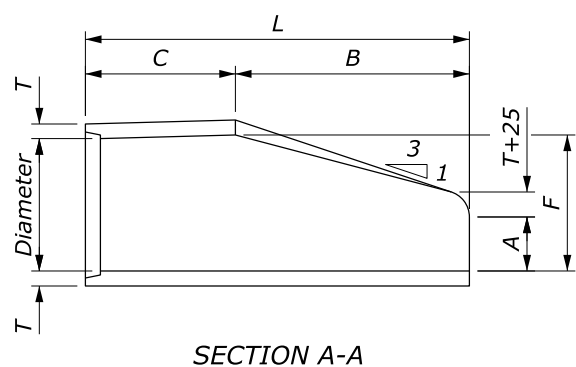
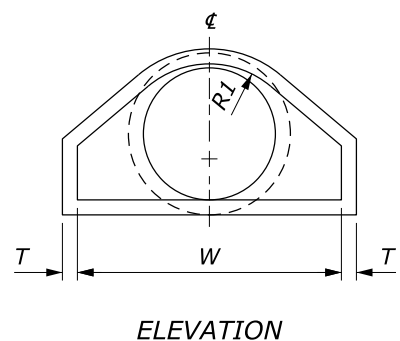
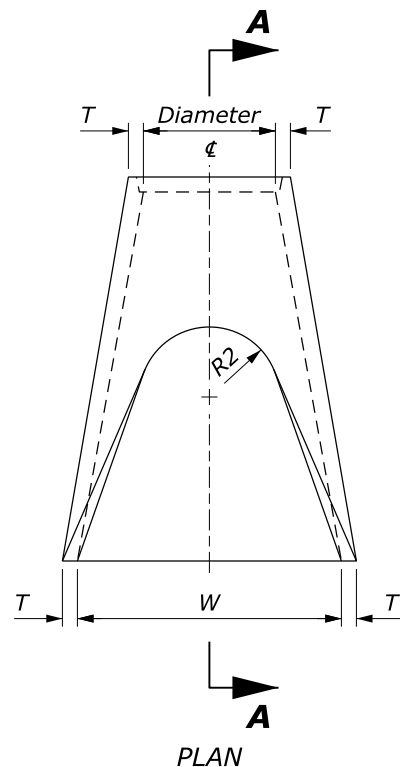

SECTION A-A

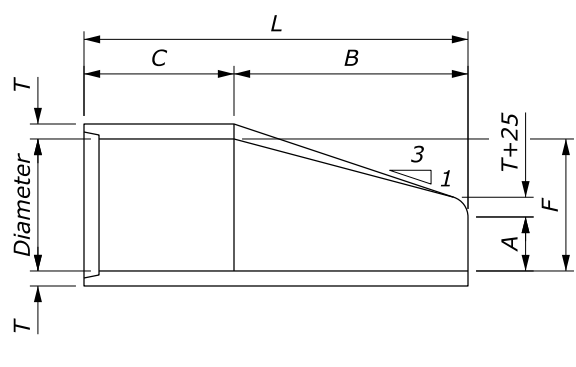
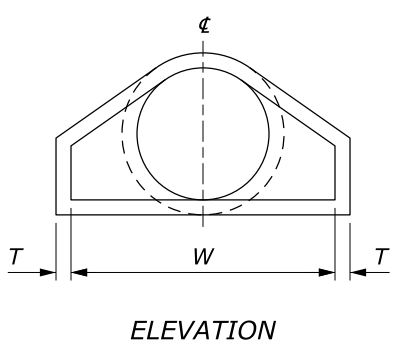
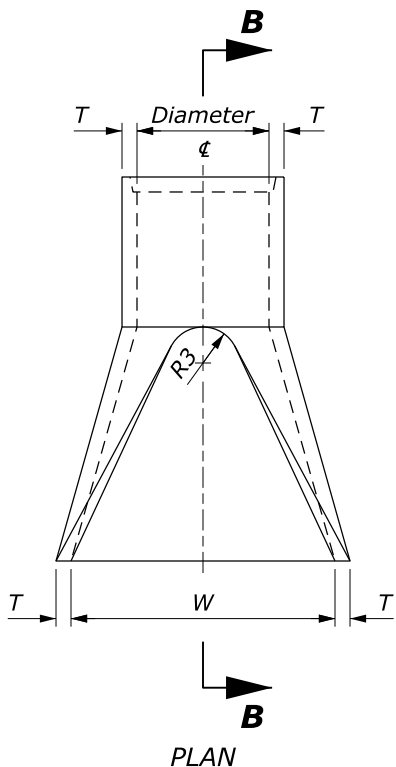

SECTION A-A

NOTE:

1. Variations in design and dimensions are permitted to allow for manufacturer's standards.
2. Fabricate the outlet end section with a groove end and the inlet end section with a tongue end.
3. Warp embankment slopes to match the slope of the flared end section.

END SECTIONS FOR ROUND PIPE CULVERT

PIPE SIZE DIAMETER	DIMENSIONS									
	T	A	B	C	L	W	F	R1	R2	R3
300	50	100	600	1222	1822	600	325	253	225	100
375	57	150	675	1150	1825	750	400	312	275	150
450	63	225	675	1150	1825	900	475	388	300	188
525	69	225	900	925	1825	1050	550	412	325	125
600	75	238	1088	750	1838	1200	625	420	350	200
675	82	263	1200	638	1838	1350	700	--	362	225
750	88	300	1350	494	1844	1500	775	462	375	200
825	94	345	1485	938	2400	1650	865	594	438	225
900	100	375	1585	825	2400	1800	925	580	500	275
1050	113	525	1585	825	2400	1950	1095	--	550	275
1200	125	600	1800	600	2400	2100	1225	--	550	300

This drawing contains **Metric** units of measure.
Dimensions without units are millimeters.

U.S. DEPARTMENT OF TRANSPORTATION, FHWA
OFFICE OF FEDERAL LANDS HIGHWAY

**CONCRETE END SECTION
FOR ROUND PIPE**

FLH STANDARD
M602-8

SPECIFICATION
FP-24, FP-14

APPROVED FOR USE
1/2024

NO SCALE