

ABOVE NATURAL GROUND

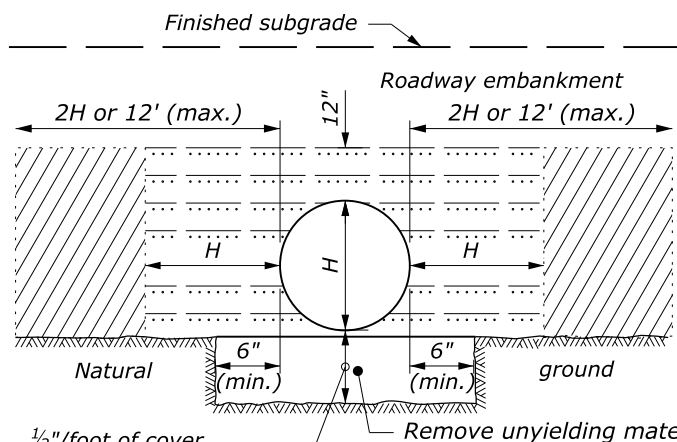

ON UNYIELDING MATERIAL

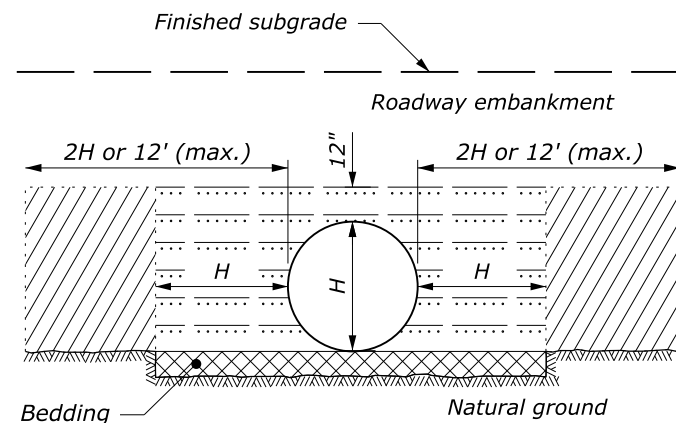

ON NATURAL GROUND

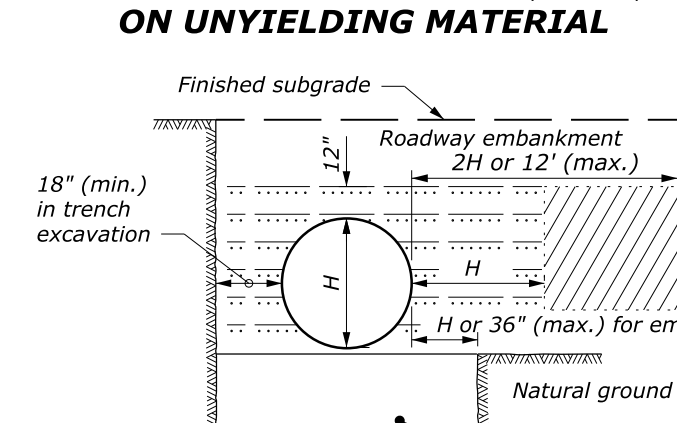

ON UNSTABLE MATERIAL

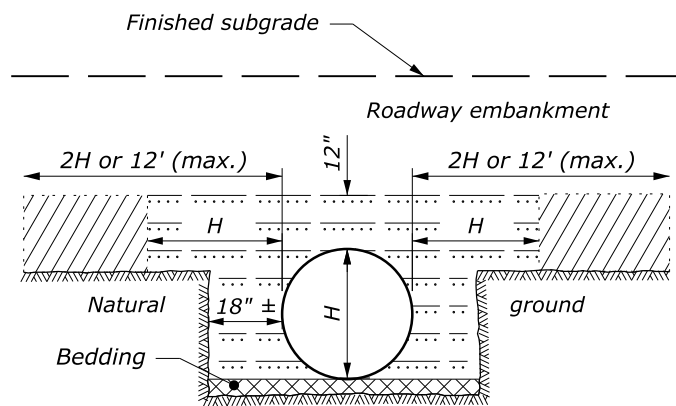

ABOVE AND BELOW NATURAL GROUND

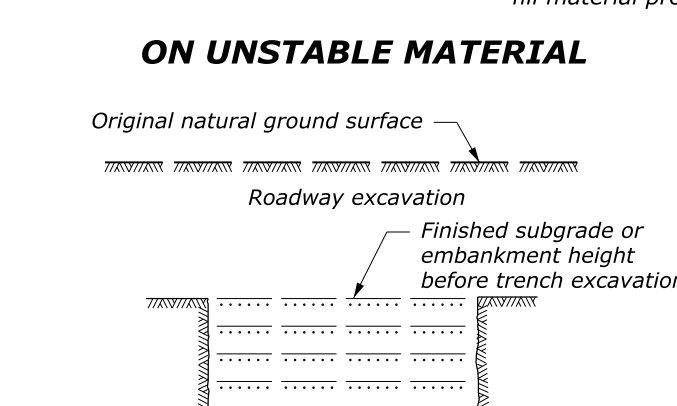

BELOW NATURAL GROUND OR TRENCH EXCAVATION IN EMBANKMENT

BEDDING DEPTH	
PIPE SIZE (H)	DEPTH
12" to 54"	4"
> 54"	6"

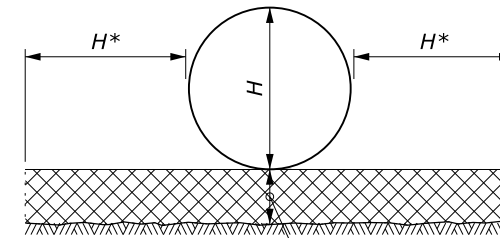

PIPE BEDDING

MINIMUM SPACING	
DIAMETER or SPAN	SPACING
UP to 48"	24"
48" and UP	Half diameter or span or 36", whichever is less

NOTE:

- When directed, camber pipe culverts upward from a chord through the inlet and outlet inverts an ordinate amount equal to 1% of the pipe length. Develop camber on a parabolic curve. If the midpoint elevation on the parabolic curve as designed exceeds the elevation of the inlet invert, reduce the amount of camber or increase the pipe culvert gradient.
- H equals the diameter of all round pipe culverts or the rise dimension of all pipe arch culverts.
- See Section 704 for bedding and backfill requirements.

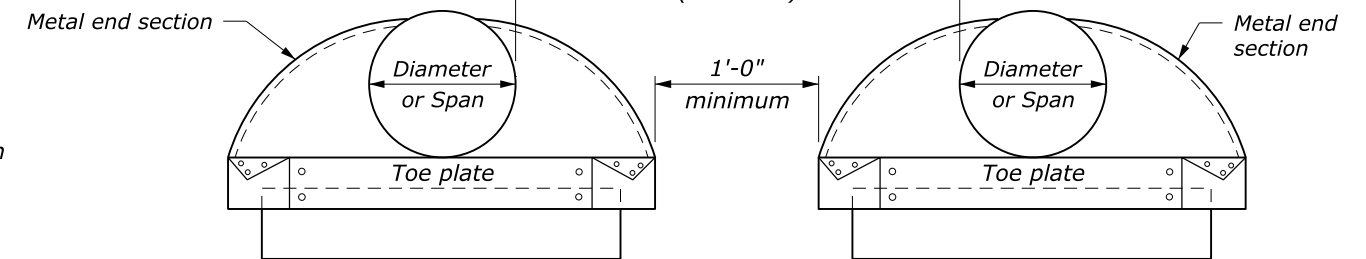

ELEVATION

MULTIPLE PIPE INSTALLATION

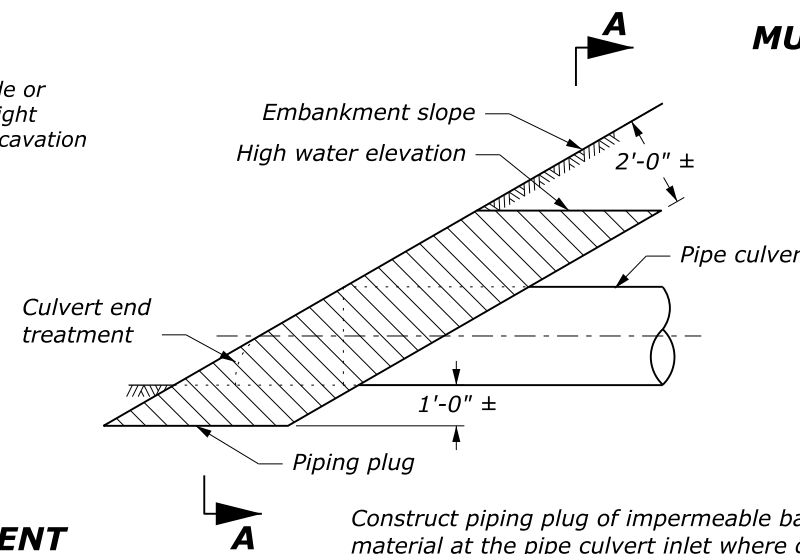

Construct piping plug of impermeable backfill material at the pipe culvert inlet where granular material is used for backfill. Width may be adjusted to tie into impervious material.

PIPING PLUG

NO SCALE

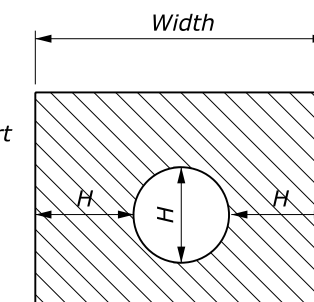

SECTION A-A

LEGEND:

- Bedding material (uncompacted)
- Embankment material placed in layers not exceeding 6" compacted depth.
- Compacted backfill material placed in layers not exceeding 6" compacted depth; or lean concrete backfill according to Section 614.
- Impermeable backfill material.

U.S. DEPARTMENT OF TRANSPORTATION, FHWA OFFICE OF FEDERAL LANDS HIGHWAY	FLH STANDARD 602-3
METAL AND PLASTIC PIPE CULVERT BEDDING	SPECIFICATION FP-14
	APPROVED FOR USE 1/2024

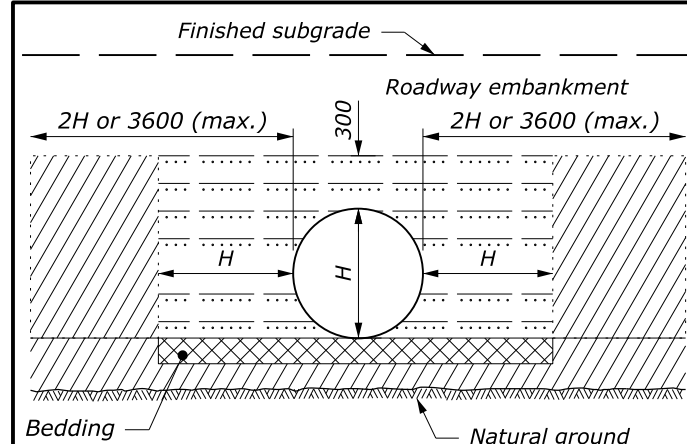

ABOVE NATURAL GROUND

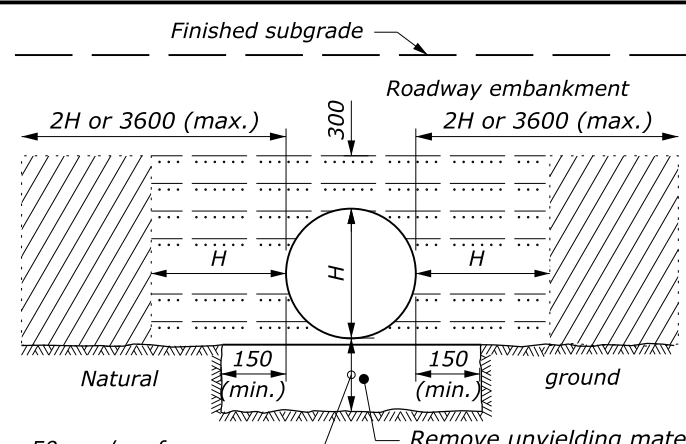

ON UNYIELDING MATERIAL

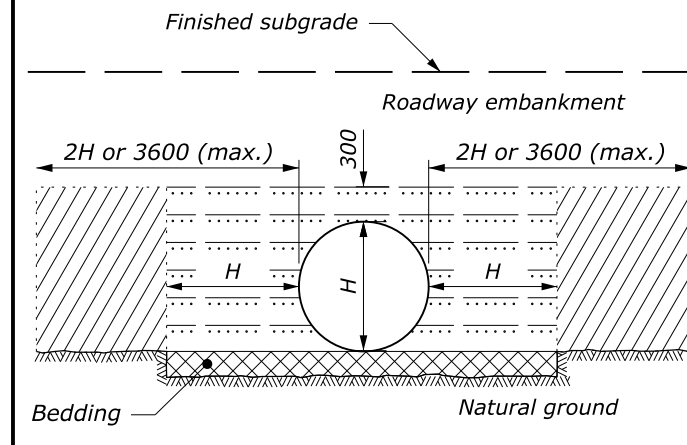

ON NATURAL GROUND

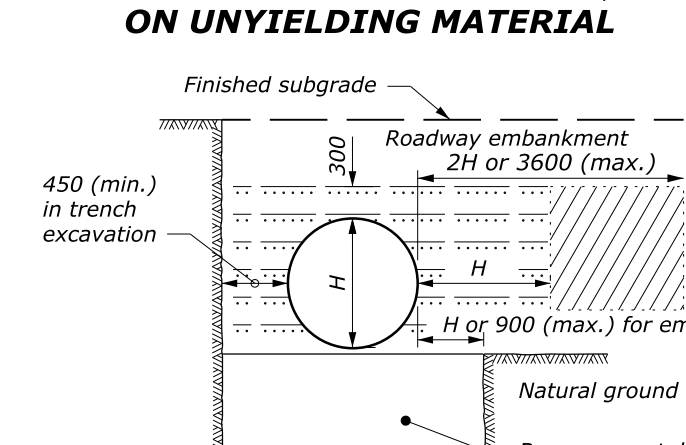

ON UNSTABLE MATERIAL

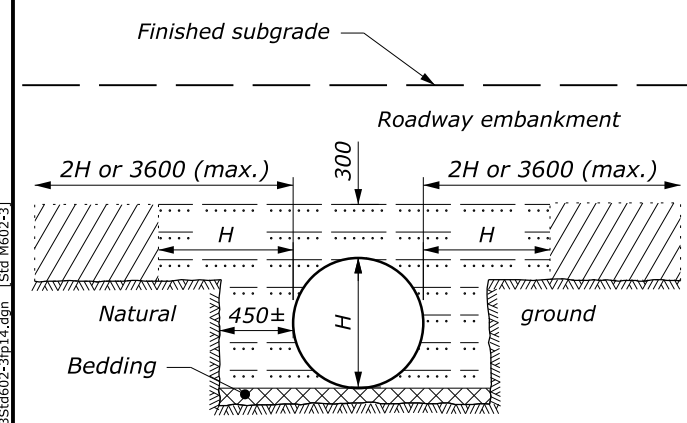

ABOVE AND BELOW NATURAL GROUND

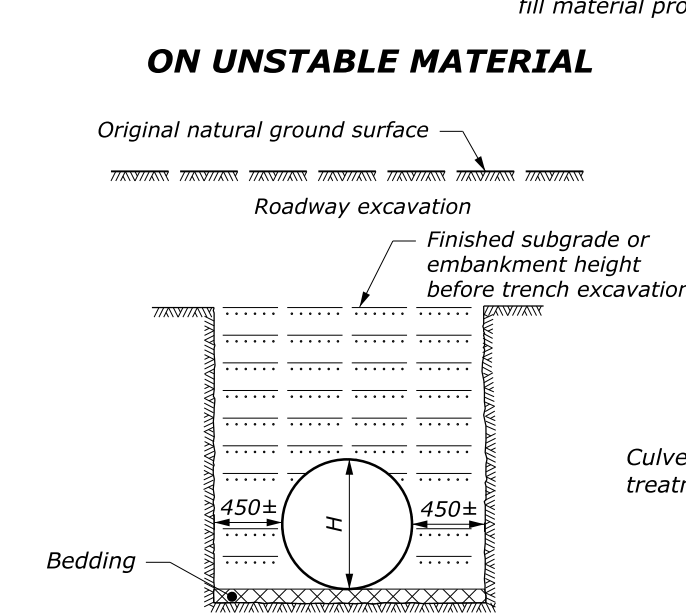

BELOW NATURAL GROUND OR TRENCH EXCAVATION IN EMBANKMENT

BEDDING DEPTH	
PIPE SIZE (H)	DEPTH
300 to 1350	100
> 1350	150

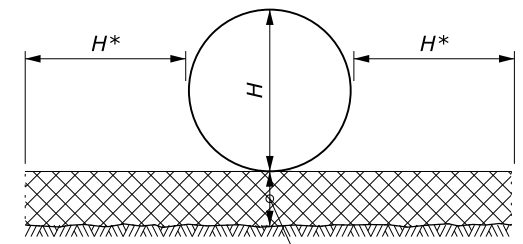

PIPE BEDDING

* Reduce to 450 for trench excavations See bedding depth table

NOTE:

1. When directed, camber pipe culverts upward from a chord through the inlet and outlet inverts an ordinate amount equal to 1% of the pipe length. Develop camber on a parabolic curve. If the midpoint elevation on the parabolic curve as designed exceeds the elevation of the inlet invert, reduce the amount of camber or increase the pipe culvert gradient.
2. H equals the diameter of all round pipe culverts or the rise dimension of all pipe arch culverts.
3. See Section 704 for bedding and backfill requirements.

MINIMUM SPACING	
DIAMETER or SPAN	SPACING
UP to 1200	610
1200 and UP	Half diameter or span or 900, whichever is less

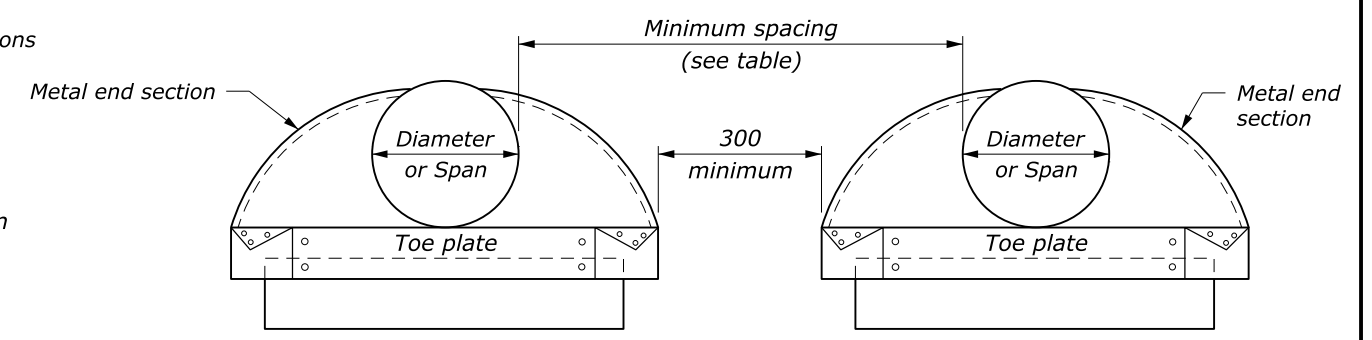

ELEVATION

MULTIPLE PIPE INSTALLATION

- LEGEND:**
- Bedding material (uncompacted)
 - Embankment material placed in layers not exceeding 150 mm compacted depth.
 - Compacted backfill material placed in layers not exceeding 150 mm compacted depth; or lean concrete backfill according to Section 614.
 - Impermeable backfill material.

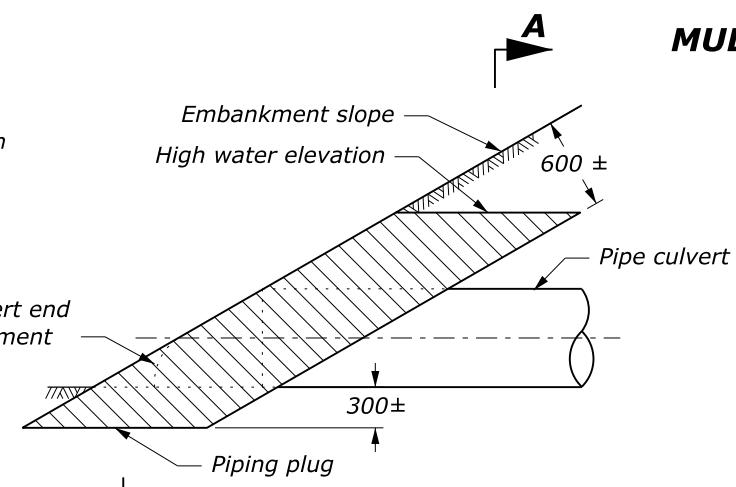

PIPING PLUG

Construct piping plug of impermeable backfill material at the pipe culvert inlet where granular material is used for backfill. Width may be adjusted to tie into impervious material.

NO SCALE

This drawing contains **Metric** units of measure. Dimensions without units are millimeters.

U.S. DEPARTMENT OF TRANSPORTATION, FHWA OFFICE OF FEDERAL LANDS HIGHWAY	FLH STANDARD M602-3
METAL AND PLASTIC PIPE CULVERT BEDDING	SPECIFICATION FP-14
	APPROVED FOR USE 1/2024

c:\pwwork\0588909\Std602-3\Fp14.dwg [Std M602-3] 19 January 2024 7:45 AM