

NOTES:

1. Install copper-clad ground rod or copper plate according to Subsection 636.07.
2. Add additional lead-in cables and terminal strips as needed.

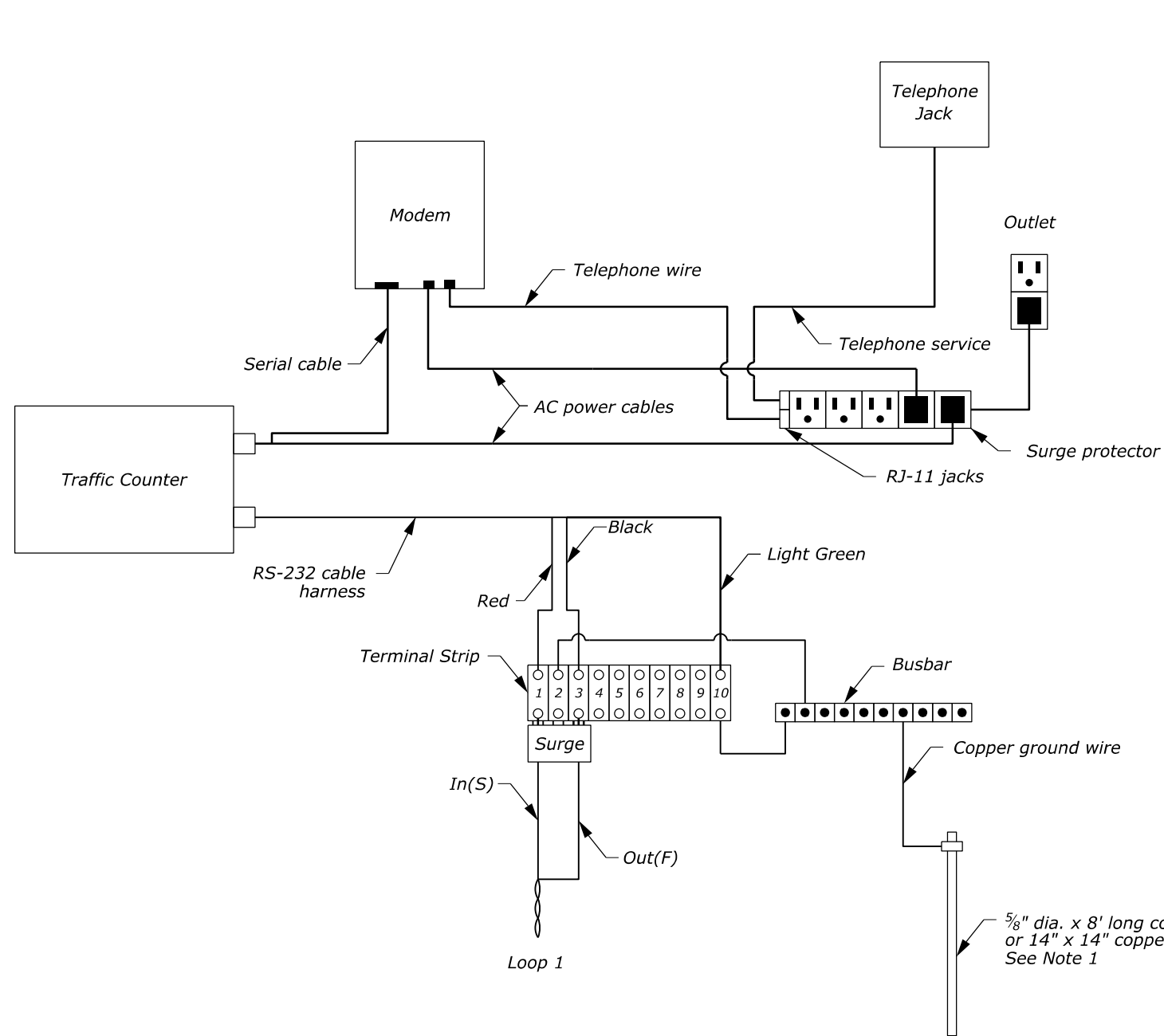

AC POWER AND MODEM

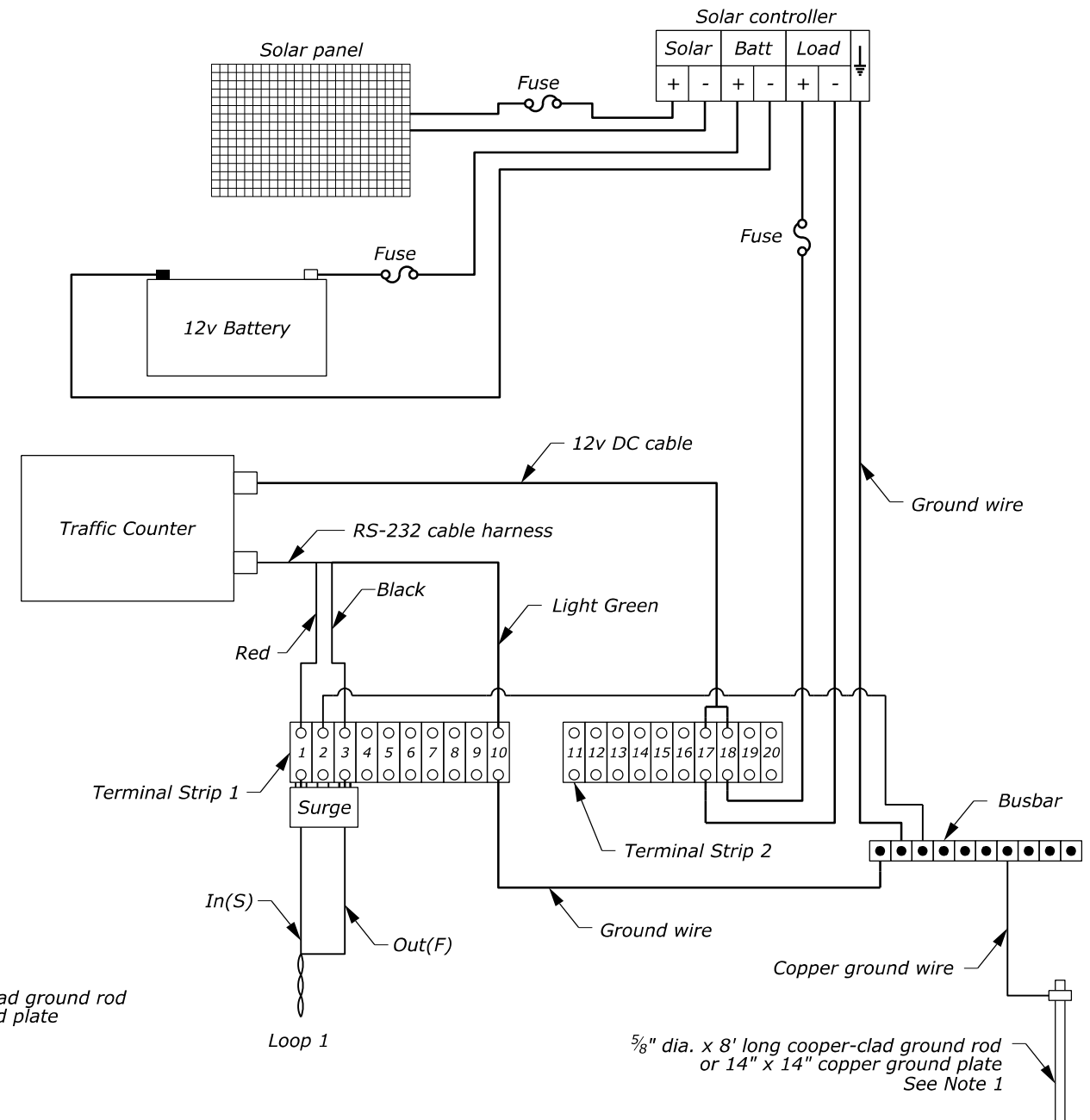

SOLAR POWER WITHOUT MODEM

NO SCALE

U.S. DEPARTMENT OF TRANSPORTATION, FHWA OFFICE OF FEDERAL LANDS HIGHWAY	EFLHD DETAIL E636-08
TRAFFIC COUNTER CABINET WIRING DIAGRAM	SPECIFICATION FP-24, FP-14
	APPROVED FOR USE 06/2024