

NOTES:

1. Form contraction joints in the corewall at 20-foot intervals.
2. Depth of foundation fill may be less than 6 inches when the foundation is on either rock fill or solid rock, as approved.
3. Set galvanized metal slots with anchors for the stone work on 2-foot spacing. Use 16 gage galvanized 1-foot by 5½-inch metal anchors. Equivalent attachment systems may be used as approved.
4. Kerf (saw cut) the capstones placed on top of the barrier to allow for their placement over the steel angle.
5. Finish exposed faces according to Subsection 620.05(d).
6. Flare guardwall ends outside the clear zone according to the Roadside Design Guide, latest edition.
7. Install metal anchor according to Subsection 620.09(b).
8. Add scuppers for roadway drainage as shown or as directed.
9. Top angle of z-clip to engage a recess cut in stone.

PRECAST CONCRETE COREWALL

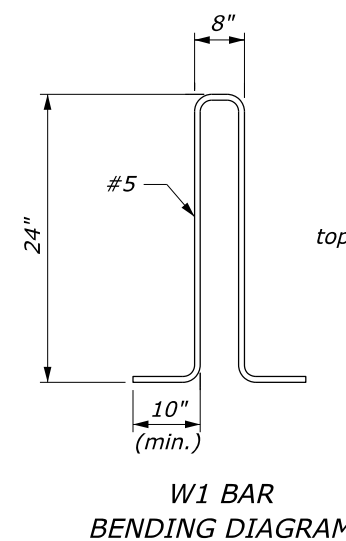
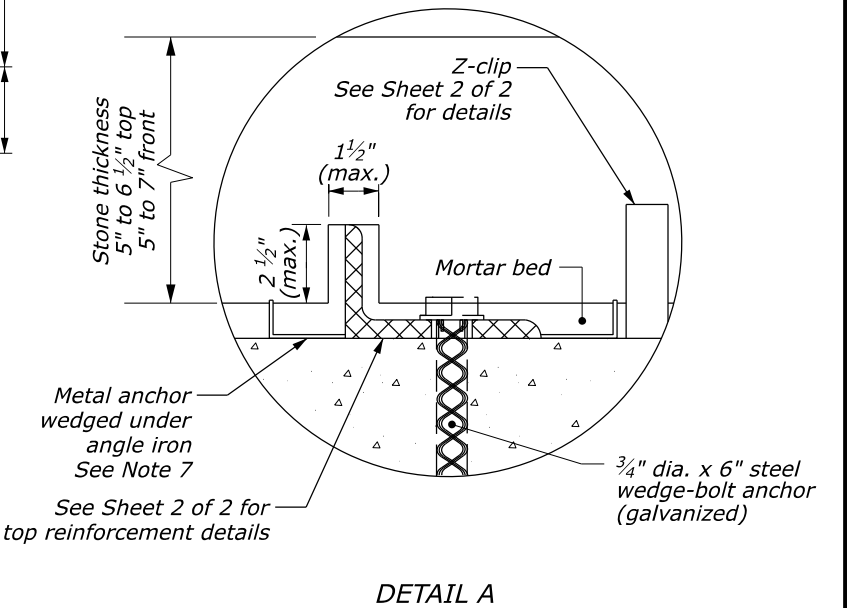
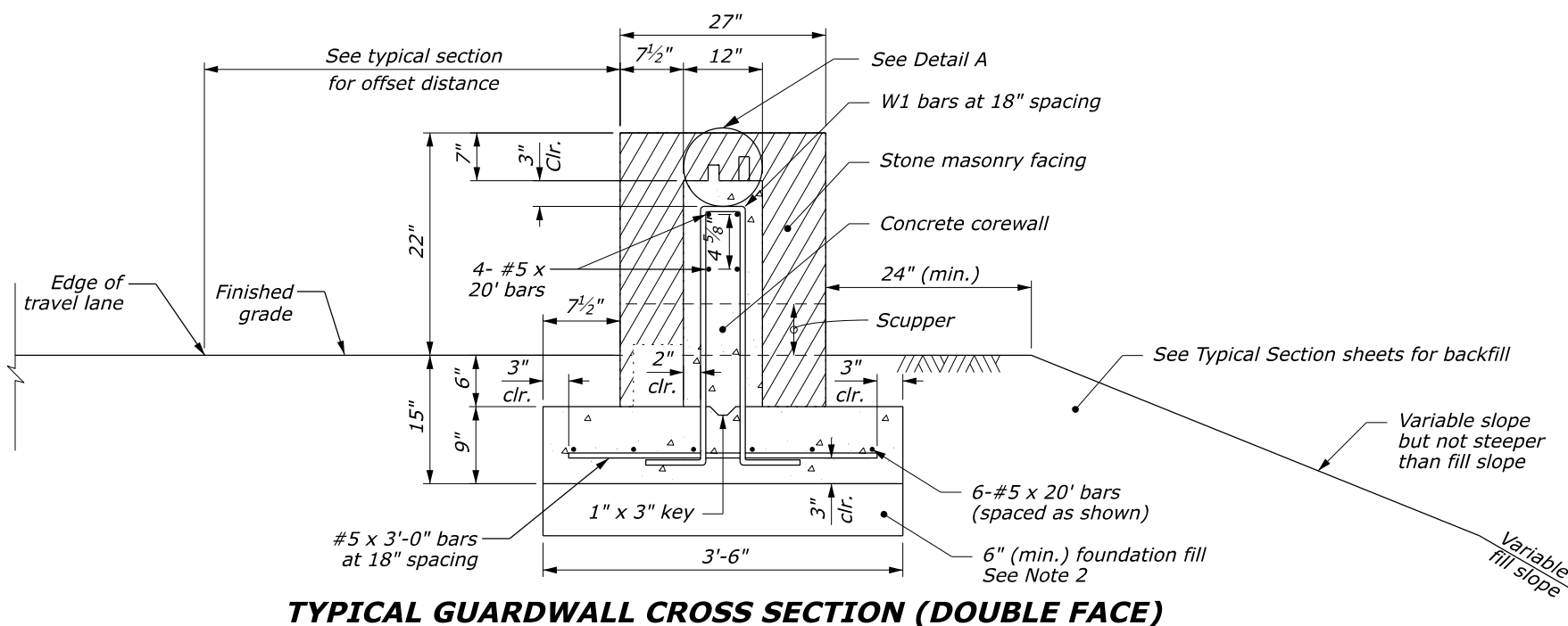

NO SCALE

U.S. DEPARTMENT OF TRANSPORTATION, FHWA OFFICE OF FEDERAL LANDS HIGHWAY	EFLHD DETAIL E620-50
TL-2 STONE MASONRY GUARDWALL (DOUBLE FACE) Sheet 1 of 2	SPECIFICATION FP-24 APPROVED FOR USE 06/2024

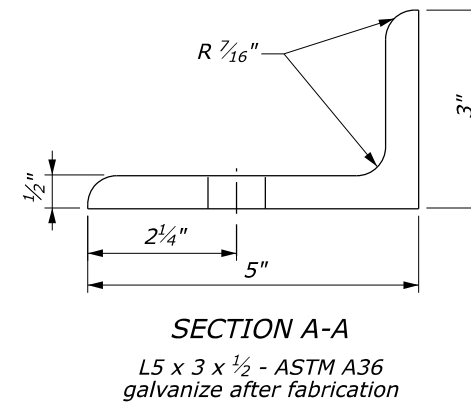
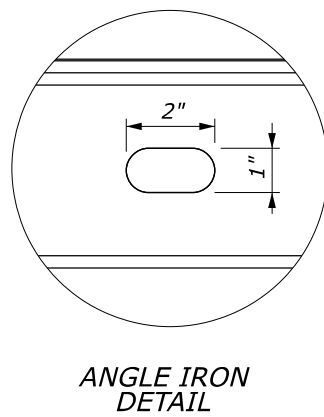
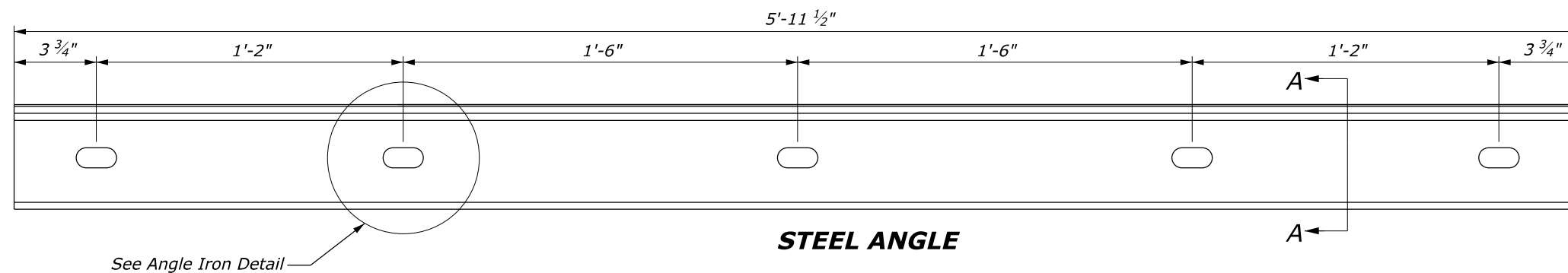

NOTES:

- Angles are used to provide lateral shear resistance for the stone masonry placed on top of the inner core wall.
- Ensure spacing between all angles is approximately 1/2 inch.
- Install metal anchor according to Subsection 620.09(b).
- Provide stainless steel conforming to ASTM A493, Type 430.

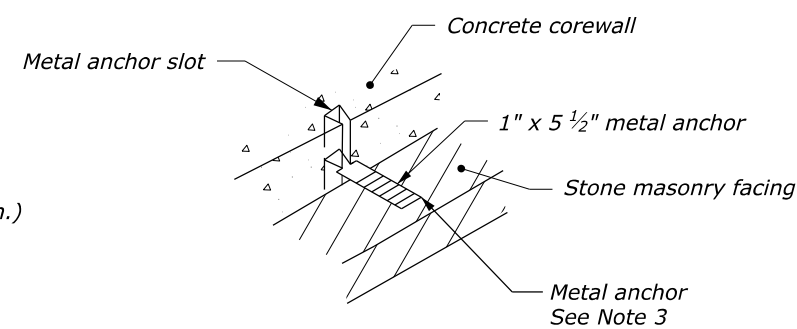
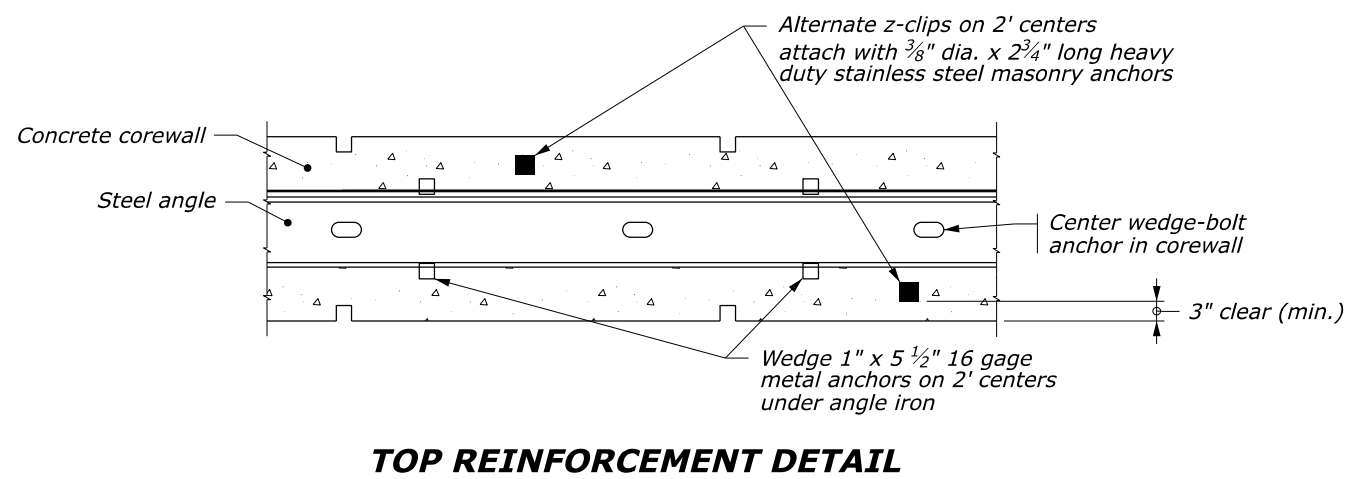
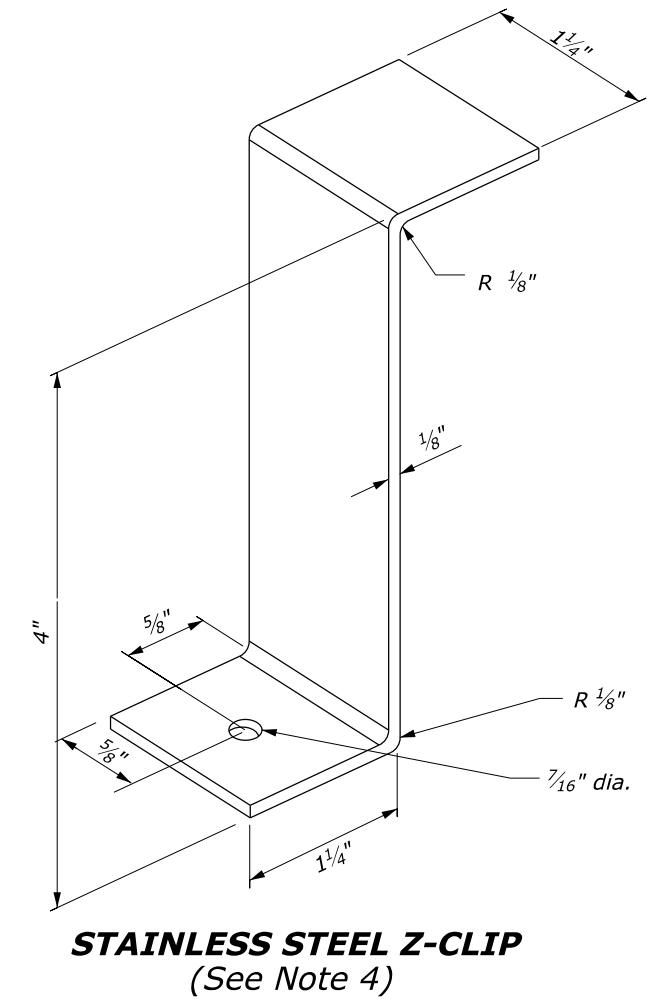

NO SCALE

U.S. DEPARTMENT OF TRANSPORTATION, FHWA OFFICE OF FEDERAL LANDS HIGHWAY	EFLHD DETAIL E620-50
TL-2 STONE MASONRY GUARDWALL (DOUBLE FACE) Sheet 2 of 2	SPECIFICATION FP-24 APPROVED FOR USE 06/2024