

NON REMOVABLE POST

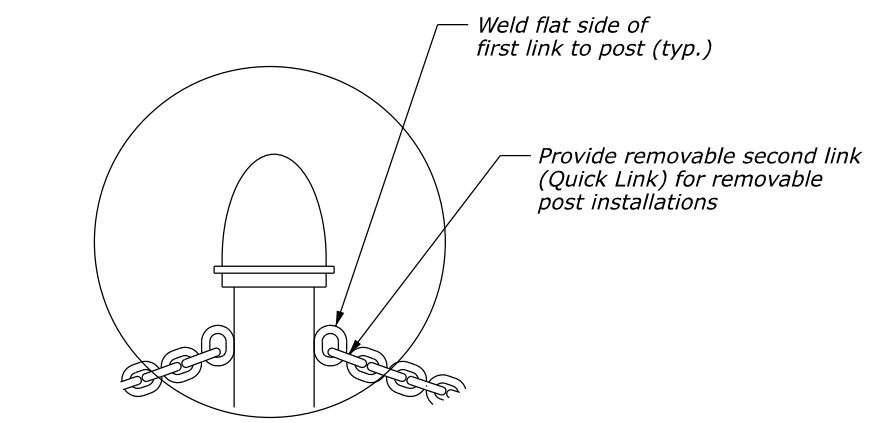

DETAIL A

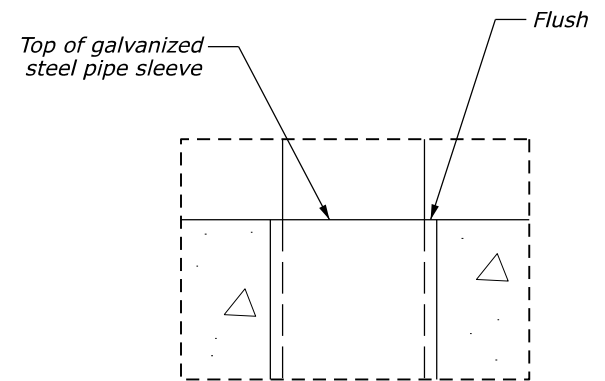

DETAIL B

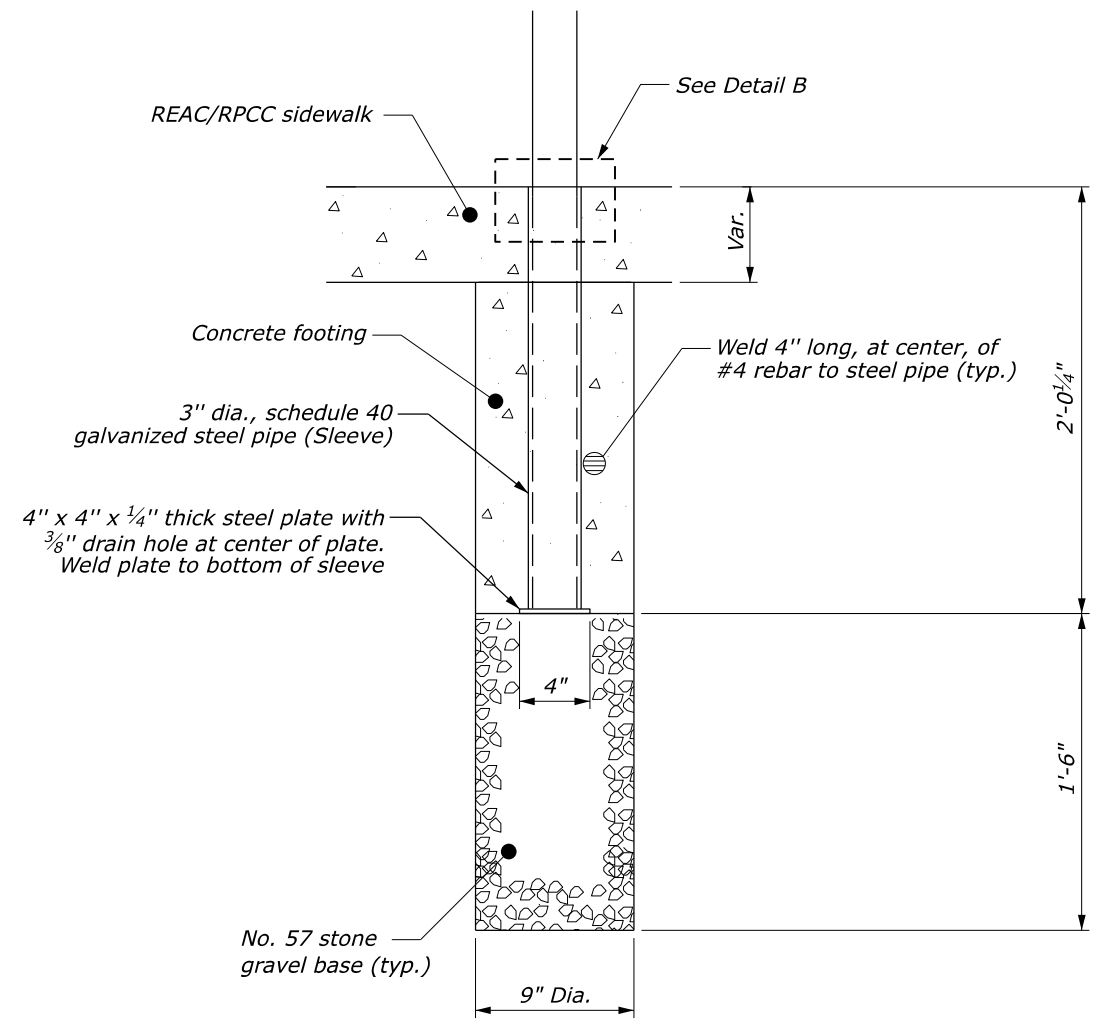

REMOVABLE POST

NOTES:

1. Paint according to Section 563.
2. Provide galvanized cast iron acorn caps conforming to Subsections 717.04 and 717.07.
3. Provide steel pipe conforming to Subsection 717.06.

NO SCALE

U.S. DEPARTMENT OF TRANSPORTATION, FHWA OFFICE OF FEDERAL LANDS HIGHWAY		EFLHD DETAIL E619-11
POST AND CHAIN		SPECIFICATION FP-14
		APPROVED FOR USE 06/2024