

PLAN

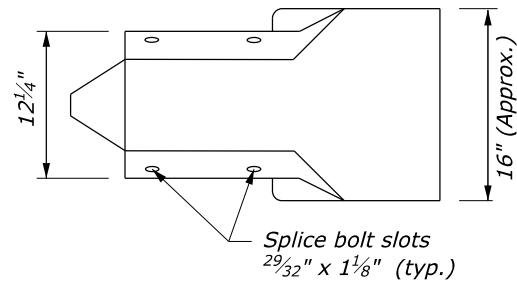

ELEVATION

ROUND END SECTION

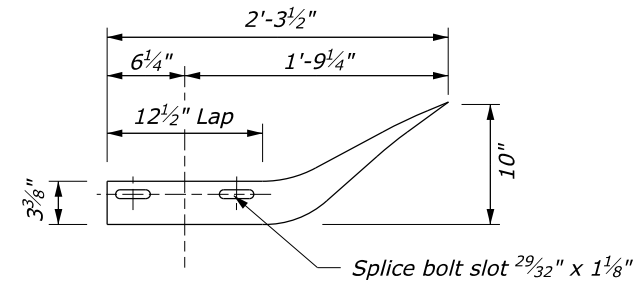

PLAN

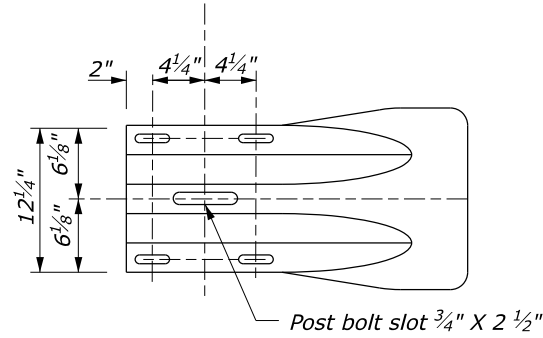

ELEVATION

FLARED END SECTION

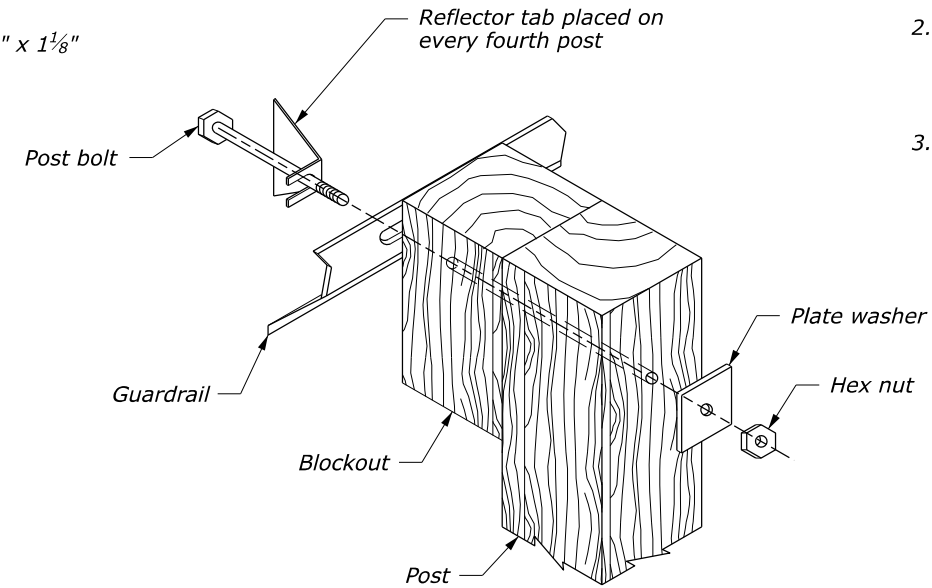

SYSTEM ASSEMBLY

NOTES:

1. Rounded or flared end sections are acceptable alternates to buffered end sections and type 1 end sections on terminal systems at the trailing ends of guardrail runs on the right side of multilane roadways and where shown in the plans on the left side of multilane roadways as approved.
2. The curb and curb and gutter shapes are shown for illustration only. Use actual curb and curb and gutter shapes and dimensions as shown in the plans.
3. Alternate reflector tab shapes are acceptable as approved.

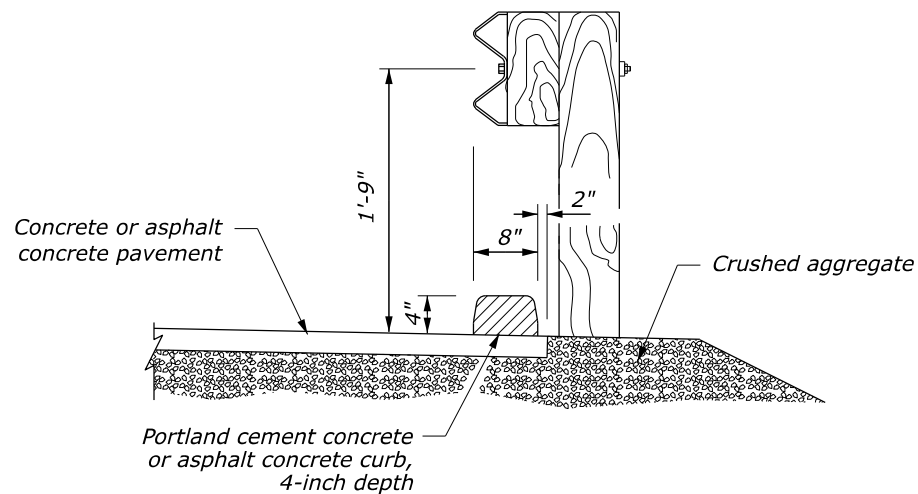

PLACEMENT OF GUARDRAIL AT CURB LOCATIONS

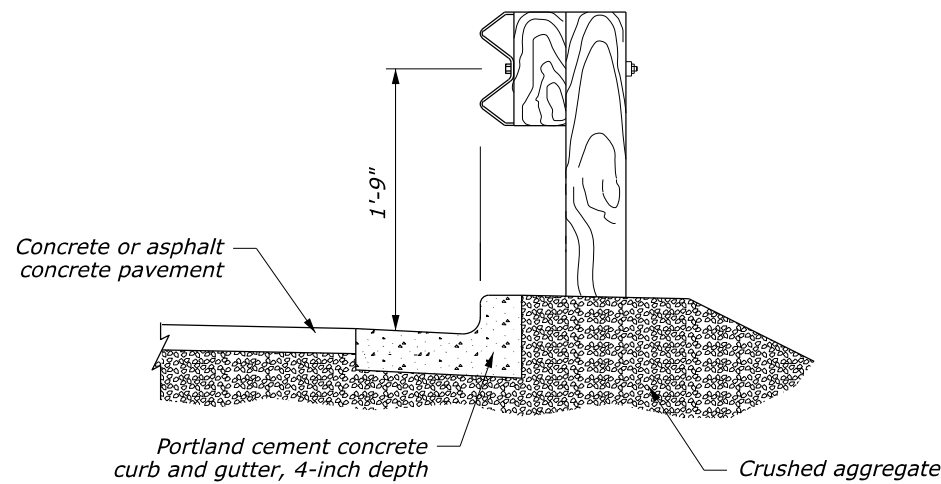

PLACEMENT OF GUARDRAIL AT CURB AND GUTTER LOCATIONS

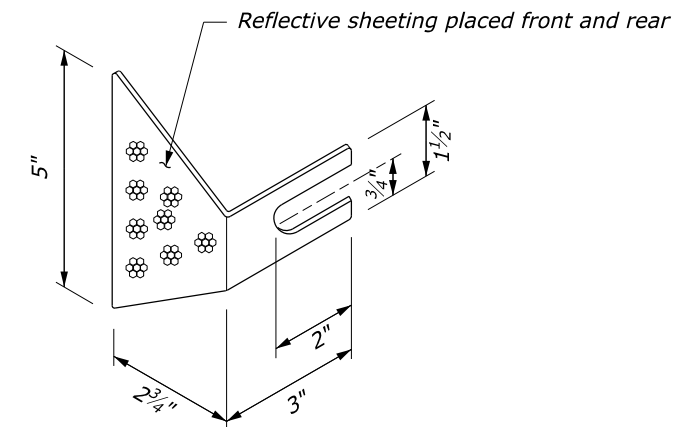

REFLECTOR TAB

NO SCALE

U.S. DEPARTMENT OF TRANSPORTATION, FHWA OFFICE OF FEDERAL LANDS HIGHWAY	EFLHD DETAIL E617-23
G4 W-BEAM GUARDRAIL SUPPLEMENT INSTALLATIONS	SPECIFICATION FP-24 APPROVED FOR USE 05/2024