

**CABLE ANCHOR PLATE DETAILS**  
ARTBA RE-71-79

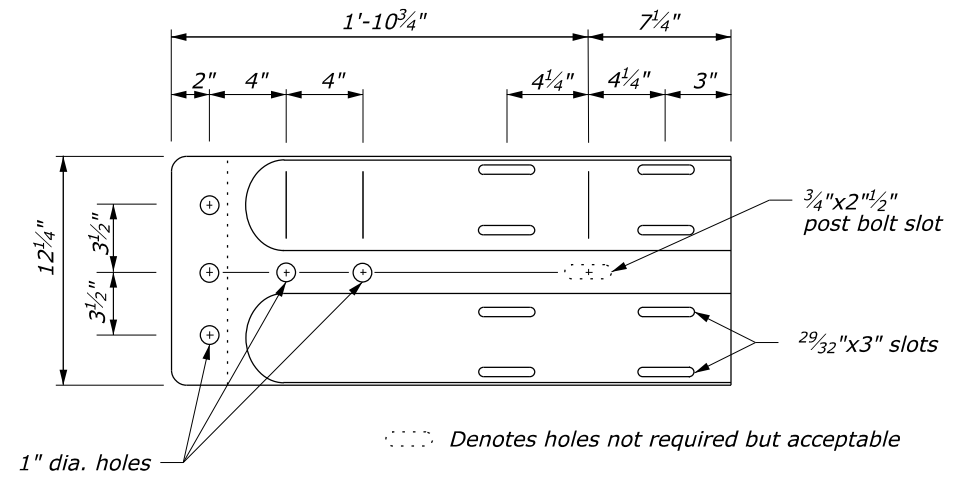

ELEVATION

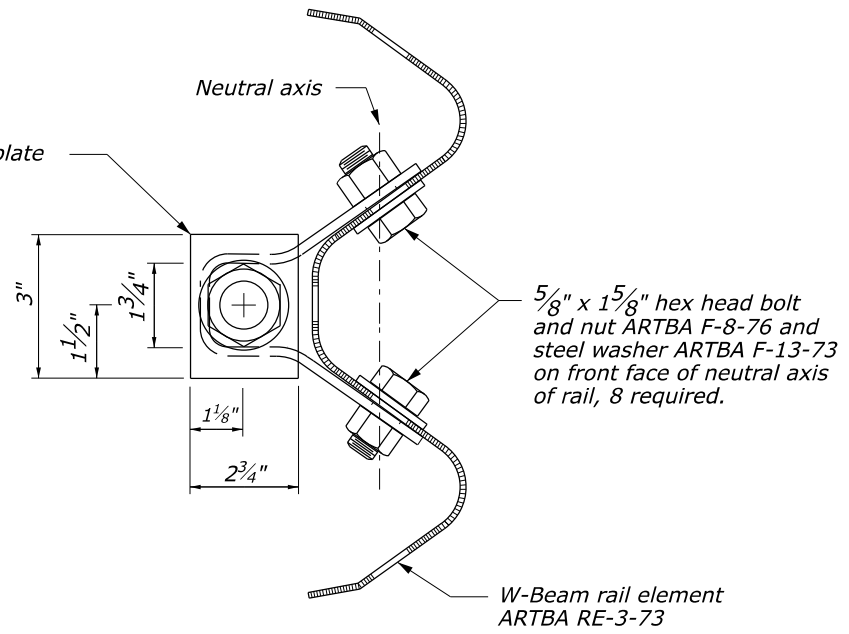
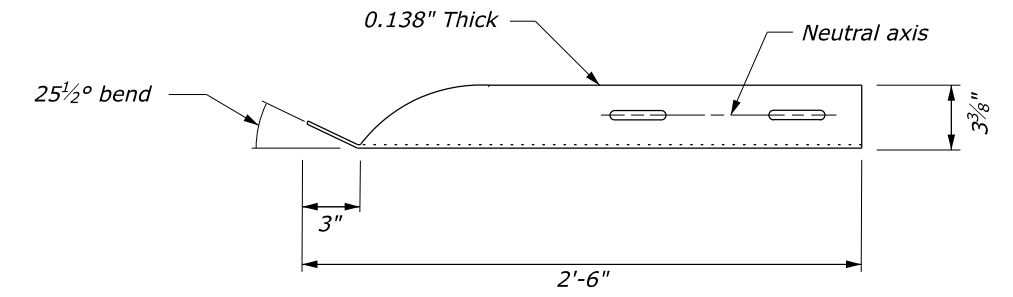

PLAN

**TERMINAL CONNECTOR**  
ARTBA RE-8-79

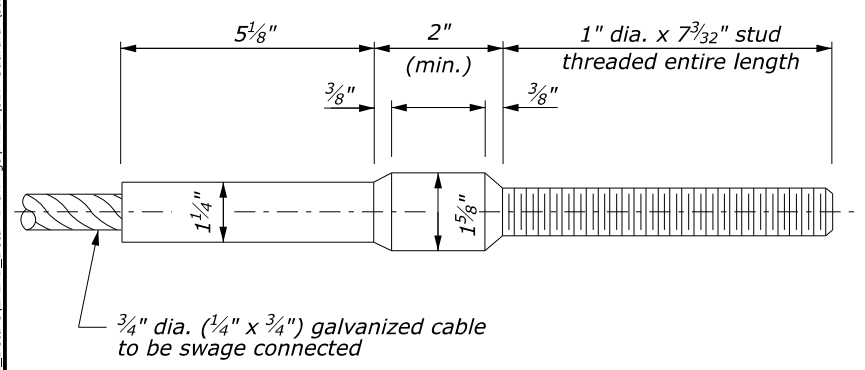

**CABLE ANCHOR ASSEMBLY**  
ARTBA F-37-76  
(Standard swaged fitting and stud)

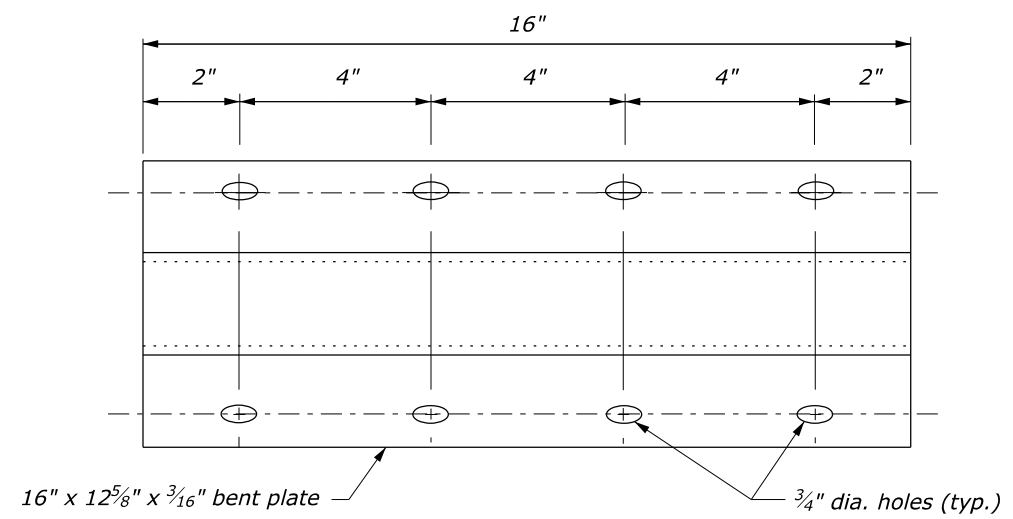

FRONT

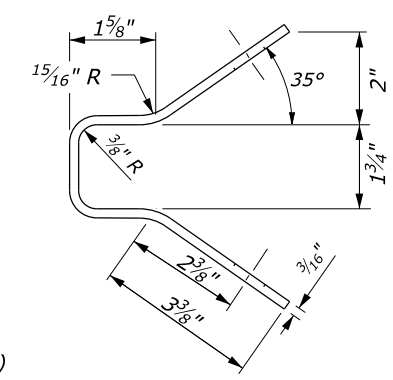

SIDE

**GURDRAIL ANCHOR BRACKET**  
ARTBA RE-71-79

NO SCALE

U.S. DEPARTMENT OF TRANSPORTATION, FHWA OFFICE OF FEDERAL LANDS HIGHWAY	EFLHD DETAIL E617-13
<b>G4 W-BEAM GUARDRAIL BCT AND MELT ANCHORAGE ASSEMBLY</b>	SPECIFICATION FP-14
	APPROVED FOR USE 05/2024

M:\Standards\_and\_Details\EFLHD\_Detail Drawings\FP-24\G17-Gurdrail\std61713\_detailfp14.dgn [Sheet] 9 May 2024 3:33 PM