

**NOTES:**

1. Use a coarse broom finish running perpendicular to the longitudinal slope on concrete surfaces, exclusive of the detectable warning surfaces.
2. Ensure the cross slopes of ramps do not exceed 2% in the direction perpendicular to the pedestrian traffic.
3. Construct curb ramp perpendicular to the curb as shown in the plans or as directed.

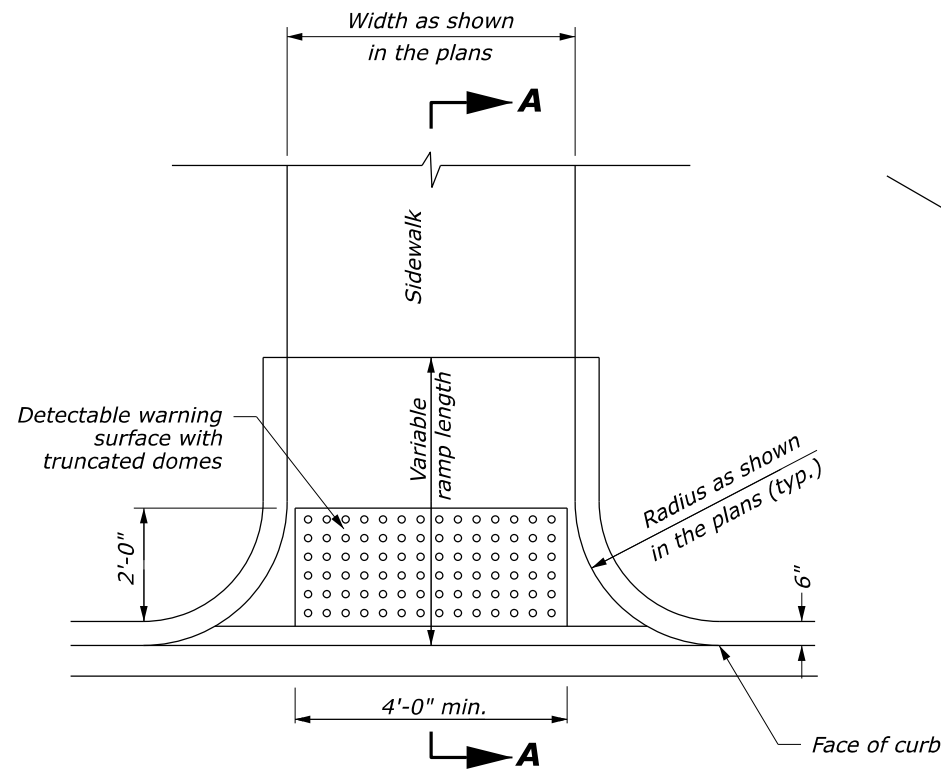

PLAN VIEW

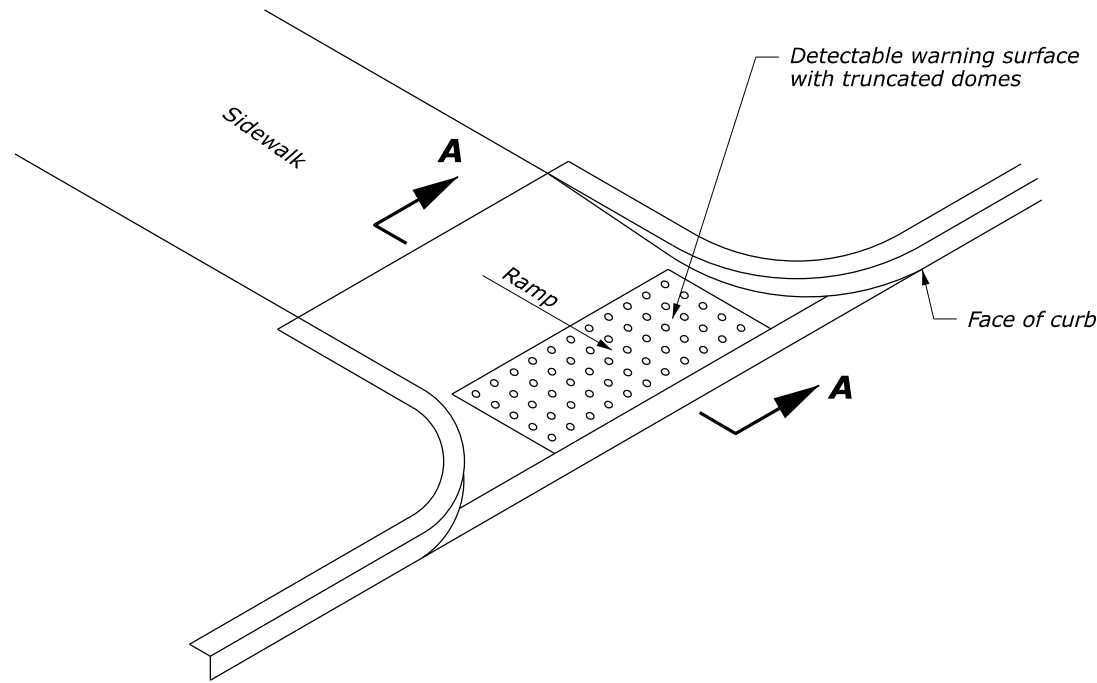

ISOMETRIC VIEW

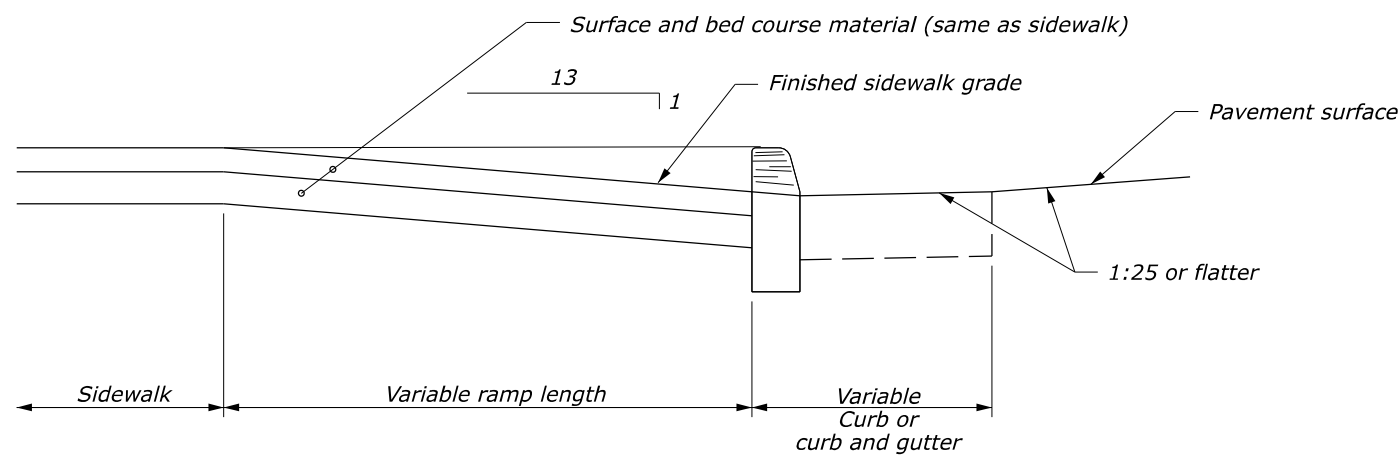

SECTION A-A

**ACCESSIBILITY RAMP**

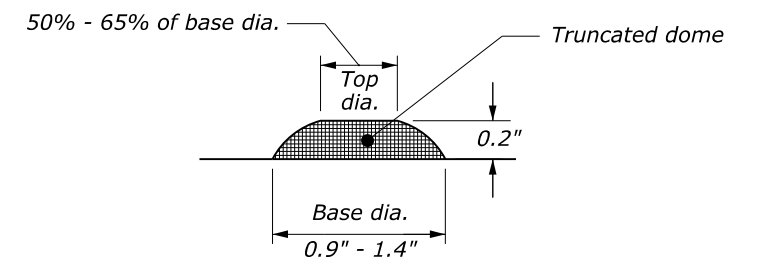

ELEVATION VIEW

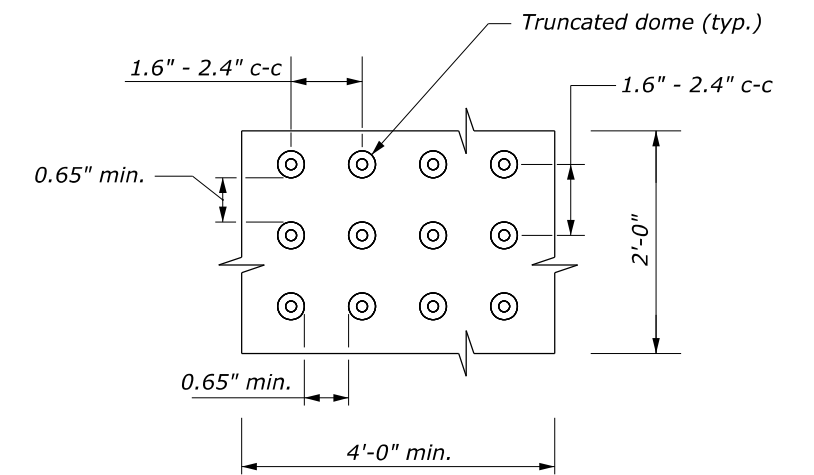

PLAN VIEW

**SIZE AND SPACING OF TRUNCATED DOMES**

NO SCALE

U.S. DEPARTMENT OF TRANSPORTATION, FHWA  
OFFICE OF FEDERAL LANDS HIGHWAY

**ACCESSIBILITY RAMP  
CURB RETURN**

EFLHD DETAIL  
E615-05

SPECIFICATION  
FP-14

APPROVED FOR USE  
05/2024