

NOTES:

1. Use a coarse broom finish running perpendicular to the longitudinal slope on concrete surfaces, exclusive of the detectable warning surfaces.
2. Ensure the cross slopes of ramps do not exceed 2% in the direction perpendicular to the pedestrian traffic.
3. Construct curb ramp perpendicular to the curb as shown in the plans or as directed.

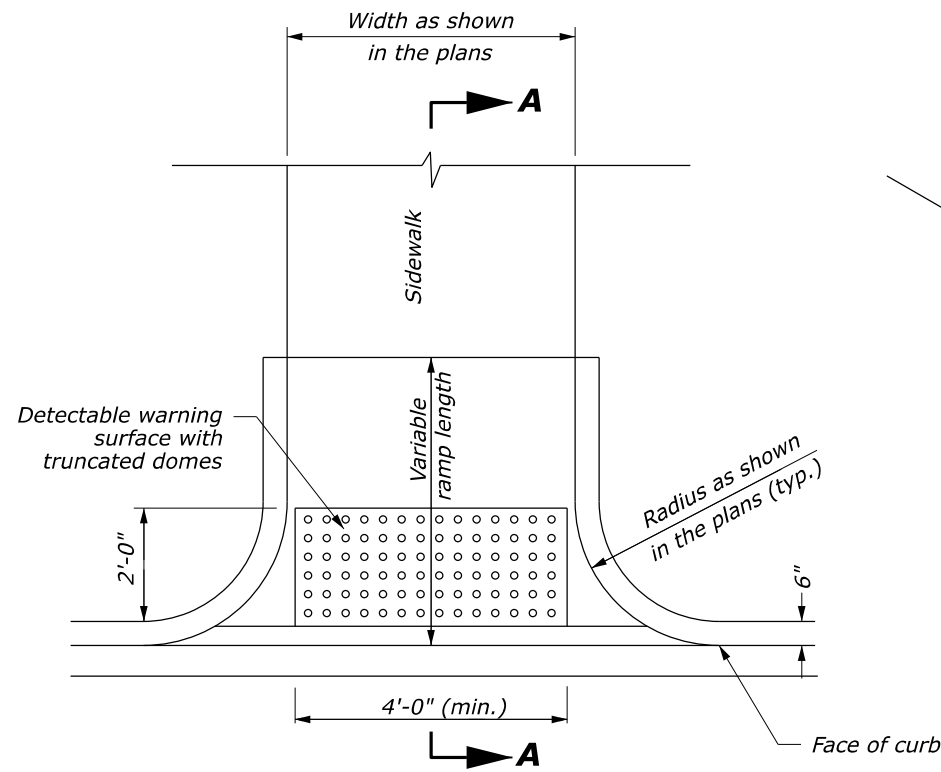

PLAN VIEW

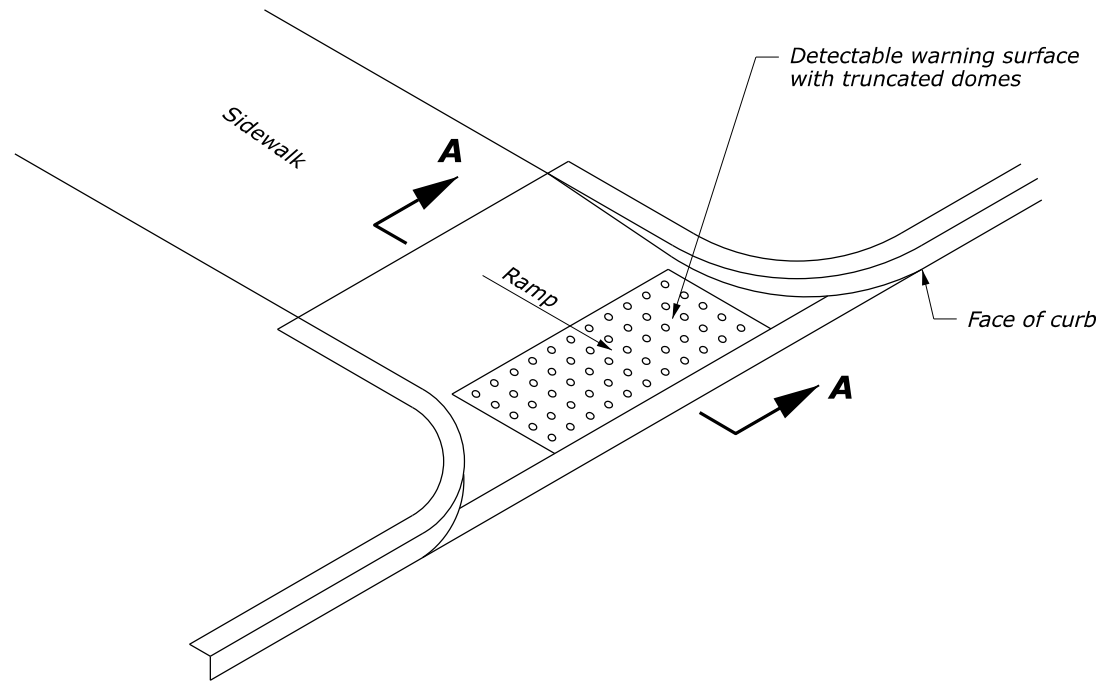

ISOMETRIC VIEW

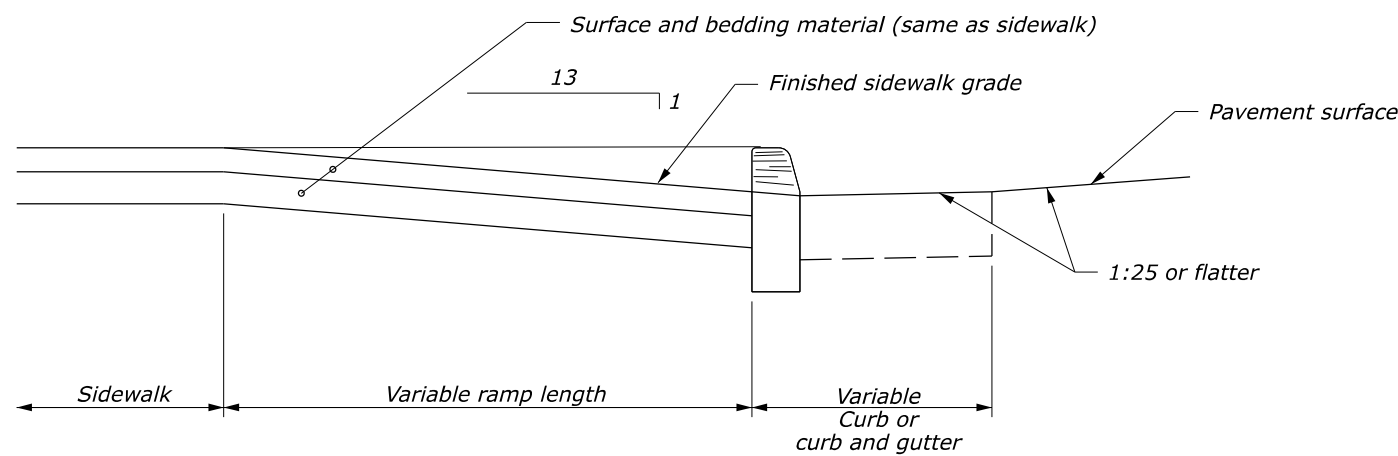

SECTION A-A

ACCESSIBILITY RAMP

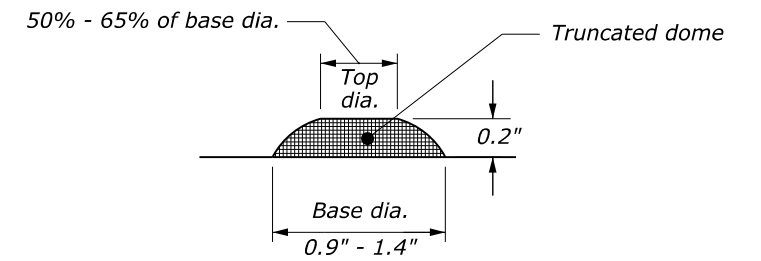

ELEVATION VIEW

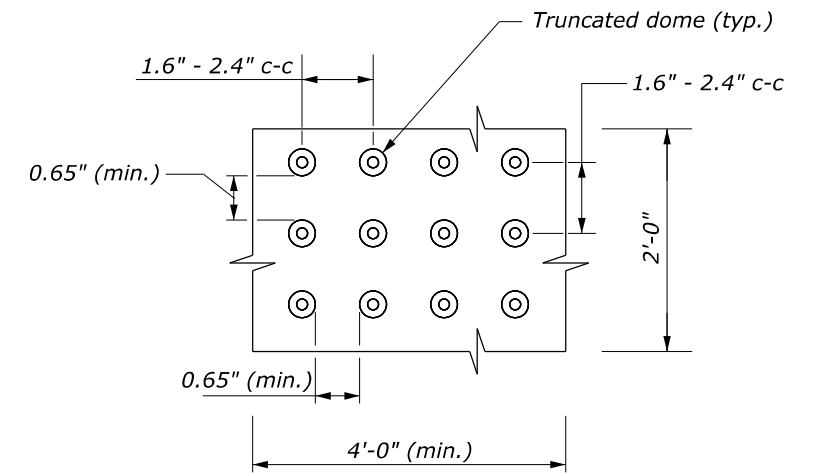

PLAN VIEW

SIZE AND SPACING OF TRUNCATED DOMES

NO SCALE

U.S. DEPARTMENT OF TRANSPORTATION, FHWA
OFFICE OF FEDERAL LANDS HIGHWAY

**ACCESSIBILITY RAMP
CURB RETURN**

EFLHD DETAIL
E610-05

SPECIFICATION
FP-24

APPROVED FOR USE
05/2024