

**NOTE:**

Place transverse expansion joints at intervals of not more than 60 feet for curbs and sidewalks.

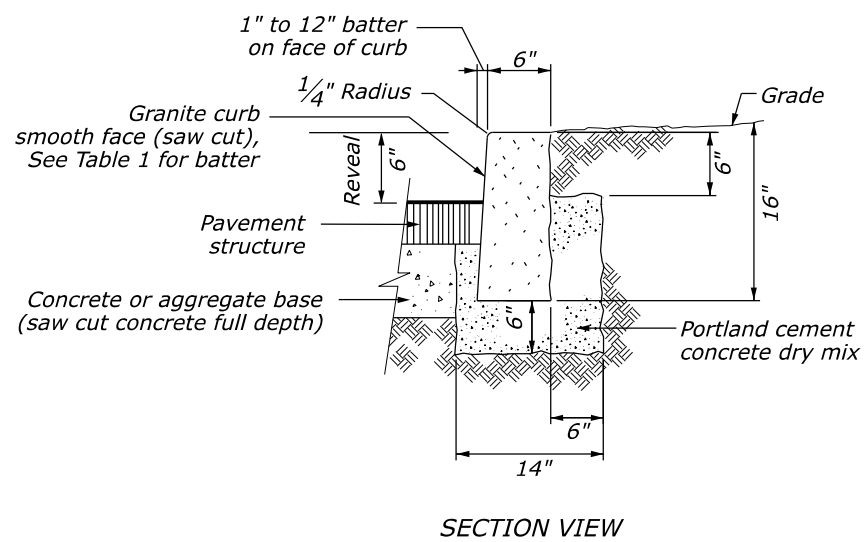

**STONE CURB TYPE 1, 16" DEPTH (GRANITE TYPE A OR B) (WITHOUT SIDEWALK)**

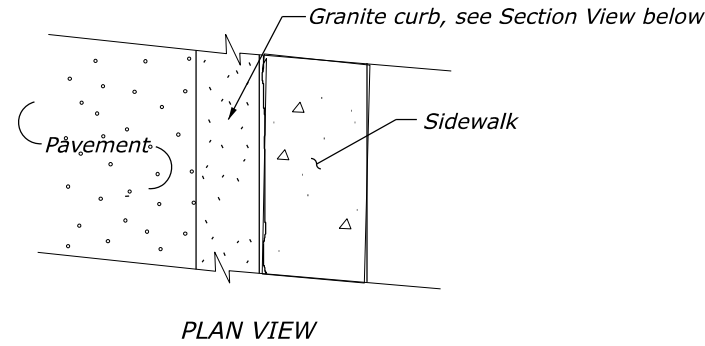
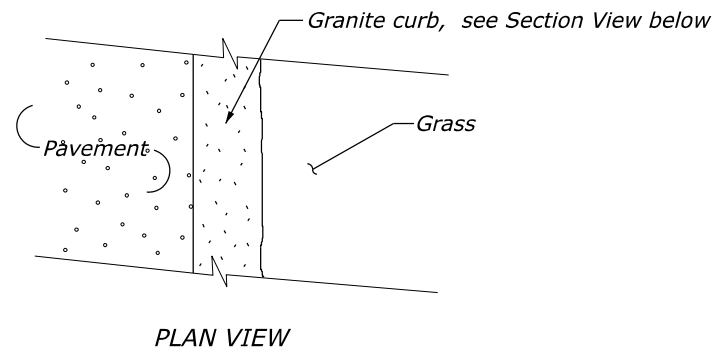
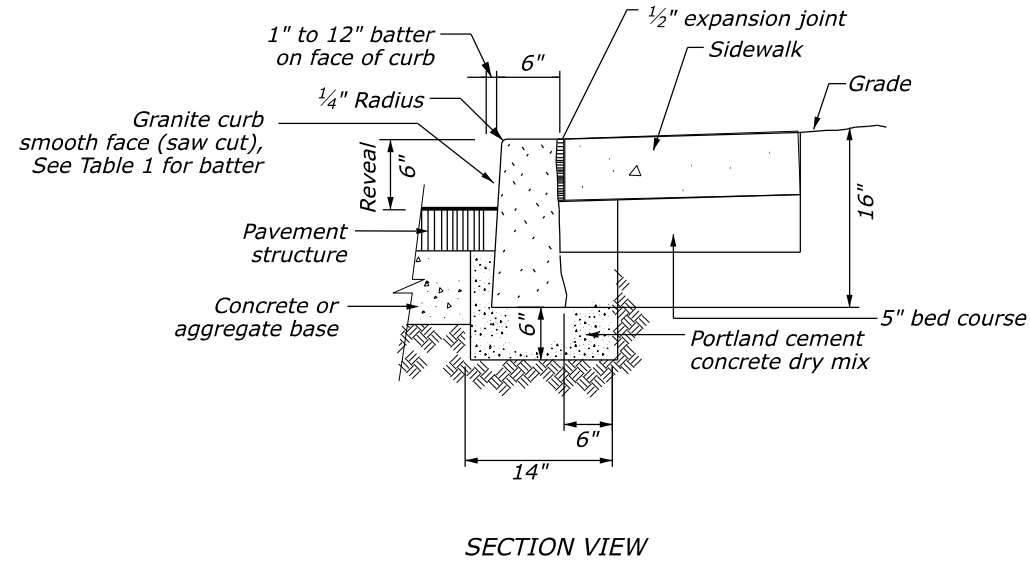

**STONE CURB TYPE 1, 16" DEPTH (GRANITE TYPE A OR B) (WITH SIDEWALK)**

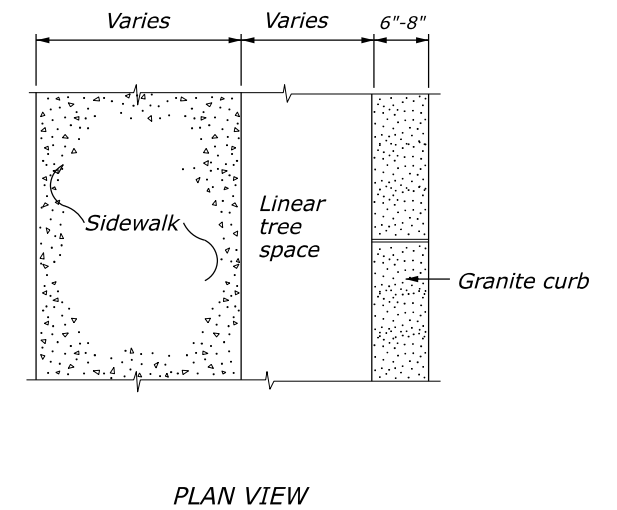

**STONE CURB TYPE 1, 16" DEPTH (GRANITE TYPE A OR B) (WITH SIDEWALK AND LINEAR TREE SPACE)**

**TABLE 1**

BATTER FOR GRANITE CURB	
TYPE	BATTER (H:V)
A	1:12
B	3/4:10

NO SCALE

U.S. DEPARTMENT OF TRANSPORTATION, FHWA OFFICE OF FEDERAL LANDS HIGHWAY	EFLHD DETAIL E609-02
<b>GRANITE CURBS</b>	SPECIFICATION FP-24, FP-14
	APPROVED FOR USE 05/2024