

TYPE - 4A

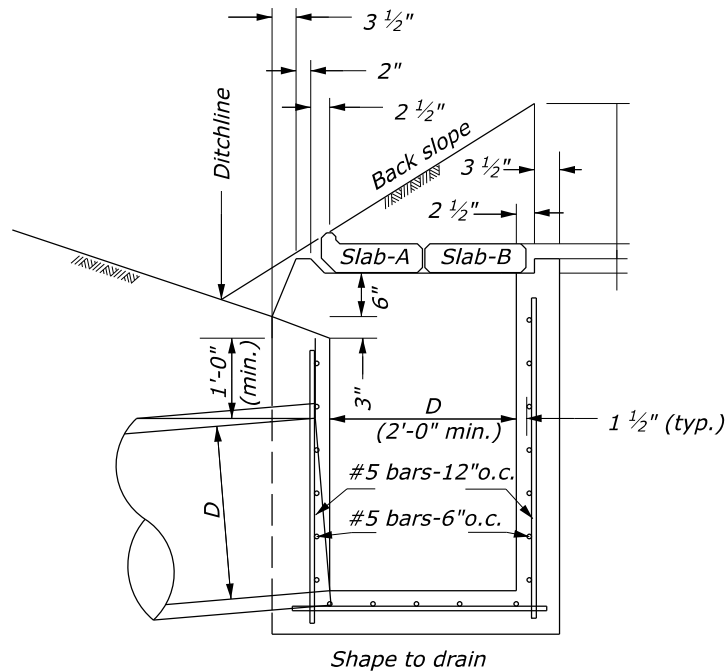

TYPE - 4B

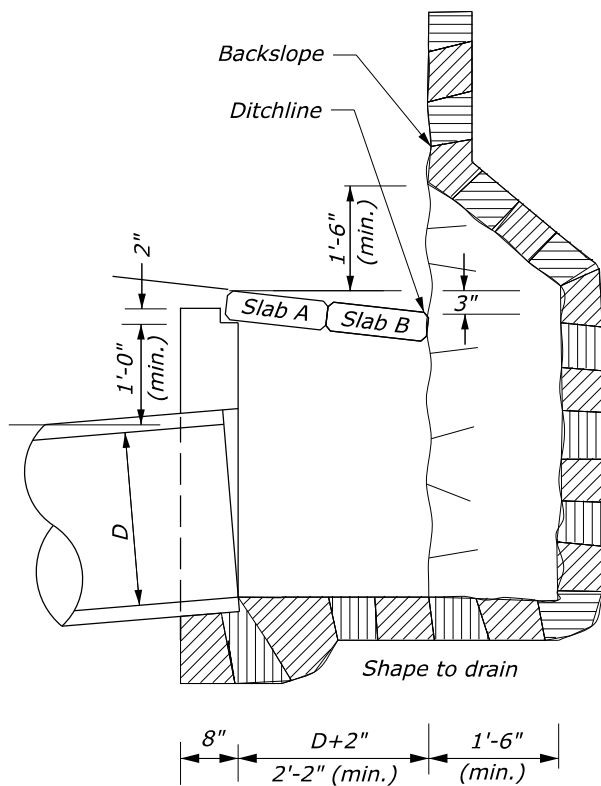

TYPE - 4C
See Note 5

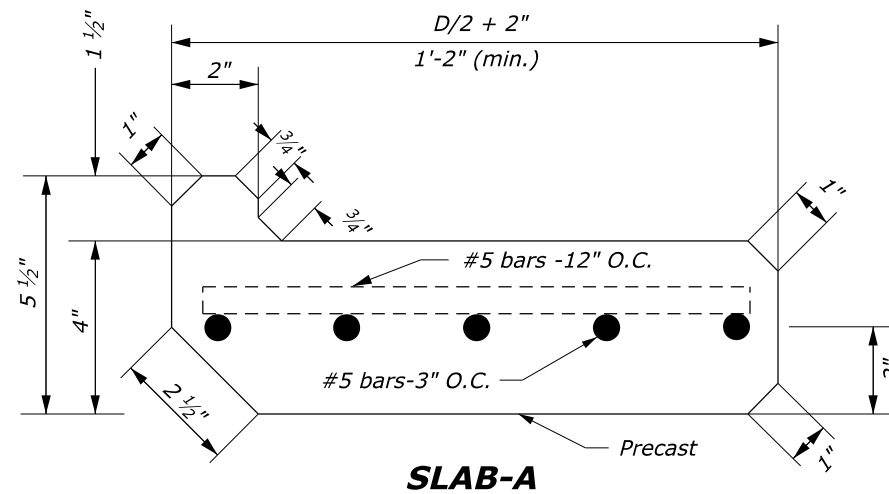

SLAB-A

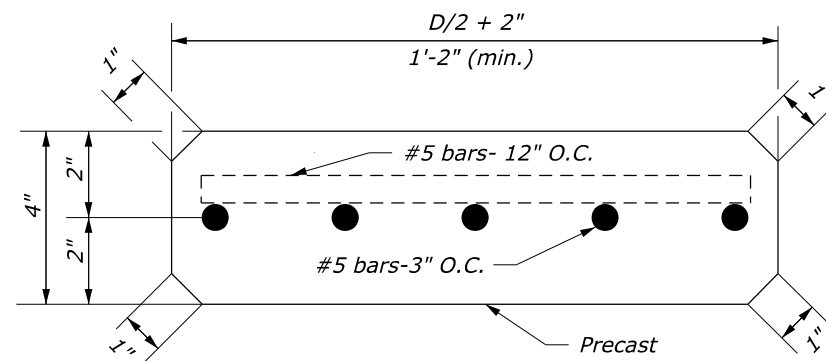

SLAB-B

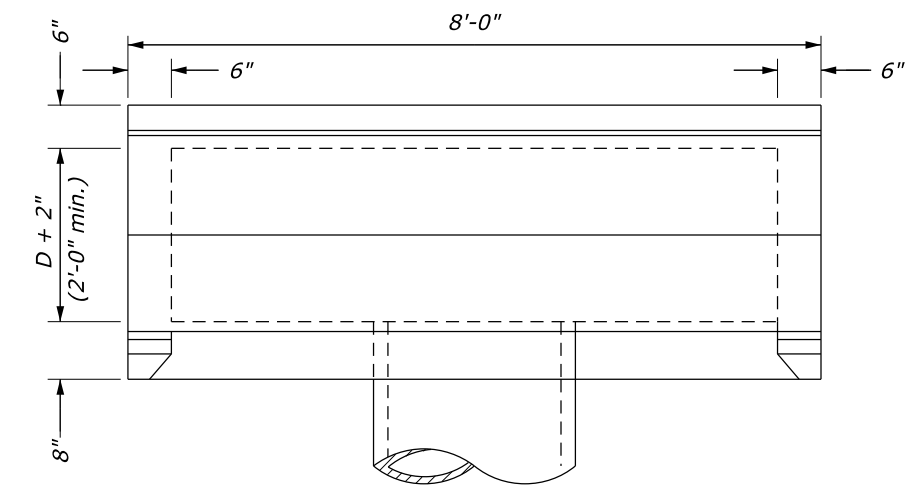

PLAN

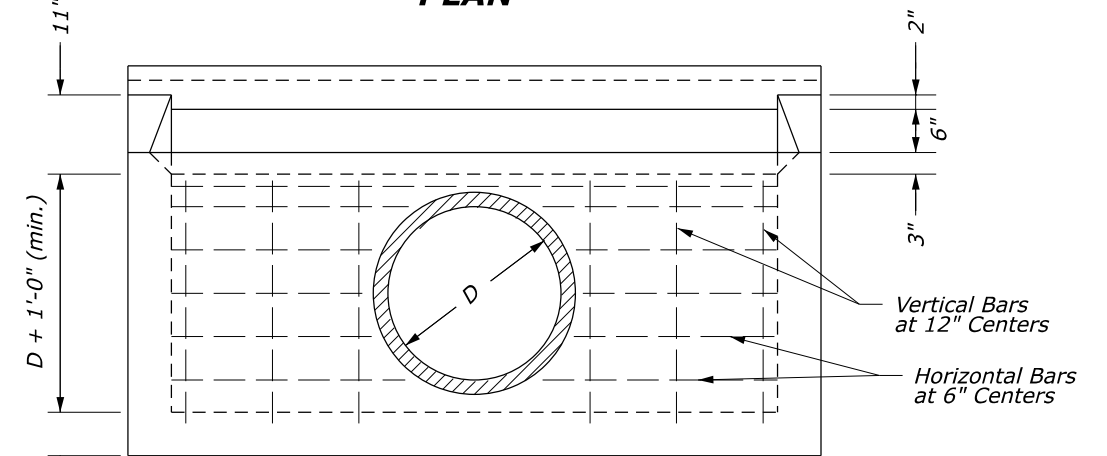

FRONT ELEVATION
(Type 4B shown, other types comparable)

U.S. DEPARTMENT OF TRANSPORTATION, FHWA
OFFICE OF FEDERAL LANDS HIGHWAY

EFLHD DETAIL
E604-01

SPECIFICATION
FP-24, FP-14

APPROVED FOR USE
05/2024

INLET, TYPE 4A, 4B AND 4C

NO SCALE