

NOTES:

1. Prepare cracks for sealing and filling according to Section 414. Follow manufacturer's recommendations for sealing and filling cracks.
2. Force crack repair material into cracks to ensure adhesion to existing surface.
3. See Subsection 414.06 for minimum crack width.
4. Squeegee excess crack sealing and filling material left above the surface. Do not overband cracks.

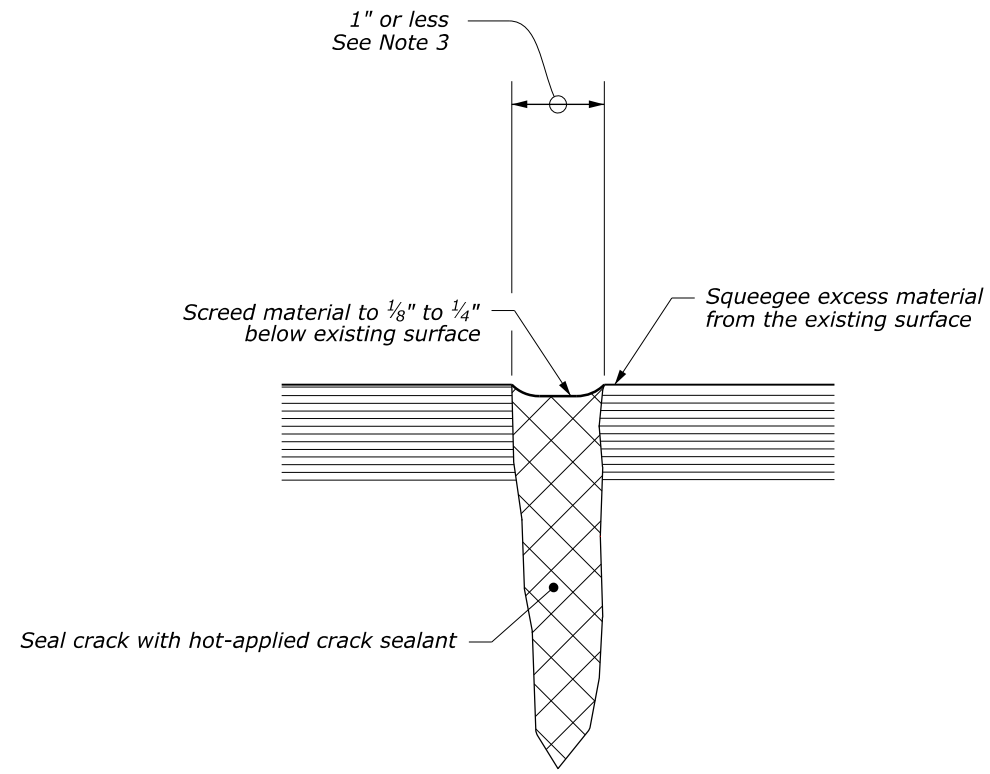

CRACK SEALING

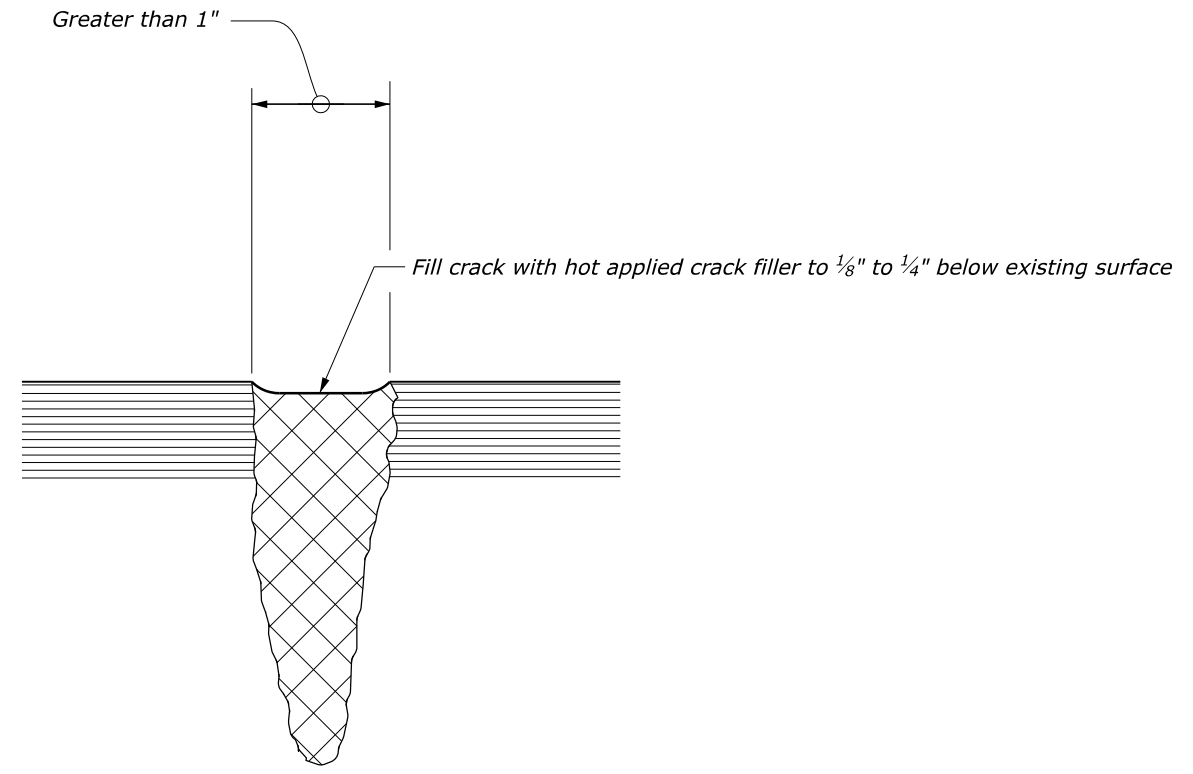

CRACK FILLING

CRACK SEALING AND FILLING

NO SCALE

U.S. DEPARTMENT OF TRANSPORTATION, FHWA OFFICE OF FEDERAL LANDS HIGHWAY		EFLHD DETAIL E414-01
ASPHALT PAVEMENT CRACK SEALING AND FILLING		SPECIFICATION FP-24, FP-14
		APPROVED FOR USE 05/2024

NOTES:

1. Prepare cracks for sealing and filling according to Section 414. Follow manufacturer's recommendations for sealing and filling cracks.
2. Force crack repair material into cracks to ensure adhesion to existing surface.
3. See Subsection 414.06 for minimum crack width.
4. Squeegee excess crack sealing and filling material left above the surface. Do not overband cracks.

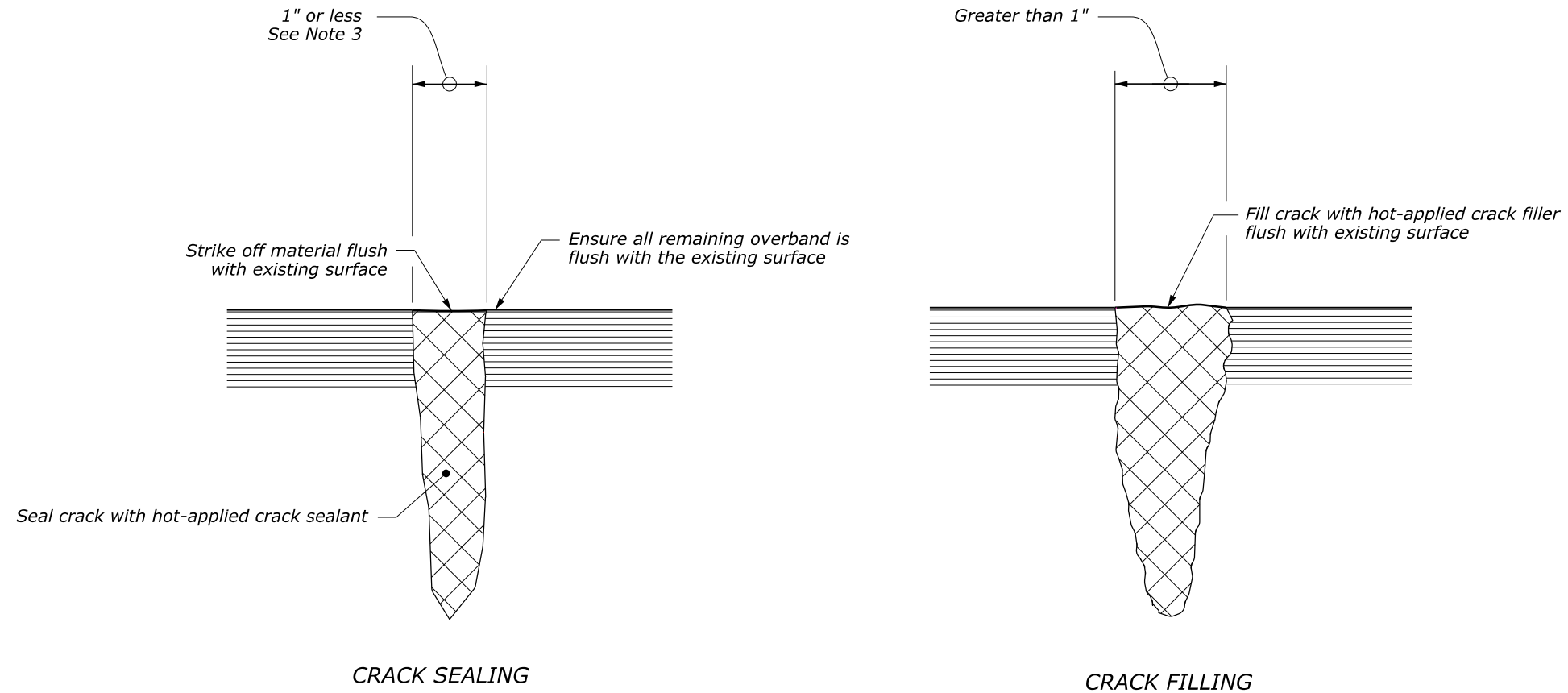

CRACK SEALING AND FILLING

NO SCALE

U.S. DEPARTMENT OF TRANSPORTATION, FHWA OFFICE OF FEDERAL LANDS HIGHWAY		EFLHD DETAIL E414-01
ASPHALT PAVEMENT CRACK SEALING AND FILLING		SPECIFICATION FP-24, FP-14
		APPROVED FOR USE 05/2024