

CULVERT OUTLET WITHOUT DITCH

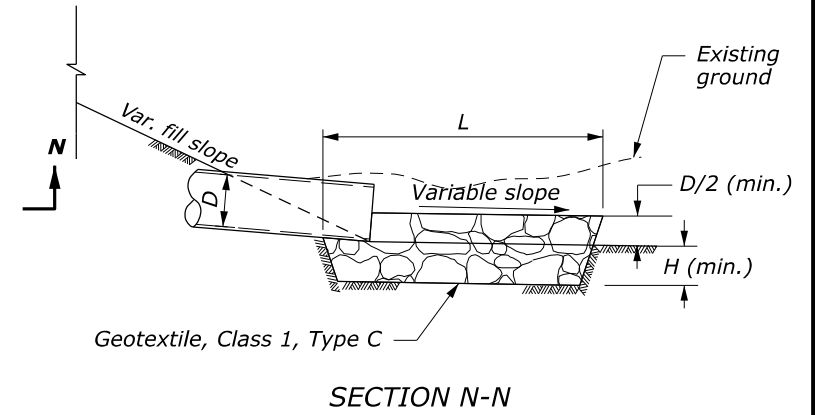
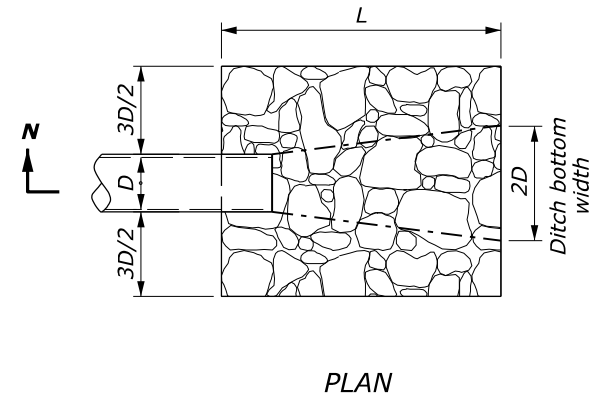

CULVERT OUTLET WITH DITCH

PROTECTIVE APRON AT CULVERT OUTLET WITH NO END TREATMENT

PROTECTIVE APRON DIMENSIONS AND ESTIMATED QUANTITIES

	CULVERT SIZE (D) INCH	RIPRAP CLASS	LENGTH OF APRON (L) FT	DEPTH OF APRON (H) FT	OUTLET WITHOUT DITCH		OUTLET WITH DITCH	
					ESTIMATED RIPRAP QUANTITY CUYD	ESTIMATED GEOTEXTILE QUANTITY SQYD	ESTIMATED RIPRAP QUANTITY CUYD	ESTIMATED GEOTEXTILE QUANTITY SQYD
WITH END SECTION	12	2	4	1.5	1	5	0.9	4
	18	2	6	1.5	2.2	9	2	8
	24	2	8	1.5	3.9	13	3.6	12
	30	3	12.5	2	10.8	27	9.3	24
	36	3	15	2	15.6	37	13.3	32
	42	4	21	2.5	34	63	27.2	52
WITH HEADWALL	12	2	4	1.5	1.6	6	1.1	5
	18	2	6	1.5	3	10	2	8
	24	2	8	1.5	5.3	16	3.6	12
	30	3	12.5	2	15	32	9.3	24
	36	3	15	2	21.7	43	13.3	32
	42	4	21	2.5	47.6	73	27.2	52
WITH HEADWALL AND WINGWALL	12	2	4	1.5	1.6	6	1.1	6.3
	18	2	6	1.5	3	10	2.5	11.1
	24	2	8	1.5	5.3	16	4.5	17
	30	3	12.5	2	15	32	11.6	32
	36	3	15	2	21.7	43	16.7	42.6
	42	4	21	2.5	47.6	73	34.1	68.4
WITH NO END TREATMENT	12	2	6	1.5	1.7	7	1.3	6
	18	2	8	1.5	3.2	12	2.7	10
	24	2	10	1.5	5.2	17	4.4	15
	30	3	14.5	2	13.2	32	10.7	27
	36	3	17	2	18.5	42	15.1	36
	42	4	23	2.5	38.7	70	29.8	56
	48	4	26	2.5	49.8	86	38.5	70

NOTES:

1. Use for aprons serving culverts with slopes of less than 10%.
2. For arch or elliptical pipes, use equivalent diameter for (D) dimension.

NO SCALE

U.S. DEPARTMENT OF TRANSPORTATION, FHWA OFFICE OF FEDERAL LANDS HIGHWAY	EFLHD DETAIL E251-01
PLACED RIPRAP AT CULVERT OUTLETS	SPECIFICATION FP-14
Sheet 2 of 2	APPROVED FOR USE 05/2024