

Notes to the Designer

Updated June 2024

Check Dam

NOTE: DO NOT USE THIS DRAWING IF PAYING BY THE LPSM. This drawing should only be included in the plan set if items are being paid for separately.

General Information

- Printing should be done from the **[Sheet]** View model

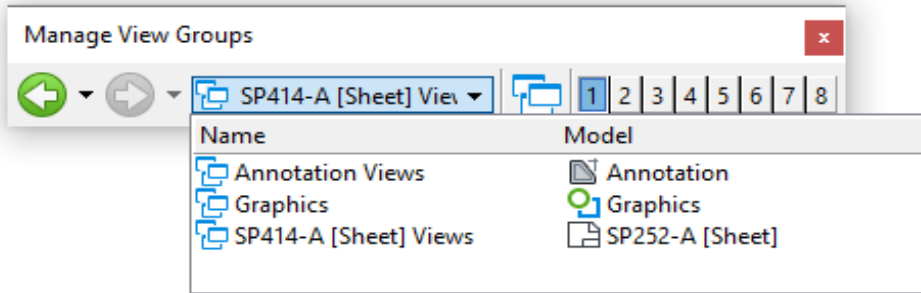

- Appropriate Applications

Check dams reduce scour in a channel or ditch and provide runoff treatment by reducing flow velocity and encouraging sediment deposition. Appropriate applications include:

- Use riprap check dams in conjunction with RECP lining in ditches steeper than 5% or 6%
- Steep channels where storm water runoff velocities exceed 3 ft/s
- During the establishment of grass linings in ditches

- Limitations

Not used in live streams

Drainage areas 10 acres or less

- Limitations

Install the first check dam about 15 ft from the outfall and at regular intervals based on slope gradient and soil type (steeper slopes and more erosive soils (e.g. loose sand or silt) will require shorter spacing between check dams).

When installing a series of check dams in a channel, install outlet stabilization measures below the final dam, such as riprap or geotextile, to minimize erosion potential.

The type of RECP to use is site-specific. Coordinate with Hydraulics to select the type of RECP.

Applicable SCRs

- None

Typical Pay Item Used

- 15706-0200 Soil erosion control, check dam [EA]
- 62901-[0100 through 1700] Rolled erosion control product, type XX [SQYD] or
- 62901-[0100 through 1700] Rolled erosion control product, type XX [ACRE]

Updates

- **September 2020**
 - Updated for OpenRoads Designer
- **June 2024**
 - Updated for FP24

NOTE:

1. Repair all rills and gullies and properly compact before installation.
2. Install check dams in ditches perpendicular to the flowline.
3. Adjust check dam spacing based on site-specific conditions.
4. Furnish rolled erosion control product according to Subsection 713.17.

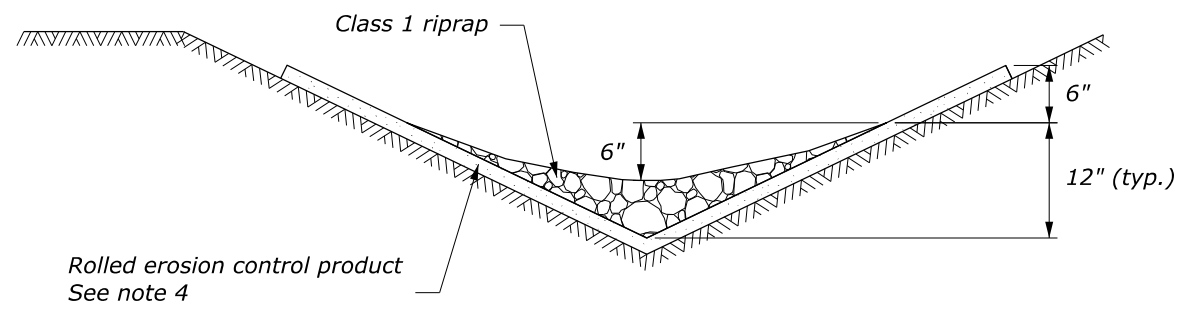

CROSS SECTION
V DITCH

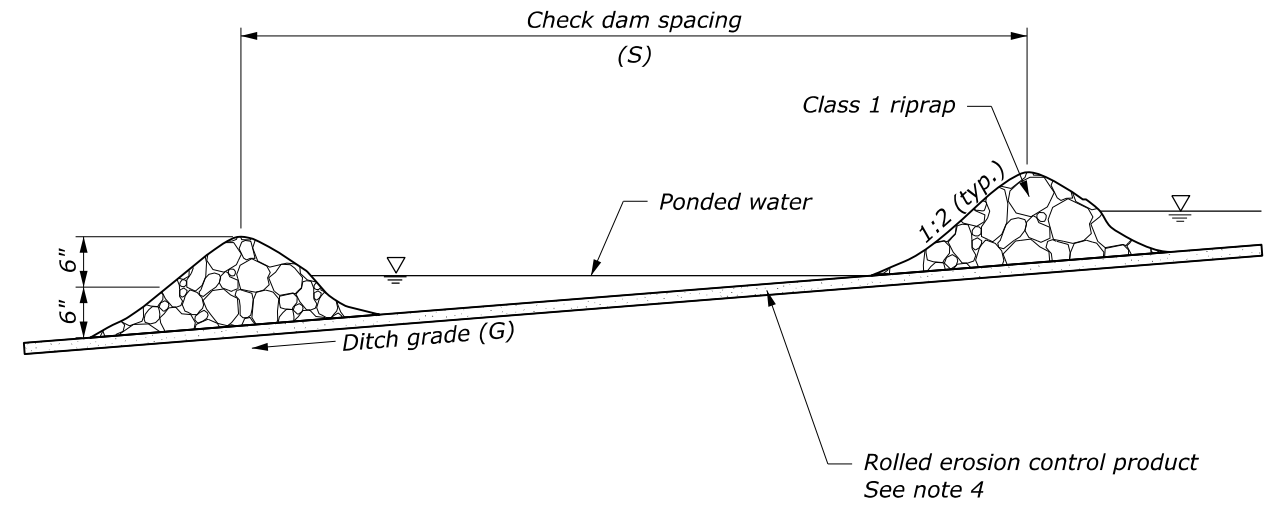

PROFILE VIEW

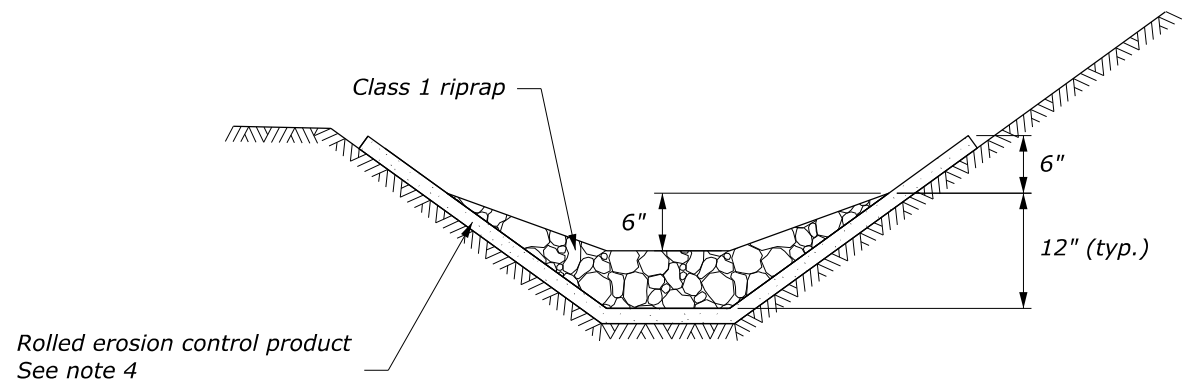

CROSS SECTION
FLAT BOTTOM DITCH

RIPRAP CHECK DAM SPACING
(See note 3)

DITCH GRADE (G)	MAXIMUM CHECK DAM SPACING (S) (ft)
7%	40
8% and 9%	30
≥ 10%	20

**RIPRAP CHECK DAM
WITH ROLLED EROSION CONTROL PRODUCT**

NO SCALE

U.S. DEPARTMENT OF TRANSPORTATION, FHWA OFFICE OF FEDERAL LANDS HIGHWAY	CFLHD DETAIL C157-54
CHECK DAM WITH ROLLED EROSION CONTROL PRODUCT	SPECIFICATION FP-24, FP-14
	APPROVED FOR USE
	DRAFT: 06/2024