

# EARTHWORK REPRESENTATION: GRADING SUMMARIES & MASS HAUL DIAGRAMS

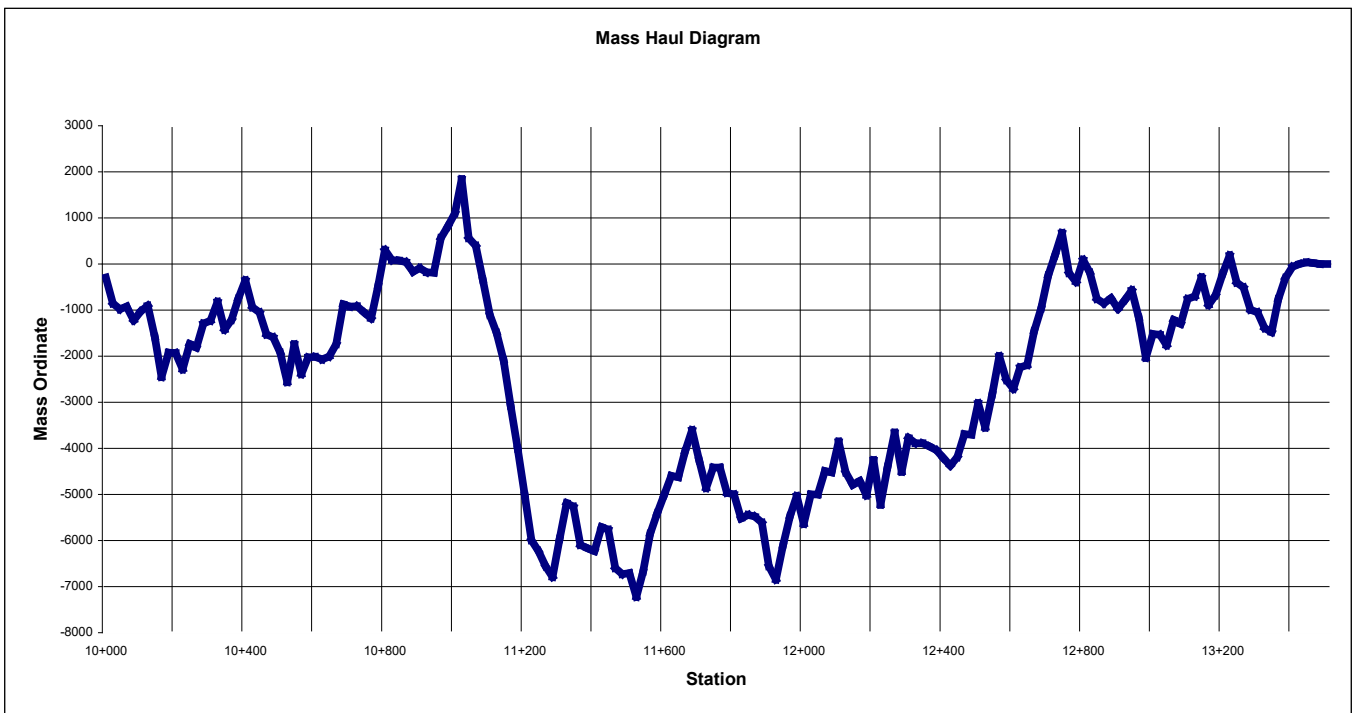

## TABLE OF CONTENTS

<b>INTRODUCTION .....</b>	<b>2</b>
<b>EARTHWORK CONSIDERATIONS .....</b>	<b>2</b>
<b>GRADING SUMMARY SPREADSHEET .....</b>	<b>2</b>
TABLE 1: SUMMARY OF EXCAVATION VOLUMES.....	4
TABLE 2: SUMMARY OF EMBANKMENT VOLUMES.....	8
TABLE 3: EARTHWORK CALCULATIONS .....	14
<b>GRADING SUMMARY .....</b>	<b>15</b>
TABLE 4: SELECTION OF EARTHWORK PAY ITEMS .....	17
<b>EARTHWORK REPRESENTATION DIAGRAMS.....</b>	<b>18</b>
<b>MASS HAUL DIAGRAM .....</b>	<b>28</b>
<b>FINAL THOUGHTS .....</b>	<b>28</b>

## Introduction

This document provides a guide to the Central Federal Lands standard procedure for calculating and representing earthwork volumes in the plans. Typically, earthwork representation in the plans includes the Grading Summary and cross sections. On larger jobs a Mass Haul Diagram will be included. This guide applies to both internal designers and A/E consultants.

Earthwork operations represent an area of substantial risk to contractors. In CFLHD contracts, the risk is typically associated with one to four pay items, with Pay Item 20401-0000, Roadway excavation, generally being the primary payment item. Under this pay item, the contractor must anticipate and price the work associated with excavation, haul, embankment, benching, adding or subtracting moisture from soils, finishing, and other associated operations. Estimating costs is further complicated by:

- The type and variation in the materials to be excavated (rock, clay, soil);
- If blasting is required and how much;
- The type of equipment to be used in excavating and hauling material;
- If the haul is primarily uphill or downhill;
- Coordination of earthwork operations with other installations (walls, culverts, underdrains, etc.);
- Weather considerations; and
- Impacts of materials testing.

When representing earthwork, the focus is on prism excavation and embankment, added excavation and embankment quantities, quantities unavailable for embankment, and other details related to the construction of a project to design subgrade elevation.

Refer to the [CFLHD Earthwork Representation Template Drawings \(FP14 Version\)](#) for a visual representation of the earthwork quantities.

## Earthwork Considerations

The earthwork representation of the work can only be as good as the information upon which the design assumptions are based. Before performing detailed earthwork calculations, consider the following items:

- Coordinate with the Geotechnical Engineer while developing the Grading Summary. There are inherent difficulties in earthwork estimation, and the Geotechnical Engineer can provide valuable insight into difficult terrain issues, engineering properties of different geologic units and soil types, and the impact that small or large fills can have on shrink/swell. Incorporate recommendations from the Geotechnical Report, including shrink/swell, topsoil stripping depth, and backfill material anticipated to be available from on-site excavation.
- Coordinate with the Pavements Engineer to determine locations and depths of subexcavation.
- Coordinate with Surveys to obtain the appropriate level of accuracy in topographic surveys.
- Coordinate with Construction to better understand constructability issues related to earthwork.
- Avoid sliver cuts and fills.

## Grading Summary Spreadsheet

The Grading tab is a worksheet in the [Grading Summary spreadsheet \(FP14 Version\)](#) currently in use at CFLHD. The worksheet includes named boundary stationing and the corresponding earthwork quantities. The worksheet includes quantities imported directly from ORD and quantities hand-calculated by the user.

### ***Excavation Volumes***

Table 1 below represents the excavation volumes in the summary.

### ***Embankment Volumes***

Table 2 represents the embankment volumes in the summary.

Typically, only wall backfill quantities shown in the worksheet are anticipated to be generated from on-site excavation. By including quantities in the Grading Summary, the designer is representing that material excavated or found on-site WILL meet the gradations and material quality requirements according to the FP and SCRs. Coordinate with the Cross Functional Team (CFT); make sure that materials tests are performed to verify this requirement. Do not assume the material will meet the specifications.

**If wall backfill material will be imported from off-site, do not show the quantities in the worksheet.**

### ***Earthwork Calculations***

Calculations for added and subtracted earthwork quantities occur on this worksheet. In addition, calculations for pay item quantities occur on this worksheet.

See Table 3 for a summary of earthwork calculations that occur on this worksheet.

**Table 1: Summary of Excavation Volumes**

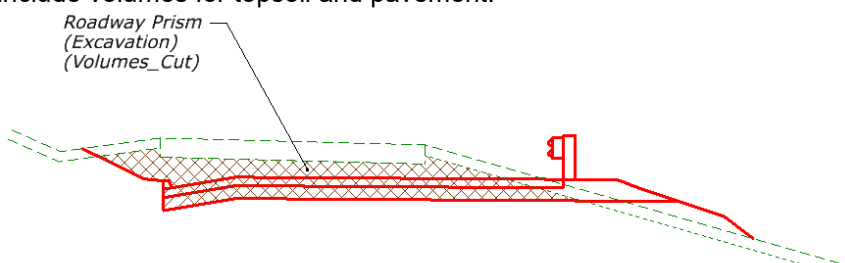
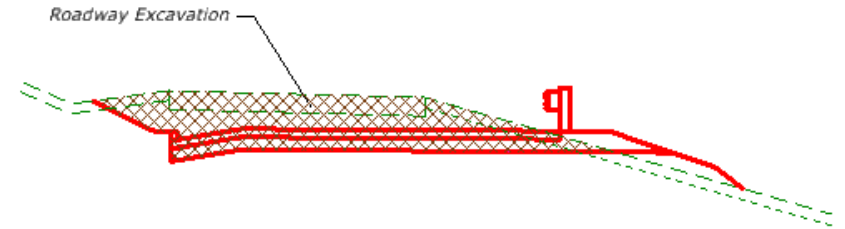
Column in Grading	Description	How is Quantity Calculated?	Remarks
C	Roadway Prism Excavation (roadway prism minus topsoil and pavement) (Volumes_Cut)	ORD	<ul style="list-style-type: none"> <li>Unadjusted volumes (the numbers do not account for shrink or swell); This number does not include volumes for topsoil and pavement.</li> </ul> 
D	Total Excavation Volumes_Cut+Existing_Payment (not replaced) +Topsoil	Calculated on spreadsheet	<ul style="list-style-type: none"> <li>Unadjusted volumes including volumes for existing pavement and topsoil</li> </ul> 
E	Approach Road Excavation	ORD or User Calculated (Must be Input by User)	<ul style="list-style-type: none"> <li>Input excavation volumes under the mainline stationing that best represents the approach road location. By doing so, if a Mass Haul Diagram is necessary it will better reflect the anticipated haul of material.</li> <li>If the approach road length is excessive, the volumes can be tabulated in a separate Grading Summary or at the bottom of the mainline summary. If values are tabulated at the bottom of the mainline summary, be sure NOT to include the quantities in the Mass Haul Diagram.</li> </ul>
F (Pay Column)	Roadway Excavation	Calculated on spreadsheet	<ul style="list-style-type: none"> <li>Total unadjusted excavation for total excavation for the mainline and approach roads.</li> <li>If roadway excavation is used as a pay item, the quantity in this column is the plan quantity.</li> </ul>

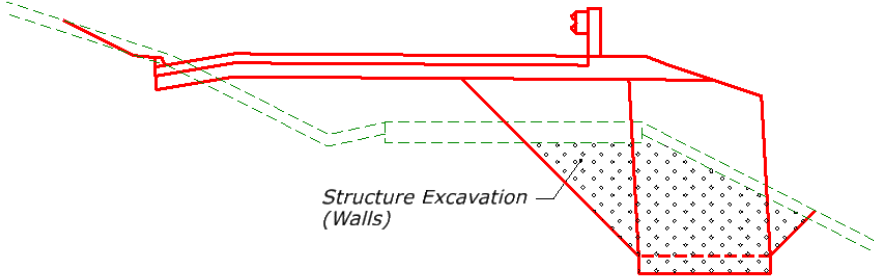
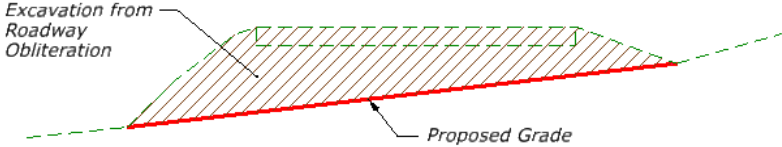
Column in Grading	Description	How is Quantity Calculated?	Remarks
G	(+) Structure Excavation (Walls)	ORD	<ul style="list-style-type: none"> <li>▪ Volume of material displaced by retaining walls and associated backfill below original ground of the existing roadway.</li> <li>▪ Walls that typically have this earthwork quantity include:               <ul style="list-style-type: none"> <li>▪ Mechanically-stabilized earth (MSE) wall</li> <li>▪ Concrete cut and fill walls</li> <li>▪ Soil nail wall</li> <li>▪ Rockery</li> <li>▪ Guardwall</li> <li>▪ Shored mechanically-stabilized earth (SMSE) wall</li> <li>▪ Gabion faced mechanically-stabilized earth (GFMSE) wall</li> </ul> </li> </ul>  <p>Additional wall diagrams shown on sheets 20-27.</p>
H	(+) Excavation from Roadway Obliteration	User Calculated (Must be Input by User)	<ul style="list-style-type: none"> <li>▪ Volume of excavation from an obliterated area located outside the project slope stake limits.</li> <li>▪ Input excavation volumes under the mainline stationing that best represents the obliteration location.</li> <li>▪ If the roadway obliteration is a significant distance from mainline (e.g. 1000' or more), add these volumes on a separate row at the bottom of the Grading Summary. Do NOT include in the Mass Haul Diagram.</li> <li>▪ Typically, excavation for roadway obliteration is not paid for under Section 204. Roadway obliteration is paid under Section 211 and is measured as an area. The obliteration area should be calculated separately and shown in the Miscellaneous Summaries.</li> </ul> 
I	(+) Subexcavation (Subex_Exc2)	ORD or User Calculated	<ul style="list-style-type: none"> <li>▪ Volume of subexcavated material</li> <li>▪ Use Column L also if this material is unsuitable for fill</li> </ul>

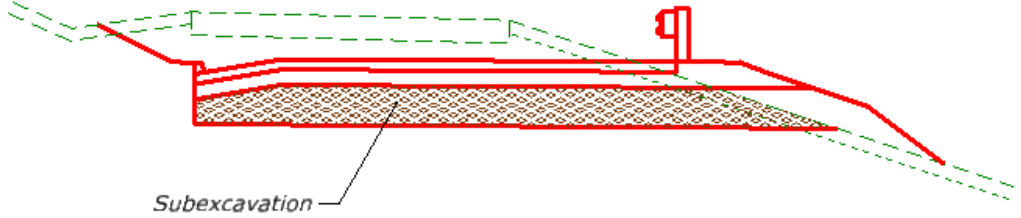
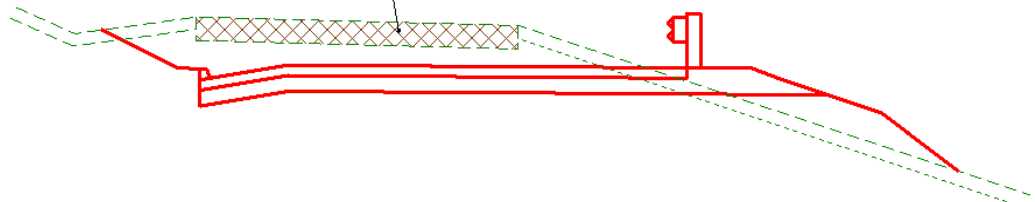
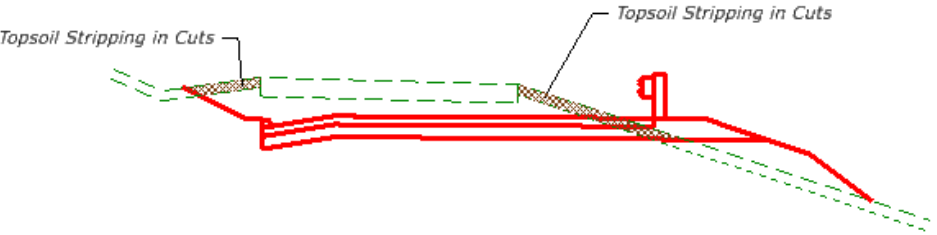
Column in Grading	Description	How is Quantity Calculated?	Remarks
			
J	(-) Pavement Removal in Cuts (Exist Pvmt Layer1 (removed))	ORD	<ul style="list-style-type: none"> <li>▪ Volume of pavement removed in cuts</li> <li>▪ Quantity included only if existing pavement will not be used in fills (e.g., existing pavement recycled for base course or hauled off project).</li> <li>▪ If the project will incorporate the existing pavement as fill material, do not use this column.</li> </ul> 
K	(-) Topsoil Stripping in Cuts (Exist Topsoil (removed))	ORD	<ul style="list-style-type: none"> <li>▪ Volume of topsoil conserved from cuts</li> <li>▪ Use the depth of topsoil stripping recommended in Geotechnical Report</li> </ul> 
L	(-) Disposal of Subex (Subex_Exc2)	ORD or User Calculated	<ul style="list-style-type: none"> <li>▪ Volume of subexcavation wasted offsite</li> <li>▪ If subexcavated material can be used for embankment, do not use this column. (This is extremely rare)</li> </ul>

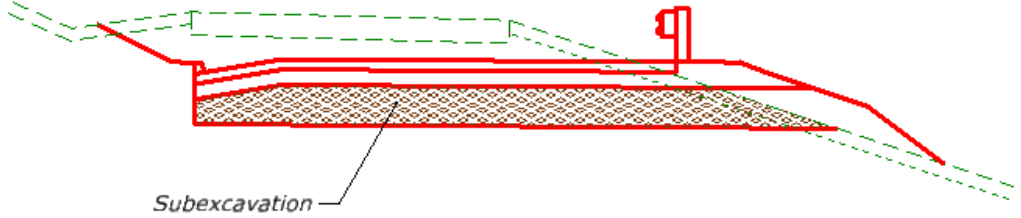
Column in Grading	Description	How is Quantity Calculated?	Remarks
			
M	Shrink/Swell Factor	Input by User on Manual Input worksheet	<ul style="list-style-type: none"> <li>▪ Shrink/swell factors are used to adjust quantities from the bank (BCY (BCM)) state to the compacted (CCY (CCM)) state.</li> <li>▪ Use the shrink/swell recommended in the Geotechnical Report.</li> <li>▪ Swell factors (values greater than one) are typically associated with rocky materials and mean that the compacted volume will be greater than the bank volume.</li> <li>▪ Shrink factors (values less than one) are typically associated with clayey or granular materials and mean that the compacted volume will be less than the bank volume.</li> </ul>
N	Total Excavation Available for Fills	Calculated on spreadsheet	<ul style="list-style-type: none"> <li>▪ Total <i>adjusted</i> excavation for the specified station (quantities have been adjusted by estimated shrink/swell factors)</li> </ul>

**Table 2: Summary of Embankment Volumes**

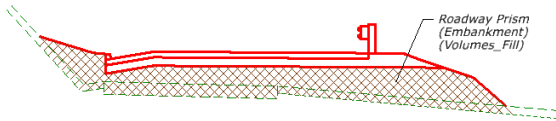
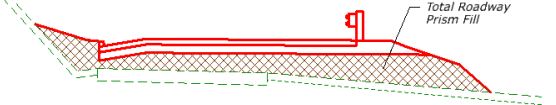
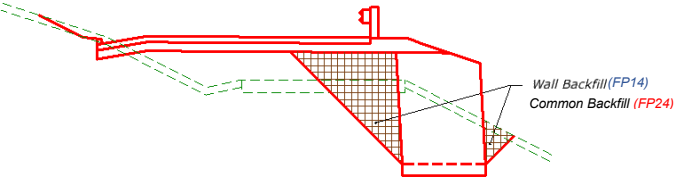
Column in Grading	Description	How is Quantity Calculated?	Remarks
O	Roadway Prism Embankment (Volume_Fills)	ORD	<ul style="list-style-type: none"> <li>▪ Unadjusted volumes calculated directly by ORD. Includes volumes for topsoil and existing pavement backfill.</li> </ul> 
P	Total Roadway Prism Fill	Calculated on spreadsheet	<ul style="list-style-type: none"> <li>▪ Total embankment needed for the specified named boundary. Volumes for topsoil and existing pavement backfill are removed from this column.</li> </ul> 
Q	Approach Road Embankment	ORD or User Calculated (Must be Inputed by User)	<ul style="list-style-type: none"> <li>▪ Input the approach road embankment volumes under the mainline stationing that best represents the approach road location.</li> <li>▪ If the approach road length is excessive, the volumes can be tabulated in a separate Grading Summary or at the bottom of the mainline summary. If they are tabulated at the bottom of the mainline summary, be sure NOT to include the tabulations in the Mass Haul Diagram</li> </ul>
R (Pay Column)	Total Roadway Prism Fill for pay	Calculated on spreadsheet	<ul style="list-style-type: none"> <li>▪ Sum of the quantities in columns P and Q.</li> <li>▪ If embankment construction is used as a pay item, the quantity in this Column is the plan quantity.</li> </ul>
S	(+) Common Backfill (FP24) Wall Backfill (FP14)	ORD	<ul style="list-style-type: none"> <li>▪ Assumes on-site material can meet requirements of Subsection 704.01 (FP24) or 704.03(a) (FP14).</li> <li>▪ Walls that typically have this earthwork quantity include:                             <ul style="list-style-type: none"> <li>▪ MSE wall</li> <li>▪ SMSE wall</li> <li>▪ Rockery</li> <li>▪ Concrete retaining wall with parapet</li> </ul> </li> </ul> 

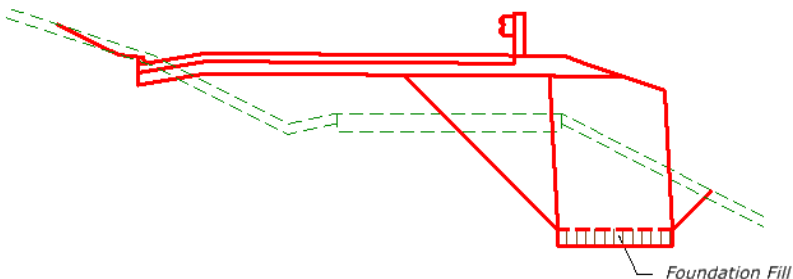
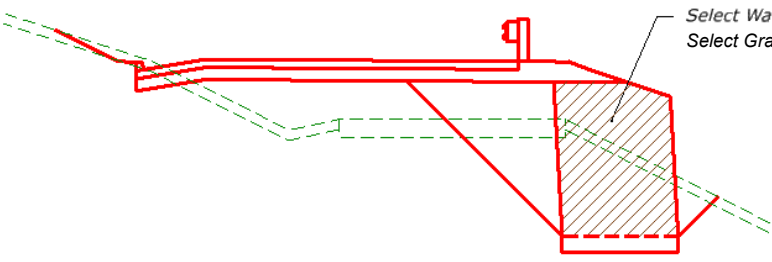
Column in Grading	Description	How is Quantity Calculated?	Remarks
T	(+) Foundation Fill	ORD	<ul style="list-style-type: none"> <li>▪ Assumes on-site material can meet requirements of Subsection 704.01.</li> <li>▪ If foundation fill will be imported from off-site, do not use this column to show the quantities.</li> <li>▪ Walls that typically have this earthwork quantity include:               <ul style="list-style-type: none"> <li>▪ MSE wall</li> <li>▪ SMSE wall</li> <li>▪ Rockery</li> <li>▪ Guardwall</li> <li>▪ Concrete cut wall</li> <li>▪ Concrete retaining wall with parapet</li> <li>▪ Concrete fill wall</li> </ul> </li> </ul> 
U	(+) Select Granular Backfill (FP24) Select Wall Backfill (FP14) (MSE Wall Backfill 2:) (MSE Wall Backfill 2:)	ORD	<ul style="list-style-type: none"> <li>▪ Assumes on-site material can meet requirements of Subsection 704.08 (FP24) or 704.08 (FP14).</li> <li>▪ If select wall backfill will be imported from off-site, do not use this column to show the quantities.</li> <li>▪ Walls that typically have this earthwork quantity include:               <ul style="list-style-type: none"> <li>▪ MSE wall</li> <li>▪ SMSE wall</li> <li>▪ GFMSE wall</li> </ul> </li> </ul> 
V	(+) Rock (Rockery Wall Backfill 2:) (Rockery Wall Backfill 2:)	ORD	<ul style="list-style-type: none"> <li>▪ Assumes on-site material can meet requirements of Subsection 705.06.</li> <li>▪ If rockery rocks will be imported from off-site, do not use this column to show the quantities.</li> <li>▪ Walls that typically have this earthwork quantity include:               <ul style="list-style-type: none"> <li>▪ Rockery</li> </ul> </li> </ul>

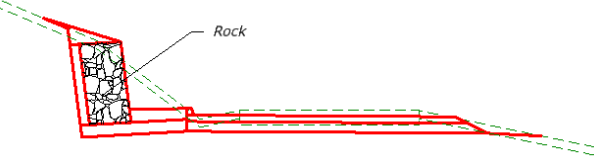
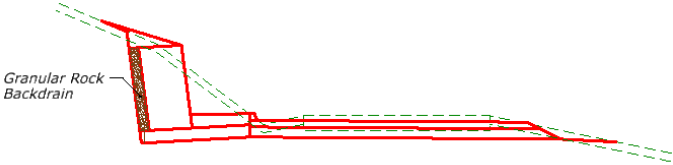
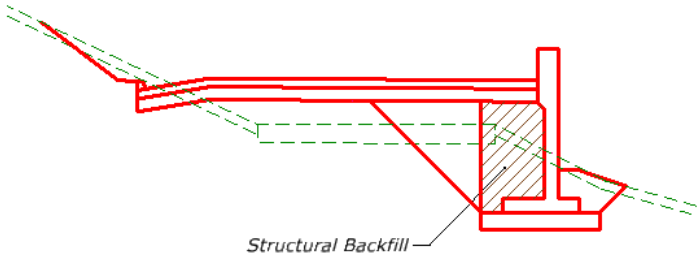
Column in Grading	Description	How is Quantity Calculated?	Remarks
			
W	(+) Granular Rock Backdrain (Rockery Wall Back:)	ORD	<ul style="list-style-type: none"> <li>▪ Assumes on-site material can meet requirements of Subsection 703.03(a).</li> <li>▪ If granular rock backdrain will be imported from off-site, do not use this column to show the quantities</li> <li>▪ Walls that typically have this earthwork quantity include:               <ul style="list-style-type: none"> <li>▪ Rockery</li> </ul> </li> </ul> 
X	(+) Structural Backfill (Wall Backfill 2:)	ORD	<ul style="list-style-type: none"> <li>▪ Assumes on-site material can meet requirements of Subsection 704.01 (FP24) or 704.04 (FP14).</li> <li>▪ If structural backfill material is imported from off-site, do not show any quantities in this column.</li> <li>▪ Walls that typically have this earthwork quantity include:               <ul style="list-style-type: none"> <li>▪ Concrete cut wall</li> <li>▪ Concrete retaining wall with parapet</li> <li>▪ Concrete fill wall</li> </ul> </li> </ul> 
Y	(+) <b>Common Backfill (FP24)</b> <b>Backfill Material (FP14)</b> (Guard Wall Backfill 1 Wall Backfill Top Soil Nail Wall)	ORD	<ul style="list-style-type: none"> <li>▪ Assumes on-site material can meet requirements of Subsection 704.01 (FP24) or 704.03 (FP14).</li> <li>▪ If backfill material will be imported from off-site, do not use this column to show the quantities</li> <li>▪ Walls that typically have this earthwork quantity include:               <ul style="list-style-type: none"> <li>▪ Guardwall</li> <li>▪ Concrete retaining wall with parapet</li> <li>▪ Soil nail wall</li> </ul> </li> </ul>

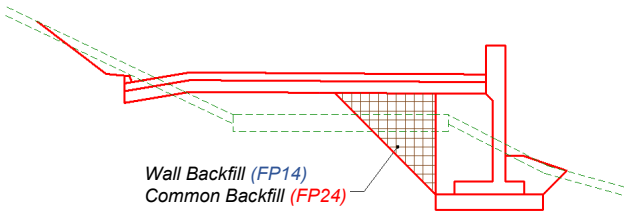
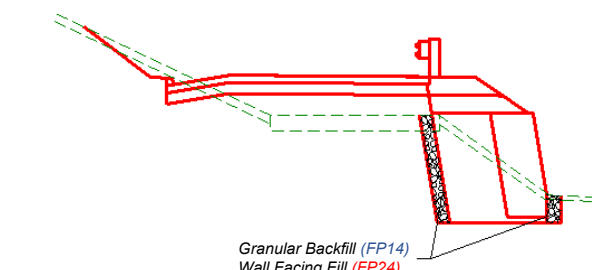
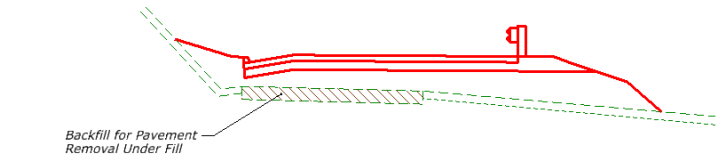
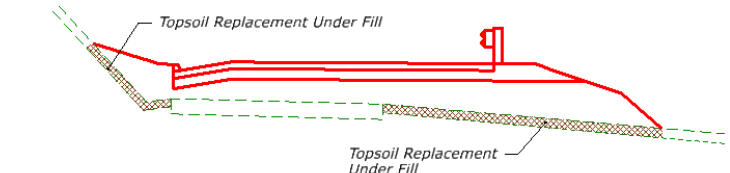
Column in Grading	Description	How is Quantity Calculated?	Remarks
	Backfill)		 <p>Wall Backfill (FP14) Common Backfill (FP24)</p>
Z	(+) Granular Backfill (FP14) Wall Facing Fill (FP24) (MSE Wall Backfill 1 Rockery Wall Backfill 2)	ORD	<ul style="list-style-type: none"> <li>▪ Assumes on-site material can meet requirements of Subsection 704.01 (FP24) or 704.03 (FP14).</li> <li>▪ If granular backfill will be imported from off-site, do not use this column to show the quantities.</li> <li>▪ Walls that typically have this earthwork quantity include:               <ul style="list-style-type: none"> <li>▪ GFMSE wall</li> </ul> </li> </ul>  <p>Granular Backfill (FP14) Wall Facing Fill (FP24)</p>
AA	(+) Backfill for pavement removal under fill (Exist Pvmt Layer 1 (removed and replaced):)	ORD	<ul style="list-style-type: none"> <li>▪ Quantity included only if existing pavement will not be used in fills (e.g., existing pavement recycled for base course or hauled off project)</li> <li>▪ Volume of material needed to backfill the existing pavement area.</li> <li>▪ If the project will incorporate the existing pavement as fill material, do not use this column.</li> </ul>  <p>Backfill for Pavement Removal Under Fill</p>
AB	(+) Topsoil replacement under fill (Exist Topsoil (removed and replaced):)	ORD	<ul style="list-style-type: none"> <li>▪ Volume of fill material needed to replace topsoil conserved under new fills of the roadway.</li> </ul>  <p>Topsoil Replacement Under Fill</p>

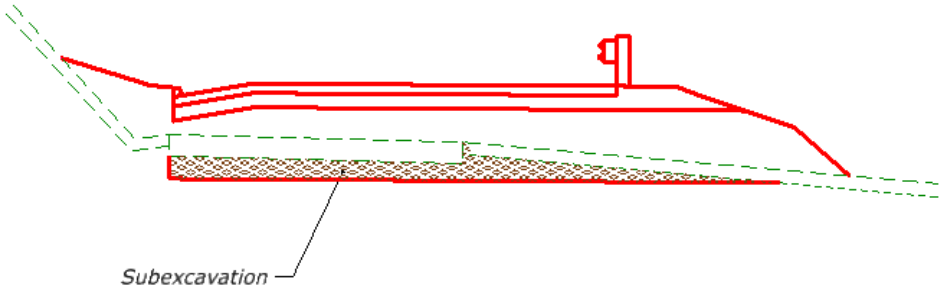
Column in Grading	Description	How is Quantity Calculated?	Remarks
AC	(+) Subexcavation (Subex_Backfill1:)	ORD or User Calculated	<ul style="list-style-type: none"> <li>Typically, this column should have the same quantities identified in Column H (Subexcavation).</li> <li>In cases where material will be subexcavated and recompacted in place, Columns H and AA still need to have the same value because subexcavated material will typically experience volume changes once it is excavated and recompacted (note the difference in the definition of material, Column H is bank (BCY (BCM)), while Column AE is compacted (CCY (CCM)).</li> </ul> 
AD	(+) Aggregate Base	ORD or User Calculated	<ul style="list-style-type: none"> <li>Volume of material conserved from roadway excavation and processed for use as aggregate base.</li> <li>Assumes on-site material can meet requirements of Subsection 703.05 or 703.06.</li> <li>If aggregate base will be imported from off-site, do not use this column to show the quantities.</li> </ul>
AE	(+) Riprap	ORD or User Calculated	<ul style="list-style-type: none"> <li>Volume of material conserved from roadway excavation and processed for use as riprap</li> <li>Assumes on-site material can meet requirements of Subsection 705.02.</li> <li>Quantity included only if onsite material will be conserved for riprap.</li> <li>If riprap will be imported from off-site, do not use this column to show the quantities.</li> </ul>
AF	(+) Special Rock Embankment	ORD or User Calculated	<ul style="list-style-type: none"> <li>Volume of material conserved from roadway excavation and processed for use as special rock embankment</li> <li>Assumes on-site material can meet requirements of Subsection 705.04.</li> <li>If material for special rock embankment will be imported from off-site, do not use this column to show the quantities.</li> </ul>
AG	(+) Embankment for Roadway Obliteration	ORD or User Calculated	<ul style="list-style-type: none"> <li>Show quantities in this column for obliteration areas where additional embankment will be needed. If the sections of obliterated roadway are adjacent to the proposed construction, input the embankment quantities in the row with the appropriate station.</li> <li>If the obliterated areas are not nearby the proposed construction, add the quantities in a separate row at the bottom of the Grading Summary. Do not use quantities shown at the bottom of the Grading Summary when making the Mass Haul Diagram, as they will not accurately portray the hauling needs of the project.</li> </ul>

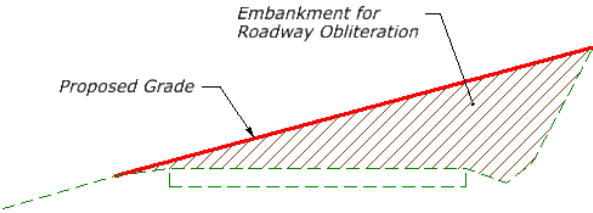
Column in Grading	Description	How is Quantity Calculated?	Remarks
			
AH	(+) Topping	ORD or User Calculated	<ul style="list-style-type: none"> <li>▪ This column represents material conserved from roadway excavation to be used as topping or select topping.</li> <li>▪ Assumes on-site material can meet requirements of Subsection <a href="#">704.01 (FP24)</a> or <a href="#">704.05 (FP14)</a>.</li> <li>▪ If material for topping will be imported from off-site, do not use this column to show the quantities.</li> </ul>
AI	Total Embankment	Calculated on spreadsheet	<ul style="list-style-type: none"> <li>▪ Total volume of material required to construct the embankments in the identified station range.</li> </ul>

**Table 3: Earthwork Calculations**

Column in Grading	Description	How is Quantity Calculated?	Remarks										
AJ	Excavation - Embankment	Calculated on spreadsheet	<ul style="list-style-type: none"> <li>Volume of the surplus or shortage of material at each station.</li> <li>Total Excavation Available for Fills (Column M) minus Total Embankment (Column AG).</li> </ul>										
AK	Waste	Calculated on spreadsheet	<ul style="list-style-type: none"> <li>The value in this column is the same as the value in Column AH (Excavation – Embankment)</li> <li>When all the values in this column are added together, this value represents the volume of waste, or excess material, for the entire project.</li> </ul>										
AL	Embankment Construction	Calculated on spreadsheet	<ul style="list-style-type: none"> <li>The values in the column are the same as the values in Column N (Roadway Prism Embankment) + Column P (Approach Road Embankment) for each row.</li> <li>When all the values in this column are added together, it represents the total prism volume of embankment needed to construct the project.</li> </ul>										
AM	Unclassified Borrow Required	Calculated on spreadsheet	<ul style="list-style-type: none"> <li>The value in this column is the same as those in Column AH (Excavation – Embankment).</li> </ul>										
AN	Unclassified Borrow Shrink/Swell	User Input	<ul style="list-style-type: none"> <li>Unclassified borrow is measured in the field in its original position, so the material needs to be in bank state. (See Subsection 204.16(b).) An estimated shrink/swell of the borrow material must be applied to the compacted volumes to get from compacted state to bank state.</li> <li>A common estimated shrink/swell for unclassified borrow is 0.9.</li> </ul>										
AO	Unclassified Borrow	Calculated on spreadsheet	<ul style="list-style-type: none"> <li>This column is associated with Pay Item 20403-0000, Unclassified borrow.</li> <li>Divide Column AK (Unclassified Borrow Required) by Column AL (Unclassified Borrow Shrink/Swell).</li> <li>When the values in this column are totaled at the bottom of the summary, the resulting value is the total volume of unclassified borrow needed to build the embankments for the entire project.</li> </ul>										
AP	Mass Ordinate	Calculated on spreadsheet	<ul style="list-style-type: none"> <li>This column represents the cumulative mass differential as the project moves from the start through the end. The values in this column are best shown through the use of an example table: <table border="1" data-bbox="898 993 1621 1187"> <thead> <tr> <th>Excavation – Embankment</th> <th>Mass Ordinate</th> </tr> </thead> <tbody> <tr> <td>-518</td> <td><b>-518</b></td> </tr> <tr> <td>1169</td> <td><math>(-518 + 1169) = \mathbf{651}</math></td> </tr> <tr> <td>2451</td> <td><math>(651 + 2451) = \mathbf{3102}</math></td> </tr> <tr> <td>-1822</td> <td><math>(3102 + -1822) = \mathbf{1280}</math></td> </tr> </tbody> </table> </li> <li>The mass ordinate for the first row of the Grading Summary is always identical to the Excavation – Embankment value. To obtain subsequent mass ordinate values, add the mass ordinate in the row above to the Excavation – Embankment value in the row you are working in.</li> </ul>	Excavation – Embankment	Mass Ordinate	-518	<b>-518</b>	1169	$(-518 + 1169) = \mathbf{651}$	2451	$(651 + 2451) = \mathbf{3102}$	-1822	$(3102 + -1822) = \mathbf{1280}$
Excavation – Embankment	Mass Ordinate												
-518	<b>-518</b>												
1169	$(-518 + 1169) = \mathbf{651}$												
2451	$(651 + 2451) = \mathbf{3102}$												
-1822	$(3102 + -1822) = \mathbf{1280}$												

# Grading Summary

Grading Summaries are structured to be read in a logical left to right format. Nearly all projects will contain some unique features and must be dealt with on a case-by-case basis. However, the general format (headings, column titles, and layout of the columns) should remain the same. If a specific column does not apply to a specific project, hide the column within the Excel spreadsheet to avoid confusion. Uniformity of the general format will aid in comprehension.

The Grading Summary shows the earthwork volumes in the plans: prism excavation and embankment volumes, added excavation and embankment volumes, and volume of material unavailable for fill. Shown below is a typical layout for the Grading Summary (example shown is for a balanced project)

	Column D	Column E	Column F	Columns G,H,I	Columns J,K,L	Column M	Column N	Column P	Column Q	Columns S- AH	Column AI	Column AJ	Column AK or AO
<b>GRADING SUMMARY</b>													
	Roadway Excavation		Pay Item 20401-0000	Additional Excavation For info only		For info only		Embankment For info only		For info only			For Info only
<b>(a)</b> Station to Station	<b>(b)</b> Prismoidal Volume	<b>(b)</b> Approach Roads	<b>(b)</b> ROADWAY EXCAVATION	<b>(c)</b> (+) Available Material (see note 3)	<b>(d)</b> (-) Unavailable Material (see note 4)	<b>(e)</b> Shrink/Swell Factor	<b>(b)</b> Total Excavation Available For Fills	<b>(b)</b> Prismoidal Volume	<b>(b)</b> Approach Roads	<b>(f)</b> (+) Various Backfill Material Generated Onsite (see note 5)	<b>(b)</b> Total Embankment	<b>(g)</b> Excavation- Embankment	<b>(h)</b> UNCLASSIFIED BORROW (see note 6)
	BCY	BCY	CUYD	BCY	BCY		CCY	CCY	CCY	CCY	CCY	CCY	CUYD

## (a) Station Ranges

The number of station breaks shown within the Grading Summary will vary with the project. A good rule of thumb is to show each Plan and Profile Sheet on a separate row. This will coincide with the named boundaries drawn.

## (b) Prism Excavation and Embankment

These columns represent the roadway prism excavation and embankment volumes calculated by ORD.

## (c) Available Material

This column represents all the additional excavation material that is available for embankment. This may include:

- Structure excavation (walls)
- Excavation from roadway obliteration
- Subexcavation

## (d) Unavailable Material

This column represents all the additional excavation material that is unavailable for embankment. This may include:

- Pavement removal in cuts
- Topsoil stripping in cuts
- Disposal of subexcavation material

## (e) Shrink/Swell factor

This column represents the shrink swell factors to adjust quantities from the bank (BCY (BCM)) state to the compacted (CCY (CCM)) state.

**(f) Various Backfill Material Generated Onsite**

This column represents all the embankment material that is anticipated to be generated from onsite material. This may include:

- Wall Backfill
- Foundation Fill
- Select Wall Backfill
- Rock
- Granular Rock Backdrain
- Structural Backfill
- Backfill Material
- Granular Backfill
- Backfill for Pavement Removal under Fills
- Topsoil Replacement under Fills
- Aggregate Base
- Riprap
- Special Rock Embankment
- Embankment for Roadway Obliteration
- Subexcavation
- Topping or Select Topping

**(g) Excavation – Embankment**

This column represents the volume of the surplus or shortage of material.

**(h) Additional Pay Item**

This column varies depending on the project type. See Table 4 for information on selecting appropriate pay items.

**Notes**

To facilitate communication regarding Grading Summaries, the following notes should typically be used at the bottom of the table:

1. Quantities based on prismatic (surface to surface) volumes.
2. Conserve (*fill in project specific information*) inches of topsoil in cut and fill slope areas.
3. Available material includes (*fill in project specific information*). See Miscellaneous Summaries.
4. Unavailable material includes (*fill in project specific information*). See Miscellaneous Summaries.
5. Various backfill material generated on site includes (*fill in project specific information*).
6. Waste quantity calculated using volumes adjusted for shrink/swell. The average shrink/swell factor shown is computed by taking an average of recommended values over the specified range. Refer to the Geotech Report for recommended shrink/swell factors.

Or

Unclassified borrow quantity calculated using volumes adjusted for shrink/swell. An assumed value of 0.9 was used for calculations. The contractor is responsible for determining the shrink/swell on the borrow material. ")

7. The quantities shown herein are approximations. Payment will be made for the actual quantities of work performed.
8. BCY = Bank cubic yard - one cubic yard of material as it lies in the natural state.  
CCY = Compacted cubic yard - one cubic yard of material after it has been compacted to specification density.

The addition of other notes that reference geotechnical and pavement investigations, materials studies, or assumptions made, should also be used as appropriate.

**Table 4: Selection of Earthwork Pay Items**

Type of Project	Pay Items	Remarks
Balanced Project	<ul style="list-style-type: none"> <li>▪ 20401-0000 Roadway Excavation</li> </ul>	<ul style="list-style-type: none"> <li>▪ Do not include a pay item for construction of embankments</li> <li>▪ Typically include a waste or borrow quantity for information only.</li> </ul>
Waste Project	<ul style="list-style-type: none"> <li>▪ 20401-0000 Roadway Excavation</li> <li>▪ 20441-0000 Waste</li> </ul>	<ul style="list-style-type: none"> <li>▪ Include a waste pay item if there is a large volume excavation or a large percentage of the excavation will be wasted. Discuss with the CFT.</li> </ul>
Borrow Project	<ul style="list-style-type: none"> <li>▪ 20420-0000 Embankment Construction</li> </ul>	<ul style="list-style-type: none"> <li>▪ Borrow projects have several inherent drawbacks, including:               <ol style="list-style-type: none"> <li>1. During the design phase, roadway excavation and borrow pit shrink/swell factors are sometimes estimated without the benefit of a materials investigation. This leads to uncertainty in the final amount of borrow (based on pit measurements) that will be needed to complete the project.</li> <li>2. When a borrow pay item is used, borrow is generally measured by determining the volume of material removed from the borrow source (this would be a bank cubic meter measurement, not a compacted cubic meter measurement). Payment of the borrow based on pit cross sections places the risk of shrink/swell changes from those estimated above on the Government. This is true whether the source is a Government-designated source or a contractor-selected source.</li> </ol> </li> <li>▪ By using Pay Item 20420-0000, Embankment construction, (instead of a combination of Pay Item 20401-0000, Roadway excavation, and Pay Item 20441-0000, Unclassified borrow) the contractor is paid on a slope stake basis (embankment in its final position). This places the risk of shrink/swell factor changes at the chosen borrow source on the contractor. When borrow constitutes a significant amount of the earthwork to be performed, and particularly when the selection of the borrow source is up to the contractor, it is recommended that an embankment construction pay item be used. Coordinate with the CFT during the selection of pay items for borrow projects.</li> <li>▪ Generally, Pay Item 20401-0000, Roadway excavation and Pay Item 20420-0000, Embankment construction, should not be used together in the same contract.</li> </ul>

# Earthwork Representation Diagrams

The following diagrams represent the volumes of material within the cross section. They should be included in the plan set in the B sheet section. The CADD file with all diagrams can be found at [Earthwork Diagrams \(FP 14 version\)](#).

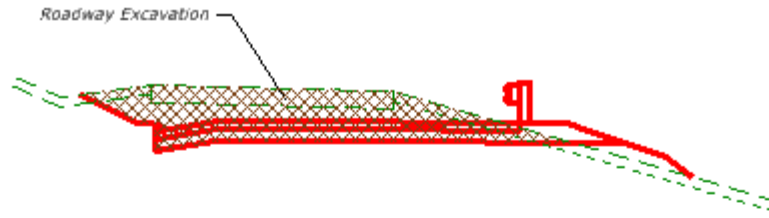

**ROADWAY EXCAVATION**

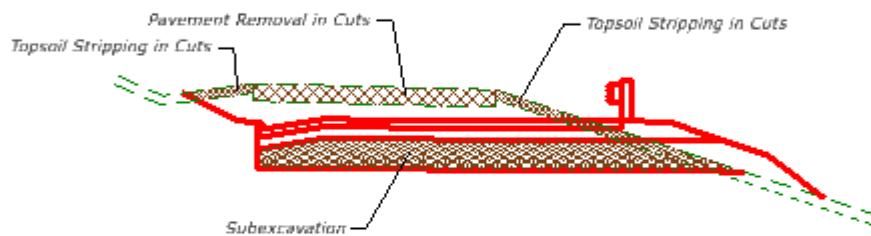

**ADJUSTMENTS TO ROADWAY EXCAVATION**

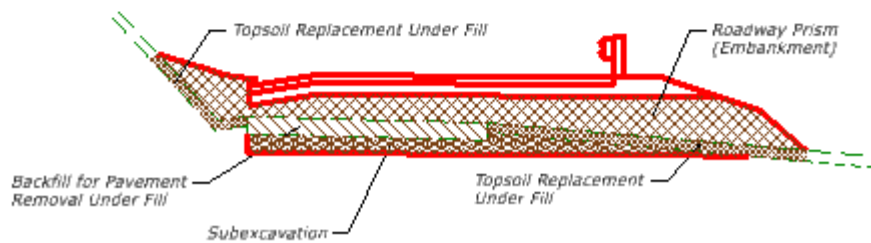

**ROADWAY EMBANKMENT**

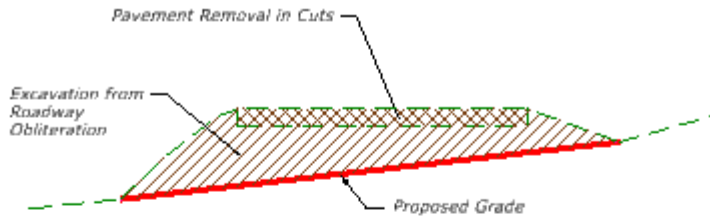

**ROADWAY OBLITERATION (EXCAVATION)**

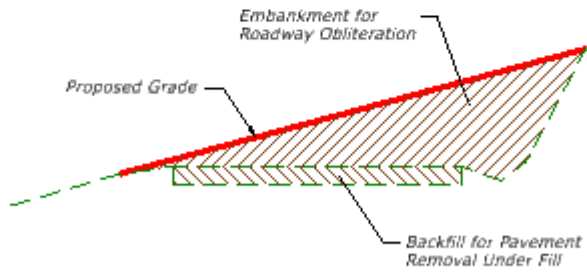

**ROADWAY OBLITERATION (EMBANKMENT)**

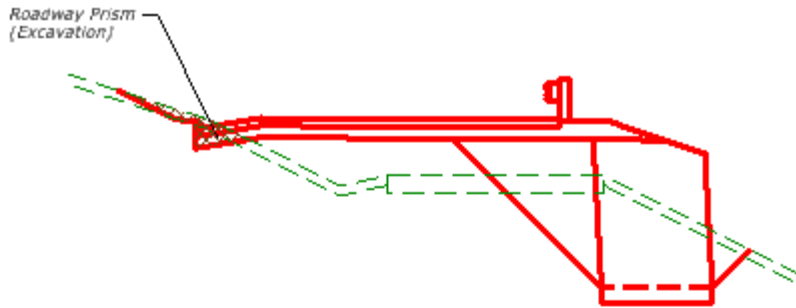

**ROADWAY EXCAVATION**  
MSE WALL

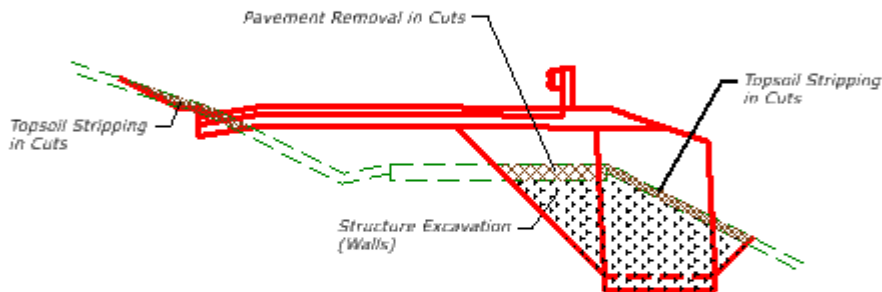

**ADJUSTMENTS TO ROADWAY EXCAVATION**  
MSE WALL

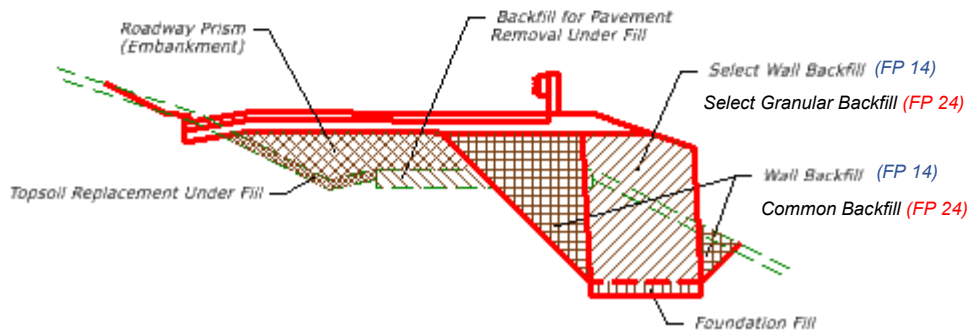

**ROADWAY EMBANKMENT**  
MSE WALL

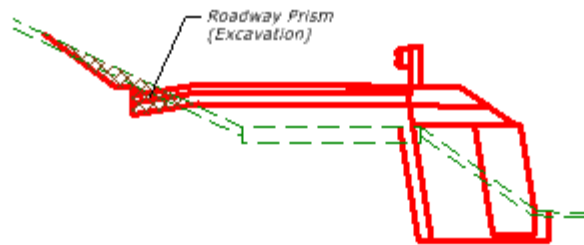

**ROADWAY EXCAVATION**  
**GABION FACED MSE**

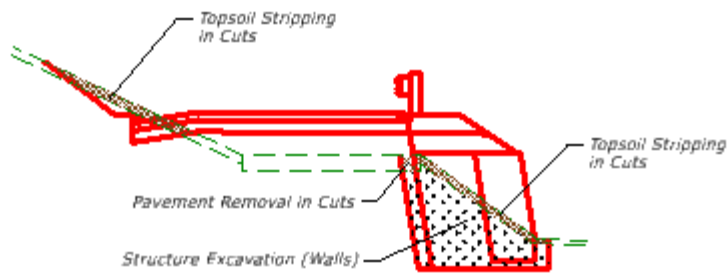

**ADJUSTMENTS TO ROADWAY EXCAVATION**  
**GABION FACED MSE WALL**

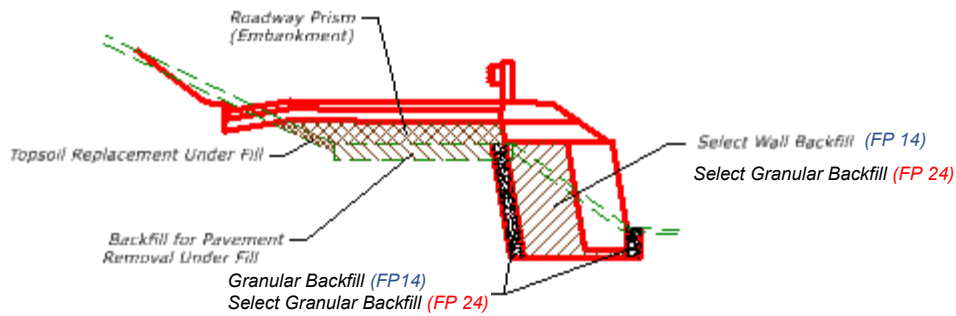

**ROADWAY EMBANKMENT**  
**GABION FACED MSE**

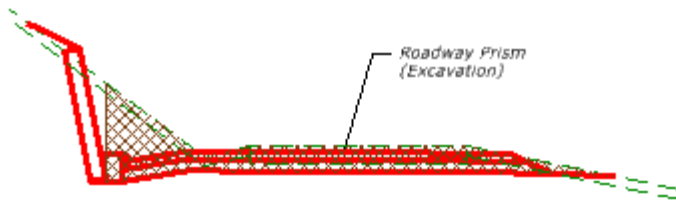

**ROADWAY EXCAVATION**  
SOIL NAIL WALL

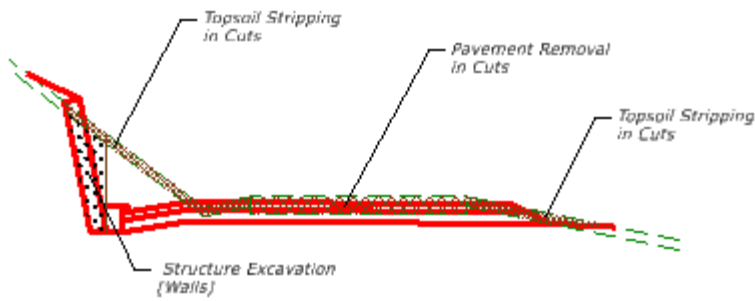

**ADJUSTMENTS TO ROADWAY EXCAVATION**  
SOIL NAIL WALL

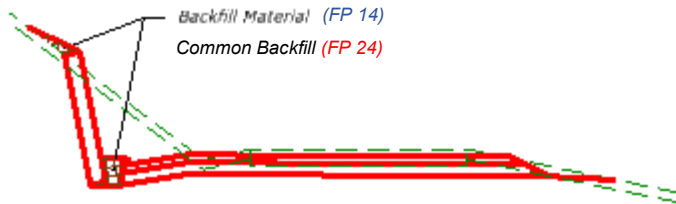

**ROADWAY EMBANKMENT**  
SOIL NAIL WALL

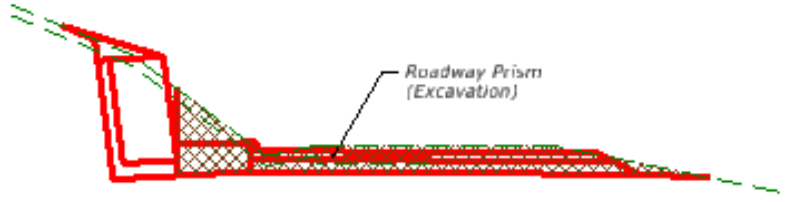

**ROADWAY EXCAVATION  
ROCKERY**



**ADJUSTMENTS TO ROADWAY EXCAVATION  
ROCKERY**



**ROADWAY EMBANKMENT  
ROCKERY**

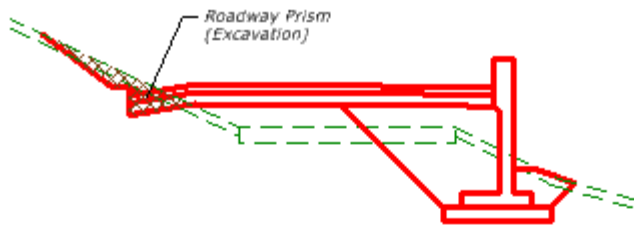

**ROADWAY EXCAVATION  
REINFORCED CONCRETE WALL  
WITH PARAPET**

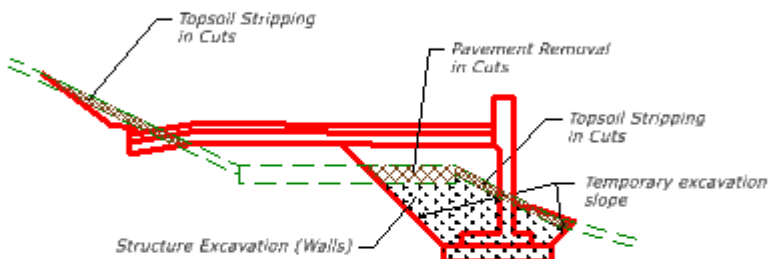

**ADJUSTMENTS TO ROADWAY EXCAVATION  
REINFORCED CONCRETE WALL  
WITH PARAPET**

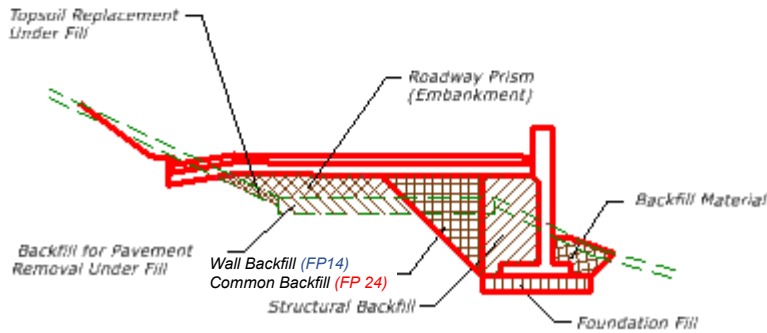

**ROADWAY EMBANKMENT  
REINFORCED CONCRETE WALL  
WITH PARAPET**

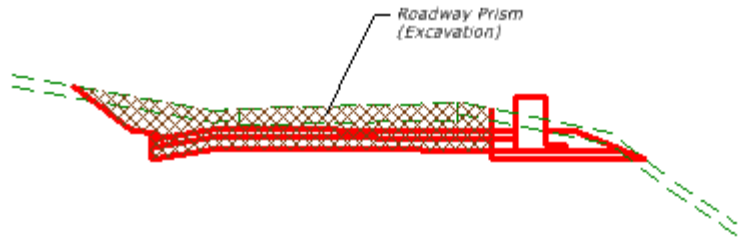

**ROADWAY EXCAVATION  
GUARDWALL**

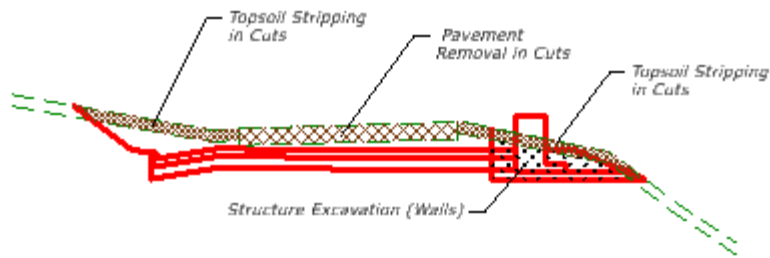

**ADJUSTMENTS TO ROADWAY EXCAVATION  
GUARDWALL**

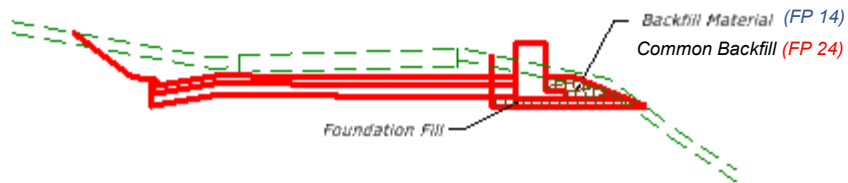

**ROADWAY EMBANKMENT  
GUARDWALL**

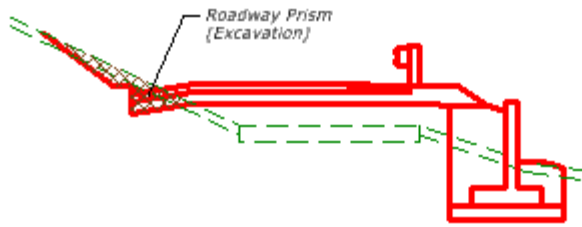

**ROADWAY EXCAVATION**  
**CONCRETE FILL WALL**

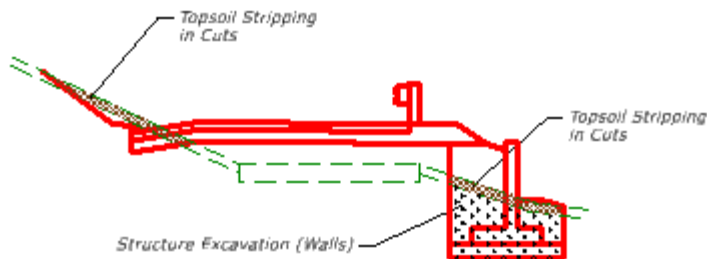

**ADJUSTMENTS TO ROADWAY EXCAVATION**  
**CONCRETE FILL WALL**

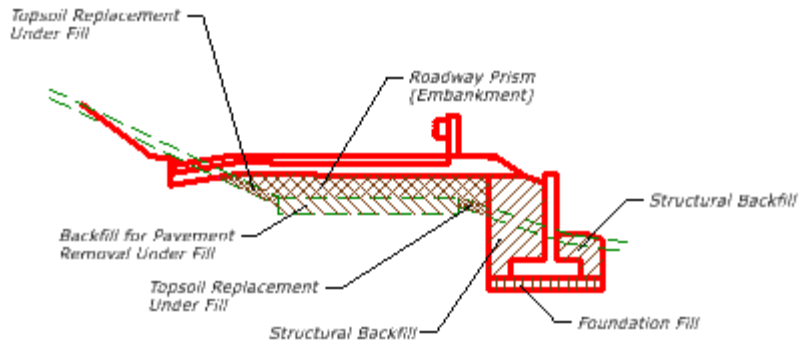

**ROADWAY EMBANKMENT**  
**CONCRETE FILL WALL**

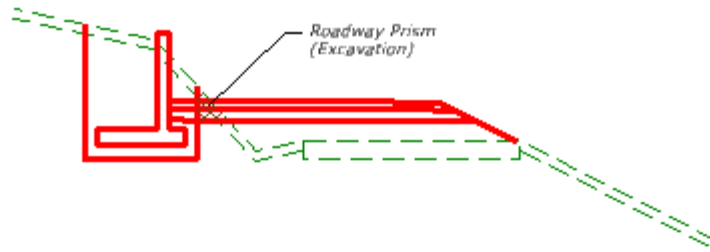

**ROADWAY EXCAVATION**  
CONCRETE CUT WALL

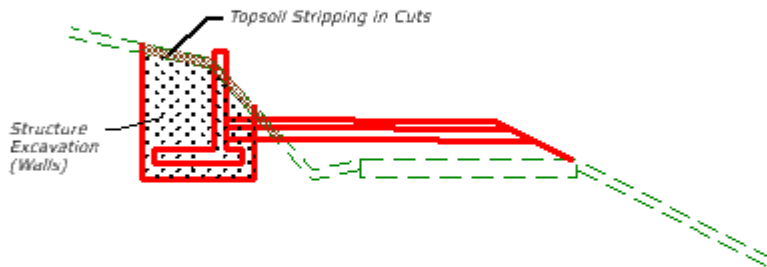

**ADJUSTMENTS TO ROADWAY EXCAVATION**  
CONCRETE CUT WALL

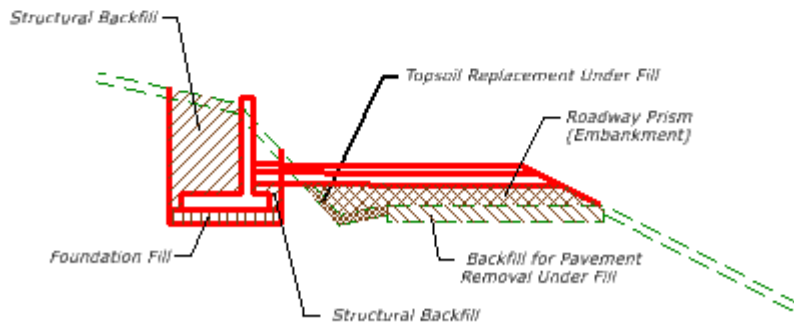

**ROADWAY EMBANKMENT**  
CONCRETE CUT WALL

## Mass Haul Diagram

**Note:** Not all projects with earthwork require a mass haul diagram. Please consult with the Project Manager and Highway Design Manager **before** including a Mass Haul Diagram in the plans.

Haul can significantly influence the cost of performing contract-related earthwork. Contractors must estimate the total amount of haul to be performed, the equipment to perform the haul and the estimated rate of haul (productivity) as part of the bid price. In the event the work changes because of Government error or a differing site condition, equitable adjustments in the price are determined (in part) by comparing the total haul anticipated from the design earthwork with the total haul required because of the change.

Productivity (rate of haul) is of critical importance in estimating haul costs. To estimate the required haul, the contractor must know where the gross material movements occur. A relatively well-detailed Mass Haul Diagram will provide sufficient information for the contractor to estimate total haul. The Mass Haul Diagram should depict a visual representation of the cut and fill material on the project, as well as indicate the cumulative balance (excess or deficit) of material available to construct the project to subgrade at given locations on the project. The diagram should be detailed enough to show all the peaks and valleys associated with the movement of the material; a simple line diagram showing only a few points along the project is not acceptable.

Much like quantities shown for roadway obliteration in realigned sections of roadway, quantities of material obtained from borrow sources should not be included in the Mass Haul Diagram. By not showing borrow, the contractor can evaluate the on-site material and consider the most cost-effective manner of constructing the project by considering existing material placement, haul, scheduling concerns, grading limitations, borrow source location, etc. The contractor may, for example, choose to move the existing material in a manner inconsistent with normal movements to reduce borrow haul, provide for culvert pipe, or wall placement, to work wet materials in the order and at the time most conducive to deal with them, or for other reasons. If borrow materials or roadway obliteration quantities associated with realignments are shown in the Mass Haul Diagram, the shape of the diagram is altered, thus obscuring the evaluation of what the on-site project dirt can do.

## Final Thoughts

There are a multitude of situations that can occur when trying to accurately represent project-specific earthwork. Care must be taken to ensure that earthwork is estimated correctly.

The general layout of the Grading Summary (major headings, pay item row, column location within the summary and column headings) and notes are important. When specific conditions result in deviations from the general format, an attempt should be made to preserve as much of the standard template as possible.

Including volumes in the Mass Haul Diagram that do not accurately reflect the true project haul conditions can lead to a misrepresentation of earthwork and claims during construction.

There are several questions designers must consider each time to prepare a Grading Summary and Mass Haul Diagram to make sure all items of earthwork are accounted for:

1. Does the Grading Summary approximate, as closely as possible, the generic Grading Summary format?
2. Do the Grading Summary and Mass Haul Diagram accurately identify the factors that are important to successfully bid the earthwork? For example:

- Are materials that will not be available for embankment operations appropriately subtracted?
  - Would the project be best served by including appropriate pay items for waste, embankment, borrow, etc?
  - Are the Grading Summary and Mass Haul Diagram accurately derived from the earthwork run and hand calculations necessary for retaining walls?
  - Do the shrink/swell factors match those presented in the Geotech report? Was sufficient investigation performed to estimate the shrink/swell factors, especially in borrow sites if they are Government-identified?
  - Are design assumptions identified and the proper notes used at the bottom of the Grading Summary?
3. Are the Grading Summary and Mass Haul Diagram complete and easily understood?
    - Are column headings clear and labeled correctly?
    - Are all pay items and pay units clearly identified?
  4. Are representative cross sections included in the plans?
  5. Do the SCRs adequately describe expectations that are not clear in the Grading Summary and Mass Haul Diagram (such as disposal of unsuitable material, potential waste sites, etc)?