

## Notes to the Designer

Updated June 2024

### 3R Typical Section Sheets - Superelevation Correction

#### General Information

-

- All graphics and text will be in the design model. Only use the sheet model for printing and adding applicable guardrail as a reference. There is a sheet model for each type (Super at CL and Super at Edge); Reference guardrail using the appropriate saved view from the design model to the appropriate sheet model.
- Update sheet title by renaming the model.
- Length of Project table is intergrated into the sheet. Double click on the cell to edit.
- **3R Superelevation Correction Template Drawings.** Refer to the 3R+ Matrix to ensure this is the appropriate template to use for your application. Use these template drawings for spot locations where superelevation corrections are proposed and the lane and shoulder widths remain the same as existing. This includes any major slope corrections that would result in significant pavement surface elevation changes.
- **Road Inventory Program Milepost data.** The NPS uses the Road Inventory Program (RIP) as part of their asset management program. Include the RIP milepost data in the 'Length of Project' table for NPS projects only. To find this information, use Pathweb (<https://pathweb.pathwayservices.com/rip/>) or ask Planning and Programming. Delete the last column in the 'Length of Project' table for all non-NPS projects (e.g. USFS, USFWS, IRR, etc.).

#### Applicable SCRs

- SCR's used can vary based on the project and pay items used. Ensure that SCR's provided are consistent with the pay items provided in the contract. Coordinate with the Pavements Engineer to select and edit the appropriate SCR for the project. Include in Section 152 what information is being provided to the Contractor. Recommend using 304 SCR if the project requires regrading the subgrade. Refer to the designer's notes in each SCR for common items needing input and editing.

#### Typical Pay Items Used

- The pay items used for 3R projects in Sections 152, 302, 304, 305, 306, 401, 402, 403 can vary per project. Refer to the CFLHD Engineer's Estimate Manual for recommended pay items. Coordinate with the Pavements Engineer to determine the most appropriate pay items for the structural section. When the existing pavement structure needs to be removed and reused in order to regrade the subgrade, use Section 304 pay items along with earthwork pay items. When the existing pavement structure can be pulverized and reused in place, use 304 pay items; likely no earthwork pay items will be needed in this case. Evaluate the need to include a seperate 302 pay item for imported aggregate as well as 304 pay items based on volumes required to construct proposed typical section.
- Subexcavation may be included. Roadway excavation or embankment may be included.

#### Other Recommendations for 3R Superelevation Correction

- Cross sections are typically provided.
- Staking Reports are typically provided. Provide blue top reports if no earthwork is required. Provide both subgrade template report in addition to blue top report if earthwork is required.
- Plan/Plan Sheets or Plan/Profile sheets typically provided. Provide superelevation diagram.

#### Updates

- **April 2021**
  - Template sheet created
- **Opctober 2022**
  - References to 308 pay items and SCR removed
- **April 2023**
  - Updated safety edge detail; updated border; updated to international seed file
- **June 2024**
  - Updated for FP24

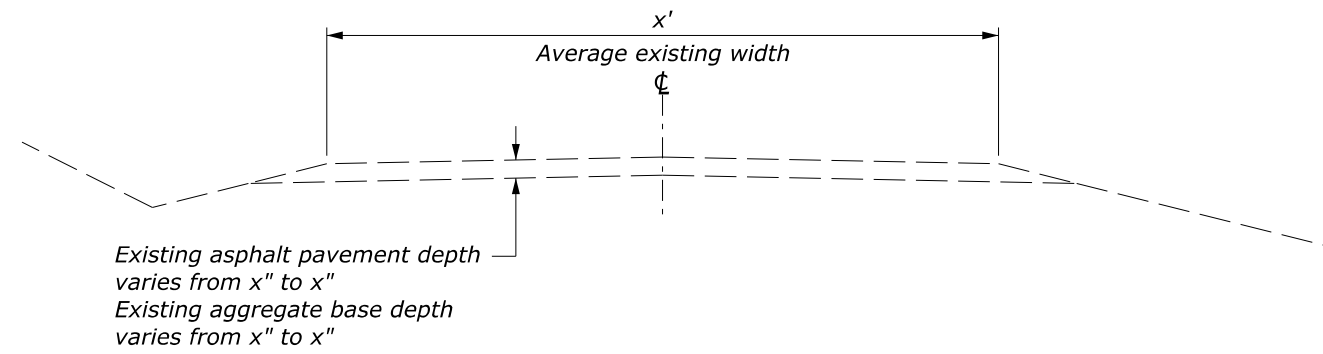

**EXISTING TYPICAL SECTION**  
 <<>> to <<>>

**Note:**

1. Superelevation correction areas have been identified in the plans.
2. See cross sections for cut and fill slope ratios.
3. Remove the pulverized material to construct the subgrade as needed. Reuse the pulverized material in the structural section. See section 304.

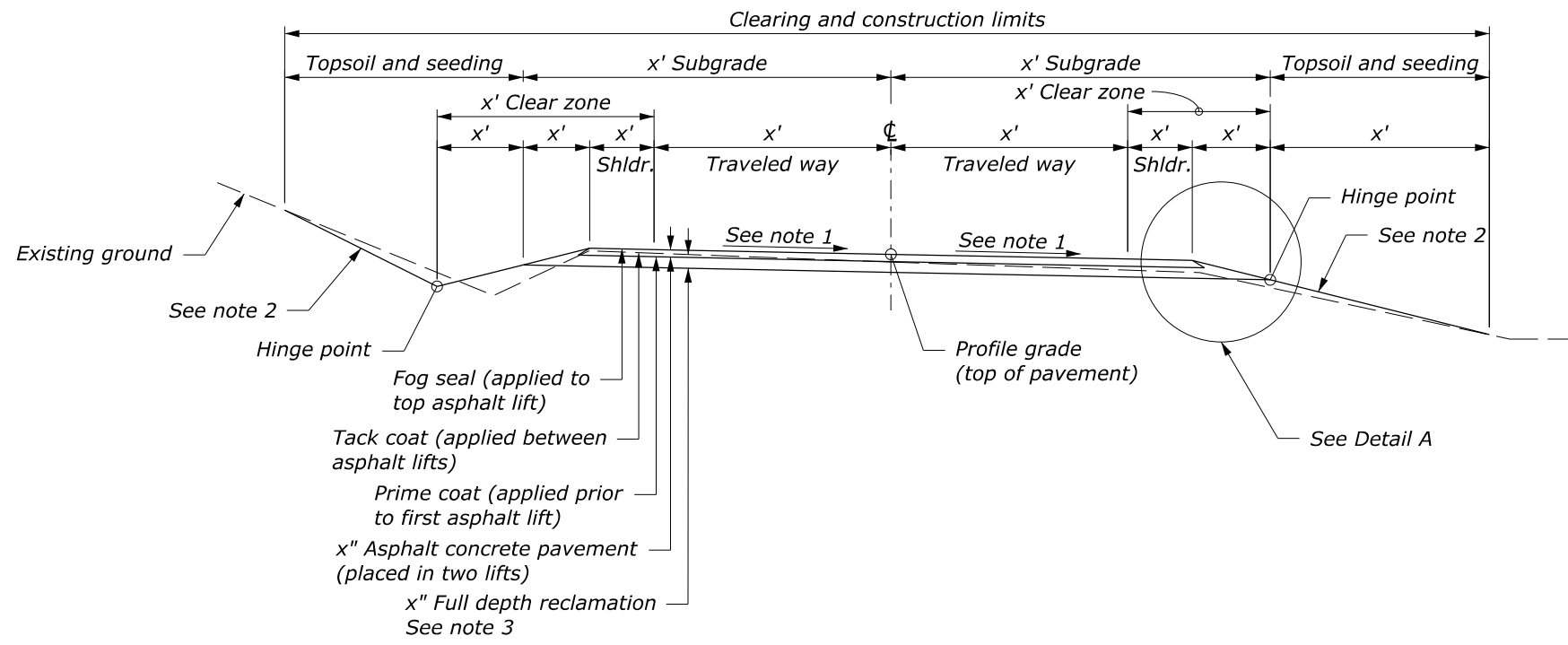

**TYPICAL SECTION**  
 <<>> to <<>>

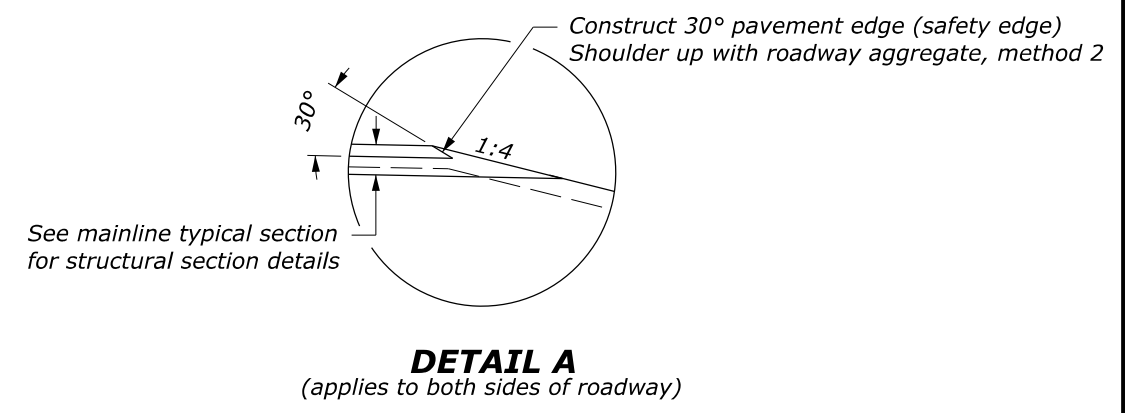

**DETAIL A**  
 (applies to both sides of roadway)

<b>LENGTH OF PROJECT</b>			
Station to Station	Roadway (ft)	Bridge (ft)	Road Inventory Program Milepost Data (Cycle #)*
??+?? to ??+??			
??+?? to ??+??			
??+?? to ??+??			
<b>TOTALS (ft)</b>			
<b>TOTALS (mi)</b>			

\*Road Inventory Program data shown for information only

**TYPICAL SECTION MAINLINE - SUPER AT CENTERLINE**

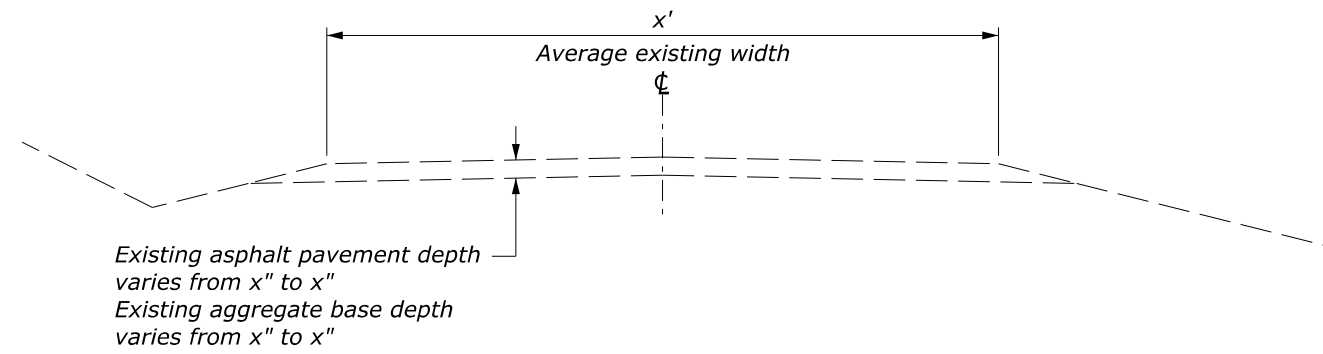

**EXISTING TYPICAL SECTION**  
 <<>> to <<>>

**Note:**

1. Superelevation correction areas have been identified on the plans.
2. Construct a 1:4 or flatter slope. Steepen the foreslope as necessary, but not steeper than 1:2 to stay on the existing bench.

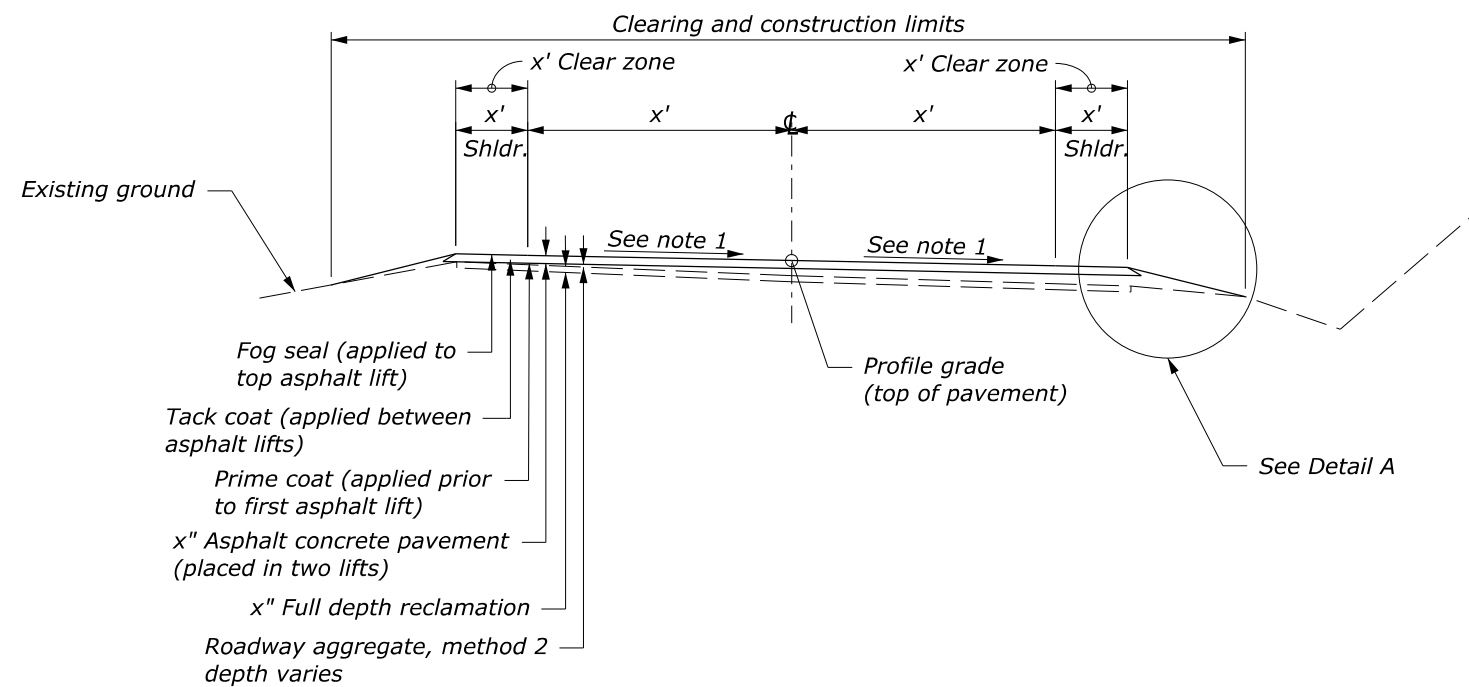

**TYPICAL SECTION**  
 <<>> to <<>>

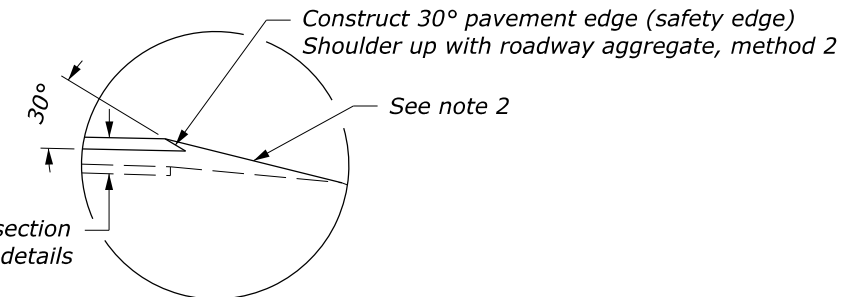

See mainline typical section for structural section details

**DETAIL A**  
 (applies to both sides of roadway)

<b>LENGTH OF PROJECT</b>			
Station to Station	Roadway (ft)	Bridge (ft)	Road Inventory Program Milepost Data (Cycle #)*
??+?? to ??+??			
??+?? to ??+??			
??+?? to ??+??			
<b>TOTALS (ft)</b>			
<b>TOTALS (mi)</b>			

\*Road Inventory Program data shown for information only

**TYPICAL SECTION MAINLINE - SUPER AT EDGE**

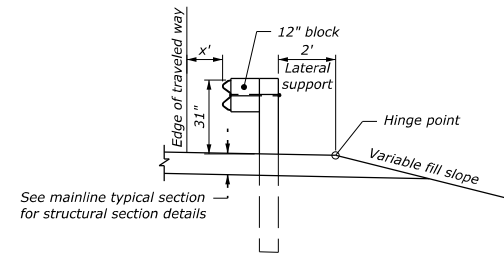

See mainline typical section for structural section details

**MGS GUARDRAIL  
TYPICAL SECTION**

## 12" Block & 2' Lateral Support

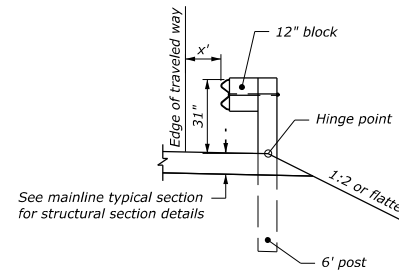

See mainline typical section for structural section details

**MGS GUARDRAIL  
TYPICAL SECTION**

## 12" Block & No Lateral Support

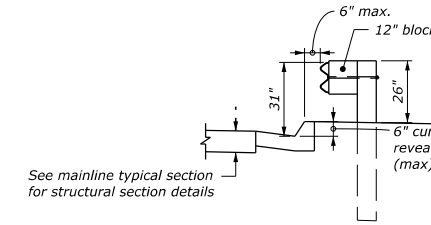

See mainline typical section for structural section details

**MGS GUARDRAIL  
TYPICAL SECTION**

## 12" Block & Curb and Gutter

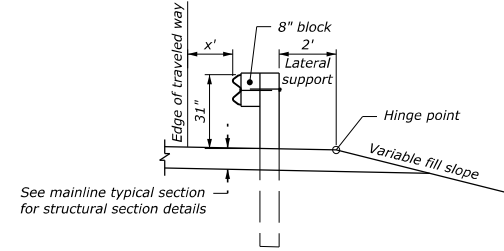

See mainline typical section for structural section details

**MGS GUARDRAIL  
TYPICAL SECTION**

## 8" Block & 2' Lateral Support

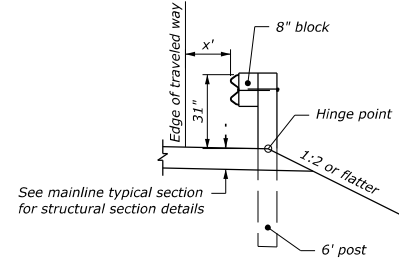

See mainline typical section for structural section details

**MGS GUARDRAIL  
TYPICAL SECTION**

## 8" Block & No Lateral Support

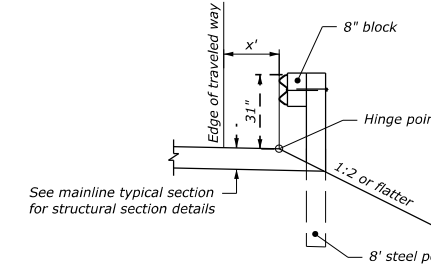

See mainline typical section for structural section details

**MGS GUARDRAIL  
TYPICAL SECTION**

## 8" Block & Face of GR at Hinge Point

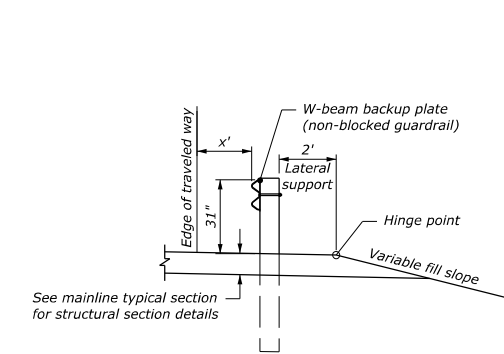

See mainline typical section for structural section details

**MGS GUARDRAIL  
TYPICAL SECTION**

## No Block & 2' Lateral Support

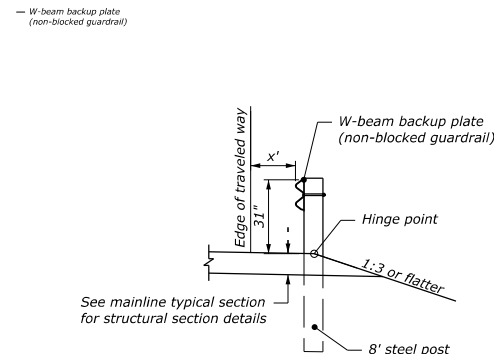

See mainline typical section for structural section details

**MGS GUARDRAIL  
TYPICAL SECTION**

## No Block & No Lateral Support